

Rural Builder

Serving The Construction Trade Since 1967

www.constructionmagnet.com



SOURCE BOOK 13

Inspiration, Innovations and
Cutting-Edge Ideas to Inspire
Your Next Construction Project

AMERICAN MADE

CONSISTENCY.
DEPENDABILITY.
PREDICTABILITY.

MADE

BUILT ON TRUST

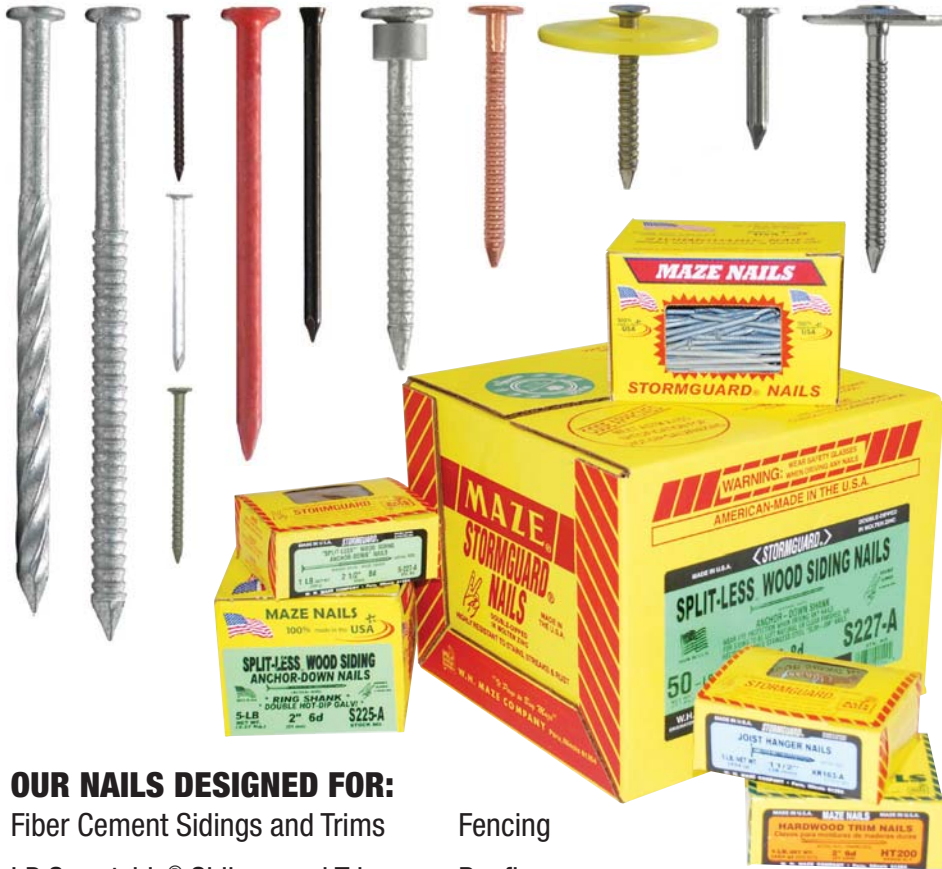

OUR NAILS DESIGNED FOR:

- | | |
|---------------------------------|---|
| Fiber Cement Sidings and Trims | Fencing |
| LP Smartside® Sidings and Trims | Roofing |
| Cedar and Redwood Sidings | Joist Hangers |
| Cedar Shakes and Shingles | Post Frame Building |
| Gutter, Soffit and Fascia | Pressure Treated Lumber |
| Log Home and Landscape Timbers | Pre-Finished Siding Nails (100 Colors+) |

BUILT ON TRUST & VALUE

- 100% American Made
- Double Hot-Dipped Galvanized, Stainless Steel, Copper and Aluminum
- Ring and Spiral Shanks hold tight in high wind
- Available in Coils, Sticks and Hand Drive
- Roofing nails are Miami-Dade County Approved
- Quick and accurate shipping from our Illinois manufacturing facility

STABILITY
seven generations since 1848

INTEGRITY
shaped by strong principles

QUALITY
premium products

SERVICE
impeccable standards



NAIL IT **ONCE**. NAIL IT **RIGHT**.®

1.800.435.5949
mazenails.com

editor's note

BY KAREN KNAPSTEIN

Parade of homes, sheds, garages ...

THIS YEAR'S SOURCE BOOK IS just a bit different than those you've seen in the past. You'll still see the diverse projects you've come to expect; herein you will find sheds, garages, post-frame homes, a winery, a distillery ... you'll even find a remarkable home restoration, in which a historic house was disassembled, moved, reassembled and painstakingly restored. I've grossly oversimplified the project; learn more about it beginning on page 20.

While I may have my favorite buildings in this issue, I'm not going to share my opinions or preferences with you. I don't want to take the chance of influencing *your* opinion one way or the other. You see, in the next edition of Rural Builder, you'll find a ballot that you can use to vote for your favorite Source Book project. Fill out your ballot and send it back to us. (You can also vote via email; email your favorite to karen@shieldwallmedia.com.) Once we've tallied all the votes, we'll publish the results and you can see if your tastes align with your peers. We'll also reach out to the builders of the top projects and, if those builders are willing to participate, we will profile their businesses right here in Rural Builder. Look for more details in the September edition.

What's different: In this edition, you'll find a select group of Product Profiles. These are just some of the tried and true products that low-rise builders like you use. (Of course, you'll find many, many more product profiles in the October Buyers' Guide edition.)

Looking ahead to the September edition, we'll be diving in to METALCON 2021! It feels wonderful getting back out to attend trade shows. There's just no substitute for meeting face-to-face with manufacturers and builders. The folks over at METALCON have been planning quite the affair. In addition to the exhibitor profiles (including complete contact information), we'll be sharing the new and special events and features that you'll find at the Tampa Convention Center October 6-8. We'll also offer some family-friendly suggestions so you can make the most of your October visit to the Sunshine State.

Until next time — be well.

Karen

BUILDING CONNECTIONS



East Coast Fasteners produces durable, long lasting fasteners for all combinations of building materials.

- Quick Ship Program
- Extended Warranties
- Colors to match any rollformed steel
- High quality products for any application

East Coast Fasteners...**Building Connections** for the construction industry.



800.558.5895 • www.plyco.com

The FASTEST, SHARPEST, CLEANEST Drilling Fasteners Available!!

Ply-Lo Extended • Ply-Lo Extreme • Ply-Lo Driller • Ply-Fast • Metalfast
Stainless Steel • Ply-Lo Low Profile • Flashers • Closures • Wood Deck



SOURCE BOOK 13



projects

- 6 CONCRETE COMMODITY STORAGE**
by Sukup Manufacturing Co.
- 8 WINERY**
by Wick Buildings
- 10 RESIDENTIAL RE-SKIN**
by Graber Post Buildings
- 12 MULTI-PURPOSE GARAGE**
by Cover's Construction
- 14 DISTILLERY**
by Metallic Building Systems
- 15 RESIDENCE & WORKSHOP**
by CHIEF Buildings
- 19 RESIDENCE**
by Kebony North America
- 20 HISTORIC HOME RESTORATION**
by CertainTeed
- 23 CLIMATE-CONTROLLED SHOP**
by Popple River Construction
- 24 BARN WITH LEAN-TOS**
by Reed's Metals
- 26 MULTI-PURPOSE SHOP**
by Frontier Builders
- 28 GARAGE**
by Cedar Valley Post-Frame
- 30 HOBBY SHOP**
by Perma-Column
- 32 HOME & SHOP**
by MPB Builders
- 34 MULTI-PURPOSE SHOP**
by Metal Depots
- 36 AUCTION GALLERY**
by SmartBuild Systems
- 38 HOBBY SHOP**
by Greiner Buildings
- 40 ORCHARD BUILDINGS**
by S-5!

Rural Builder®

Managing Editor

Karen Knapstein
karen@shieldwallmedia.com
715-513-6767

Contributing Editors

Sharon Thatcher, Toni Rahn,
Tracy Schubert

Circulation/Subscriptions

Barb Prill
barb@shieldwallmedia.com
920-471-4846

Digital Product and Data Engineer

For help with online Classified Ads
& the Business Directory contact:
Steve Duberstein:
steve@shieldwallmedia.com

Publisher

Gary Reichert
gary@shieldwallmedia.com
715-252-6360

Executive/Advertising Assistant

Kathy Budsberg
kathy@shieldwallmedia.com

Sales Assistant

Kathy Welk
kathyw@shieldwallmedia.com

Graphic Designers

Tom Nelsen
Kevin Ulrich

Rural Builder (ISSN: 0888-3025) Volume 55
Number 5 is published monthly, except January,
April, June and November, by Shield Wall Media
LLC, 150 Depot St., Iola, WI 54945. Periodical
postage paid at Iola, WI, and at additional
mailing offices. Canadian Agreement Number:
40665675. POSTMASTER: Send address
changes to Rural Builder, Barb Prill, PO BOX
255, Iola, WI 54945. Copyright 2021 Shield
Wall Media LLC. Rural Builder and its logo are
registered trademarks. Other names and logos
referred to or displayed in editorial or advertising
content may be trademarked or copyright. Rural
Builder assumes no responsibility for unsolicited
materials sent to it. Publisher and advertisers
are not liable for typographical errors that may
appear in prices or descriptions in advertisements.
Mailed free to rural contractors and their suppliers
throughout North America. Others may subscribe:
\$29.98 for 1 year, \$55.98 for 2 years, and \$79.98
for 3 years in the U.S.; \$39.98 for 1 year, \$74.98 for
2 years in Canada.



32

41 HOME & STORAGE SHED
by American Building Components

42 MULTI-PURPOSE SHOP
by Hixwood Metal

44 BANK
by Petersen | PAC-CLAD

45 CORPORATE HEADQUARTERS
by McElroy Metal

46 CLASSIC CAR WORKSHOP
by Metl-Span

47 WORKSHOP
by Worldwide Steel Buildings

48 MACHINERY STORAGE
by Walters Buildings

DEPARTMENTS

Editor's Note.....	3
Business Connections.....	16
Product Profiles.....	50
Advertising Index.....	57
Classified Ads.....	57

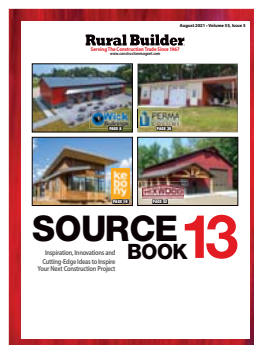

ON THE COVER:

Clockwise from
top left: Winery by
Wick Buildings;
Hobby Shop by
Perma-Column;
Multi-Purpose
Shop by Hixwood
Metal; Residence
by Kebony North
America.



e-mail the editor at
karen@shieldwallmedia.com

Check our website, the Construction Magazine Network:

www.constructionmagnet.com

CONCRETE COMMODITY STORAGE



SUKUP MANUFACTURING CO.

www.sukup.com

LOCATION:

Charles City, Iowa

SIZE:

86,250 sq. ft., 2 buildings

CONTRACTORS:

Croell Redi-Mix

BUILDING PRODUCT:

Pre-engineered Steel Building,
Sukup Manufacturing Co.

ROOF AND WALL PANELS:

Roof: Sukup SA-16, 2" Architectural Standing Seam Roof System, 24 ga., Bright Red
Wall: Sukup MSP, 26 ga. Shadow Rib through-fastened wall system, Saddle Tan

This is a new building on an existing Croell Redi-Mix location. On this location they have an already existing operational concrete mixing plant and shop building. The new building is a concrete commodity storage building. The storage area alone is 80,000 square feet and can house 87,000 tons of cement.





Sukup Manufacturing Co. Headquarters - Sheffield, Iowa



Sydenstricker Nobbe Partners Implement - Chillicothe, MO



Ames Municipal Hangar - Ames, Iowa



West Fork Recreation Center - Sheffield, Iowa



Patterson Farms Grain Center - Fillmore, Missouri



Sukup
STEEL BUILDINGS

With an expanding diversity of designs and uses, whether you need an agricultural building to house livestock, materials, or large machinery, or you are looking for an industrial or commercial structure, you can have it with a Sukup Steel Building.

WHY PURCHASE A SUKUP STEEL BUILDING?

- Clear Span up to 200'
- Purlins, Girts, and Eave Struts are pre-punched to ensure proper fit & faster installation and are galvanized for long life.
- Factory Welded Clips mean fewer pieces & bolts, lowering construction costs.
- Customizable to meet your specific needs.



WINERY



WICK BUILDINGS

www.wickbuildings.com

LOCATION:

Jacksonville, Illinois

SIZE:

40' x 120' x 17'
interior clear height

BUILDING MANUFACTURER:

Wick Buildings

BUILDER:

Kevin Miller, Custom Structures, Inc.

WALL PANEL:

Wick Steel, 29 ga., G-90, Red

WAINSCOT & ROOF PANEL:

Wick Steel, 29 ga., G-90,
Charcoal Gray

DOORS:

Service doors: Plyco Corp.
Overhead doors: Haas Door

CUPOLAS:

MWI Components (2) 36" louvered
vented cupolas; (1) 48" window
cupola

INSULATION:

Ceiling: Blown fiberglass
Walls: Fiberglass blanket

VENTILATION:

24" vented overhangs
Flo-Thru Ridge Vent

FASTENERS:

SFS Woodgrip color-matched screws
Maze Nails

OTHER:

Concrete-attached columns
Decorative bale doors
4' canopy over overhead doors
Gable foyer entry
Perforated steel ceiling panel for
sound abatement
Tyvek Infiltration Barrier on walls

The Waters Edge Winery & Bistro was built in Jacksonville, Illinois as a destination location for both quality wine and events. The owners needed a space that could accommodate both production of wine and guests in a warm and friendly setting, without the space feeling like a large warehouse. Kevin Miller of Custom Structures, Inc. [www.custom-structures-inc.com], an experienced Wick Builder with more than 25 years of experience, took the customer's needs and was able to translate them into two buildings that can serve a number of uses. The main building is the winery and bistro with indoor/outdoor seating. A slightly smaller building, the "Wine Barn," is set up as an event center and frequently hosts weddings.

PLYCO

MWI
COMPONENTS



Wick Buildings

Commercial ■ Residential ■ Agricultural
Retail ■ Suburban ■ Equestrian

WickBUILDINGS.COM 800-356-9682

RESIDENTIAL 'RE-SKIN'



GRABER POST BUILDINGS

www.graberpost.com

LOCATION:

Southern Indiana

SIZE:

2,228 sq. ft.

BUILDER:

Graber Post Buildings

ROOF:

Graber Post 26 ga. 16" Standing Seam AZ55 Galvalume

WALLS:

Graber Post 26 ga. 10" Board & Batten, White

FASTENERS:

ST Fastening Systems



Constructed in 2000, this single story ranch style home was beginning to show some wear. The original asphalt shingles and vinyl siding were well past their service life, which gave the owners the opportunity to upgrade to more durable materials. Graber Post Buildings had the solution with their new 10" coverage 26 ga. metal Board and Batten siding and their 26 ga. 16" coverage Standing Seam metal roofing.





ADVANCED BUILDING ENVELOPE TECHNOLOGY

|| DUAL SOLUTION ENGINEERING
TWO HEADS DESIGNED TO MATCH YOUR ROOF SYSTEM

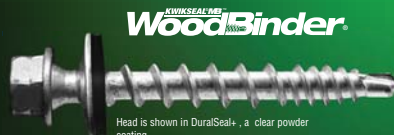

Proprietary* Technologies Create Multiple Layers of Protection

- * Powderful or Clear Coat Duraseal+ Unique Powder Coat Protects Against Fading and Rust Environmentally Friendly No VOC's
- * ZXL Zinc Aluminum Molded Head System

- ZAMAC Head Acts as a FIREWALL Against RED RUST
- Zinc Plating and Chromate Sealer Enhanced Corrosion Resistance
- 40 Year Warranty
- ZXL Head is Guaranteed Against RED RUST

Choose the Protection You Require

	POWERFUL	ZAMAC Head	Zinc Chromate	40 YEAR WARRANTY
ZXL™ Best	✓	✓	✓	✓
KWIKSEAL™ MB Better	✓		✓	

GREATER ENERGY EFFICIENCY

Specialty Fasteners



Accessories



ST Fastening systems
Built Strong Through Innovation

Call Today
800-352-4864
www.stfasteningsystems.com

©2021 ST Fastening Systems A Division of the Hillman Group

MULTI-PURPOSE GARAGE



COVER'S CONSTRUCTION LLC

www.coversconstruction.com

LOCATION:
Granger, Iowa

SIZE:
56' x 72'

ARCHITECT:
Midwest Manufacturing

CONTRACTORS:
Cover's Construction LLC,
Dallas Center, Iowa

BUILDING SYSTEM:
Midwest Manufacturing

ROOF AND WALL PANELS:
Roof: Prosnap Standing Seam
Wall: SmartSiding

INSULATION:
Spray foam

WINDOWS:
Jeld-Wen Windows

Our customer wanted a modern farmhouse/barn style to use as a garage for their car collection as well as a place to entertain friends and family. They wanted an open concept with lots of natural light.



MAXIMIZE EFFICIENCY & MINIMIZE WASTE WITH THE CONVENIENCE OF AUTOMATION.

SWI's Reliable, Fast, & Easy-To-Operate Systems Ramp Up Any Sheet Metal Project.

Marxman Plus

The Marxman Plus Automatic Slitter provides all the capability and reliability of traditional Marxman machines with the added efficiency of **8 pairs of auto setting slitter blades**. It also includes a user-friendly interface that provides for **automatic part nesting**, waste minimization, and integration with a wide range of business software via ShopLink. Plus, with **speeds of up to 150FPM**, you'll be amazed to see just how efficient your operation can be!



Marxman Plus
Automatic Slitter

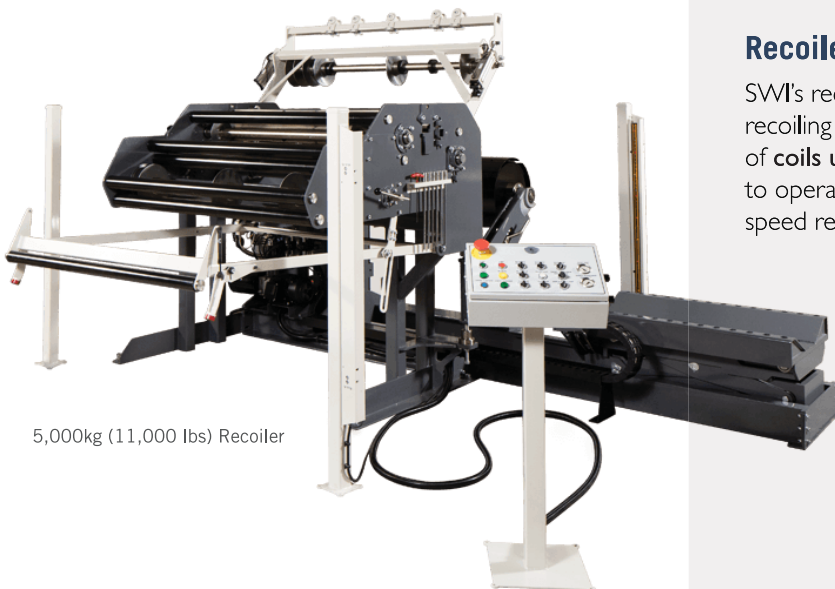

5,000kg (11,000 lbs) Recoiler

Recoiler/Rewinding Coil Threading System

SWI's recoiling system provides an effective, low-cost recoiling solution for occasional or frequent recoiling of coils up to 5,000kg (11,000 lbs). Our recoiler is easy to operate, with quick, ergonomic coil insertion, automatic speed regulation, and simple controls. Not only is the recoiler simple to use, but it also gets the job done with speeds up to 150 FPM, easy-to-set guides, and pneumatic slitter cut off.

When coupled with SWI's Marxman slitters, the recoiler becomes an efficient tool for trim manufacturers.



For Full Catalog or Quote:

(770) 766-0880 • info@swimachinery.com • SWImachinery.com

DISTILLERY



METALLIC BUILDING SYSTEMS

www.metallic.com

LOCATION:

North Charleston, South Carolina

SIZE: 19,000 sq. ft.

BUILDING SYSTEM:

Metallic Building Systems

BUILDER:

Trident Construction

ROOF AND WALL PANELS:

Roof: MBS SuperLok®, Galvalume Plus®

Wall: MBS PBC Panel, Charcoal Gray

WINDOWS:

YKK, Model YHS-50TU, 2 1/2' x 5'

OVERHEAD DOORS:

Acme Doors

FANS: Swifter

After years of growth, Firefly Spirits, Charleston's oldest working distillery – best known for producing the world's first sweet tea flavored vodka – had outgrown their original distillery and tasting room.

Now a nationally recognized brand with more than 25 spirits distributed in all 50 U.S. states, Firefly founders Jim Irvin and Scott Newitt decided to move their operation to North Charleston and sought a builder who could replicate the small, quaint feel of their original distillery on a larger scale using stronger materials.

"When Firefly first came to us, their architect had drawn up plans for a conventionally built structure," said Todd Bulwinkle, vice president at Trident Construction. "But we knew a metal building would be faster, more cost efficient and, with Charleston situated in a hurricane-prone area, steel would provide the strength needed to endure high-storm conditions."

"We used 12 different metal building structures and put them together to create an old horse-barn look," said sales rep Jay Murphy. "And to top it all off, the grand entrance looks identical to the original distillery, 30 miles away in Wadmalaw Island."

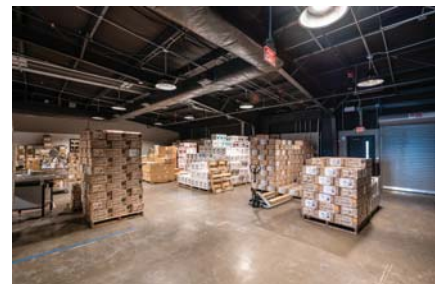

RESIDENCE & WORKSHOP



CHIEF BUILDINGS

www.chiefbuildings.com

LOCATION:

Merino, Colorado

SIZE:

11,200 sq. ft.

ARCHITECT:

Buildings By Design

CONTRACTORS:

Sierra Steel

BUILDING SYSTEM:

Chief Buildings

ROOF AND WALL PANELS:

Roof: Chief STC

Wall: Chief AP

INSULATION:

High "R" liner system

OTHER:

Wrap-around porch roof panels:

Chief CS

Cottonwood Creek Farms, a family owned non-GMO poultry, pork and beef producer utilizing sustainable farming techniques. Project is a 2-story residential building with attached garage and work shop. Wrap-around porch is wood framed and embellished with gabled projections, hips & valleys, and includes panels and trim to match the main structure.



Trusted. Tested. True.®

Chief started manufacturing metal buildings in 1966. Fifty five years later, we are still a family-owned company focused on building lasting relationships. We accomplish that by producing quality products and by providing unparalleled personal attention to meeting our customer's needs.

- Manufacturing - Industrial



- Vehicle Maint. - Dealerships



- Agricultural - Personal Use



- EMT / Rescue - Fire / Police



- Religious - Community



www.chiefbuildings.com



Celebrating **75** YEARS
1946 UNION 2021
"Your Roof. For Life."
On Time and Complete!

www.unioncorrugating.com
1-888-685-7663

**Metal Roofing, Metal Panels,
and Metal Building Solutions**

Since 1946, Union Corrugating has been an industry leader serving the residential, commercial, and agricultural roofing and siding markets.



UNIVERSAL TUBE & ROLLFORM EQUIPMENT **UNIVERSAL CONTROLS GROUP**

- Metal Panel Rollformers
- New Controls & Drives
- Coil Handling Machines
- Reconditioning Services

IN STOCK **IN STOCK** **IN STOCK**

1-419-872-2364 utubeonline.com



3RD ANNUAL
Construction Rollforming Show
OCTOBER 26-27, 2022
New Orleans Ernest N. Morial Convention Center

FOR MORE INFORMATION CONTACT GARY REICHERT:
gary@shieldwallmedia.com • 715-252-6360



2021
GARAGE • SHED • CARPORT
BUILDER SHOW
CENTURY CENTER • SOUTH BEND, INDIANA
NOVEMBER 4-5, 2021
FOR INFORMATION CONTACT GARY 715-252-6360

DID YOU KNOW?

It costs less to buy a Business Card ad than it does to have cards printed.
We even give your "cards" to more than 40,000 potential customers.



**Actual Card Size
(3.5" x 2")**

FOR MORE INFO CONTACT GARY REICHERT:
gary@shieldwallmedia.com 715-252-6360

Manufacturer of Roll Forming Equipment



Phone: (330) 674-4003
 Fax: (330) 674-4035
 Email: acu-form@safecommail.com • Website: acuformequipment.com

Golden Rule
 FASTENERS
QUALITY PRODUCTS
COMPETITIVE PRICES
& MOST ORDERS SHIP THE SAME DAY

- Screws • Closures • Ridge Vent
- Pipe Flashings • Butyl Tape • And much more!

Ph: (334) 283-4030 - FAX (334) 283-4032

DMI = BUILDING INVESTMENT PROTECTION

Let DMI complete your building project with Code Approved & Warrantied:

HWH & PANCAKE FASTENERS • ANCHORS • PIPE FLASHINGS
 REFLECTIVE INSULATION • POLYCARBONATE PANELS
 SOLID & VENTED FOAM CLOSURES

www.directmetalsinc.com 855-800-8878

PREMIUM QUALITY
ROLLFORMING MACHINERY

ASC MACHINE TOOLS, INC. MADE IN USA SINCE 1949

PANEL ROLLFORMER
 TRIM ROLLFORMER
 SLITTING LINES
 PURLIN LINES
 DECKING LINES
 CHANNEL LINES

WWW.ASCMT.COM TEL: (509) 534-6600

Factory Direct Garage Doors for Sheds

The Anniston The Meridian

KEVMAR
 Arthur, IL

sales@kevmar.net Phone 217-543-2828

AMES
WATERPROOFING COATINGS & SEALANTS
 COMMERCIAL | RESIDENTIAL | FACILITIES

ELASTO BARRIER
 MAXIMUM FLEX
 BLUE MAX

WATER CLEANING
 GREEN PRODUCT
 LOW VOC
 LOW ODOR

MADE IN THE U.S.A. CALL ABOUT BULK ORDERING
www.amesresearch.com | 888-345-0809

JOHNSON BROS.
 Roll Forming Co.
www.johnsonrollforming.com

info@johnsonrollforming.com

5744 McDermott Drive, Berkeley, IL 60163-1102
 Phone: 708-449-7050 FAX: 708-449-0042

LEVI'S
 BUILDING COMPONENTS

Buy all your metal roofing accessories in one place

Call for free samples!
 (877) 897-7020
www.levisbuildingcomponents.com

CONTRACTORS NEEDED!

Ready to increase your profits in 2021?

We help contractors start their own commercial roof restoration business, or add it to their existing business.

Call now to receive a free inspection kit valued at \$250.

855-835-8885



THE MOST AFFORDABLE, ALL-IN-ONE SOLUTION FOR IN-GROUND POST DECAY AND UPLIFT RESTRAINT

P (610) 377-3270
www.planetsaverind.com



Proudly Serving Customers Since 1998!



BUY DIRECT AND SAVE!

We are the manufacturer specializing in:

- ▶ Metal Roofing
- ▶ Post Frame & Tube Buildings
- ▶ Pre-Engineered Metal Buildings & Storage Solutions
- ▶ Components and Accessories



- ▶ 45 Year SMP Paint Warranty
- ▶ Over 20 Colors Available
- ▶ Order Today, Pick-Up Today
- ▶ On In-stock Roofing & Supplies
- ▶ Delivery within 72 Hours on Most Products



Call Today 1-800-581-4645

PROTECTION YOU CAN COUNT ON!



SSG Classic Snow Stoppers
Made of all stainless steel products.

RMG Premium Snow Stopper
Made out of 14-gauge stainless steel.

Contact us and we can give you all the details!
717-598-0312

WE WELCOME WHOLESALERS!



A Lifetime of Quality and Relationships



3814 E. US 30 Warsaw, IN. 46580 • (574) 267-2813

For over 40 years Stockade has supplied our Dealers the Best Quality of Materials and Dealer Services!

Stockade Buildings
"Building for the future"
systems@stockadebuildingsinc.com
800-548-6765

Commercial • Equestrian • Suburban • Industrial

THE BRADBURY GROUP

Your Single Source Equipment Provider
bradburygroup.com
+1.620.345.6394
bradbury@bradburygroup.com

UNITED STEEL SUPPLY

STEEL PRODUCTS FOR THE METAL ROOFING & METAL BUILDING INDUSTRY

Understanding Superior Service

512-263-0954 • unitedsteelsupply.com

RESIDENCE



KEBONY NORTH AMERICA

www.kebony.us

LOCATION:

Animas Valley, New Mexico

BUILDING SIZE:

3,590 sq. ft. (livable)

ARCHITECT:

Jim Rothwell

ROOF PANELS:

Metal Sales Magna-Loc flat pan standing seam

ROOF UNDERLAYMENT:

Metal Sales ms-HT SBS modified bitumen self adhesive

SIDING:

Kebony Clear Tongue & Groove Cladding

DOORS:

Interior: TruStile, painted

Exterior: Kolbe Vistaluxe, aluminum clad, painted wood interior

WINDOWS:

Kolbe Vistaluxe, aluminum clad, painted wood interior

MILLWORK:

Delta Millworks

VENTILATION:

Multi-zone Hydronic in-floor heat w/ insta-hot boiler and sidearm storage

INSULATION:

Cellulose blown in: R-49 roof; R-22 walls; R-38 floors over crawl space.
Dox XPS rigid polystyrene under slabs on grade, R-10

PHOTOGRAPHY:

Marona Photography

OTHER:

Rain screen system: Zip-sheathing and Core-a-vent flow management system

A custom modern home sitting atop a bluff overlooking New Mexico's 85-mile-long Animas Valley recently completed construction, according to architect Jim Rothwell, who designed the project.

"After taking the time to understand and appreciate the power of the views, the clients decided on a strong yet simple form for the massing," Rothwell said. "Which was essentially a direct response to the views, all coupled with a site-driven expression of natural materials."

Kebony was specifically chosen for its natural wood texture and rich brown color that will naturally develop a silver-grey patina, minimizing maintenance without further use of finish treatment.

"The idea was strength in form, calm in approach, and natural in finish," Rothwell said.

HISTORIC HOME RESTORATION



CERTAINTEED

www.certainteed.com

LOCATION:
Cape May, New Jersey

SIZE:
3,559 sq. ft.

BUILDER:
Paul Burgin Builders

SUPPLIER:
Universal Supply, Cape May

SIDING:
CertainTeed: Cedar Impressions Staggered Perfection (Snow), Cedar Impressions Scallop, Half Cove and Octagon (Snow), Cedar Impressions T5 Sawmill (Snow)

INTERIOR PAINT:
Benjamin Moore Chantilly Lace

For decades, the “Avalon House” was a fixture of the coastal community of Avalon, New Jersey. The impressive, three-story Queen Anne-style home—built in 1895 by Avalon’s first tax assessor George W. Kates to serve as his summer cottage—currently sits on a plot 20 miles away in neighboring town of Cape May. In 2017 the property was sold to a developer who planned to raze the historic property to make way for a two-story, single family home with a swimming pool. After a long and unsuccessful effort to preserve the home in the city of Avalon, the Scharnikow family that had owned the home from the mid-1950s to the mid-1990s utilized a quitclaim deed to buy back the home for \$1. The one stipulation was that the home would be physically moved to another location.

The Avalon House was disassembled and moved north to a muddy storage yard in Egg Harbor Township, where the home sat in pieces for more than a year while the Scharnikow family obtained the permits to physically transport the home

40 miles down the Jersey Shore to a plot they secured in Cape May. The home had survived two lightning strikes, numerous nor’easters, and the Great Atlantic Storm of March 1962, but sitting in the mud without a foundation for more than a year took its toll on the home’s flooring, exterior, and structural elements. By the time the home reached its final destination to Cape May to local fanfare, much of the home was in need of a serious facelift.

The Scharnikow family wanted to retain original circa 1895 appearance of the house while making it comfortable and functional for 21st-century living. According to homeowner Adrienne Scharnikow, blending the old and new required a lot of work and attention to detail. Modern improvements included an addition doubling the home’s square footage from 1,820 to 3,559 square feet, converting the layout from a 3 bed/2 bath to a 6 bed/5 bath, bringing all of the plumbing and electrical up to code, and adding closet space.

At the same time, Scharnikow



LELAND Specialty Fasteners

Master Grippers® Grippers MDP®

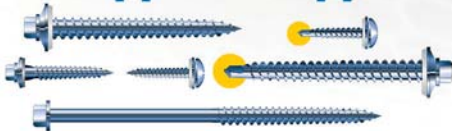

For the post frame building industry
 MDP metal panel to wood or light steel girt or purlin.

Master Tappers®



Roof panel to panel - roof sheet to structural A - AB - B points available, type F, type 23, type 1, BP & more. Lengths to 8" available.



AVAILABLE: A325 STRUCTURAL BOLTS

A325 Heavy Hex Structural Bolts assembled and unassembled in our convenient 1/4 Keg Pails. Manufactured in 1/2", 5/8" & 3/4" diameters in lengths from 1-1/4" to 6".

Master Drillers®



Attach metal panel to metal girt or purlin, stitching & structural applications. Lengths to 8" available.

Powder Coating



Our Powder Coated paint system allows us to match your painted steel supplier's warranty.



1.800.263.3393
 www.lelandindustries.com



Made in Canada

071719_12

maintained or restored many of the original Victorian features, including much of the original wood flooring; classic light fixtures; black exterior scrollwork; decorative exterior corbels; interior molding with bullseye plinth blocks; a front porch with a pebble dash finish made of beach stones, shells and sea glass; an original claw foot tub; and the home's third story viewing tower (with two feet added for a better view of the coastline). Certain delicate items like original stained glass windows were removed from the house and re-installed after the move to Cape May.

One area that needed attention was the home's original mixed cedar shake siding. Much of it was soft or rotted. The city of Cape May takes historic preservation seriously and required siding materials that could replicate the appearance of a late Victorian era home. CertainTeed Impres-



sions polymer shingles were selected for their era-appropriate look and maintenance-free demeanor.

The Cape May Historic District is included in the U.S. National Register of Historic Places, so the town has high standards when it comes to restoring homes. The variety of Cedar Impressions shingle shapes allowed Burgin and his team to accurately replicate the Queen Anne style of the Avalon House with modern materials less susceptible to coastal moisture. Burgin utilized a combination staggered shingles on the front and older sides of the house; scallop, octagon, and half-cove shingles on the front, gable, and tower; and sawmill shingles on the majority of the addition, which was built onto the back of the home. In all, 54 squares of polymer siding were used to restore the Avalon House's original, off-white façade.

Bolt pattern accommodates your choice of center guide

1/2" steel top plate and shield for rugged reliability

Precast concrete column with rebar reinforcement

3x STRONGER THAN STANDARD CONCRETE

Threaded rod and footer plate simplify height adjustment

PRECAST CENTER POSTS FOR SLIDING DOORS

Eliminate wood stub failure

Installation is fast and easy!

- Auger minimum 12" hole to 44" depth
- Attach adjustment rod and footer plate to the Center Post
- Place Center Post into hole
- With top plate being level, check for desired location
- Rotate Center Post clockwise until desired height is reached
- Double check top plate for level and correct location
- Back fill with concrete mix covering the bottom 6" of Center Post
- Finish backfilling hole after concrete has set up
- Backfill in 12" lifts and tamp each lift
- Attach center guide bracket to top plate with 3/8 bolts
- Avoid driving on Center Post until concrete has completely cured

MIDWEST PERMA-COLUMN

BEST PRODUCTS

Patent Pending

800-798-5562 www.midwestpermacolumn.com

The Affordable Rollforming Equipment Manufacturer

Metal Rollforming Systems designs and manufactures reliable and affordable rollforming equipment and accessories, making us a leader in rollforming equipment manufacturing. Our unsurpassed technical support is unlike any other in the industry, we work until the job is done. Our customer's success is our success. For more information, please contact us at 509.822.8123 or visit us online.

- Single & Double Deck Rollformers
- Trim Rollformers
- *NEW* Patriot Rollforming Line
- Coil Reels

- Precision Cut Slitting Lines
- Sheet Stackers
- Coil Upenders
- Ridge-Cap Press

2020 METAL ROOFING TOP 10 PRODUCT

509.822.2123 www.mrsrollform.com

CLIMATE-CONTROLLED SHOP



POPLER RIVER CONSTRUCTION LLP

www.poppleriverconstruction.com

LOCATION:

Colby, Wisconsin

SIZE:

60' x 100' x 16' w/ 8' x 16' + 16' x 8'
wrap-around porch

DESIGNER & BUILDER:

Popple River Construction LLP

ROOF AND WALL PANELS:

Roof & Walls: Everlast Roofing Inc.
Lynx panel, 28 ga., Charcoal

Wainscot: Everlast Roofing Inc., 28
ga. Lynx panel, Clay

Trim: Everlast Roofing Inc., 28 ga.,
Clay

WINDOWS:

Windgate vinyl slider windows in Tan

ENTRY DOORS:

30/68 Plyco Model 20, Hickory Moss

OVERHEAD DOORS:

Ideal Door w/ Ultra Grain Walnut
finish

INSULATION:

Spray foam walls, cellulose attic

VENTILATION:

Vented eave soffits in Clay and
ridgecap closures

FASTENERS:

ST Fastening Systems

OTHER:

Stained cedar porch posts

The customer needed a climate controlled shop for his trucking business and for additional personal storage space. The interior is finished with white metal liner panel. Woodgrain finish steel overhead doors complement the stained cedar porch posts. Stamped concrete was used for the porch floor. In-floor radiant heat keeps the building at a comfortable temperature during cold WI winters and also quickly dries up any snow melt from trucks that are parked inside overnight.



PLYCO

BARN WITH LEAN-TOS



REED'S METALS

www.reedsmetals.com

LOCATION:

Florida

SIZE:

Main Pole Barn: 24' x 40' x 10"

Lean Tos: 10' x 40' x 8'

ROOF AND WALL PANELS:

Main Pole Barn: 4:12 pitch

Roof: PBR Metal Roofing Panel, 26 ga., Galvalume, 25-yr. warranty

Wall: PBR Metal Siding Panel, 26 ga., AkzoNobel Coating, Barn Red, 45-yr. warranty

LEAN TO:

2:12 Pitch

Roof: PBR Metal Roofing Panel, 26 ga., Galvalume, 25-yr. warranty

MAIN POLE BARN PURLINS:

Red Oxide painted 6" ZEE purlins

TRUSSES:

Red Oxide painted trusses



ORDER YOUR CUSTOM POLE BARN & METAL BUILDINGS DIRECTLY FROM US ... WE ARE THE MANUFACTURER!

ORDER TODAY,
PICK UP TODAY
ON MOST IN-STOCK
ROOFING
AND SUPPLIES!

FREE QUOTES
& FINANCING
AVAILABLE



Delivery within
72 hours on most
products



Buy
Direct
and Save!



Industry leading
45-year paint
warranty



Over
20 colors
in-stock



www.reedsmetals.com • 800-581-4645

Metal Roofing • Post Frame Buildings
Pre-Engineered Metal Buildings • Storage Solutions
Buy Direct and Save!



FLORIDA
BUILDING
CODE 2010
APPROVED
FL #12725-R1



METAL ROOFING
ALLIANCE
MEMBER



MULTI-PURPOSE SHOP



FRONTIER BUILDERS LLC

www.buildwithfrontier.com

LOCATION:

Bedford County, Pennsylvania

SIZE:

50' x 88' x 16' w/ 16' x 88' x 8' second floor; 8' x 22' x 8' hipped porch

ARCHITECT / DESIGNER:

Frontier Builders LLC

CONTRACTORS:

Frontier Builders LLC

ROOF AND WALL PANELS:

Roof: Fabral Grandrib 3 Plus with CondenStop; **Walls & Interior Liner Panel:** Fabral Grandrib 3

DOORS:

Overhead: CHI Overhead Door, (3) 14' x 14', Model #5283
Walk: (3) ThermaTru, 36"
Attic Access: AJ Manufacturing, 2' x 4'

WINDOWS:

(7) PlyGem ProSeries 3' x 6',
(4) PlyGem ProSeries 3' x 4'

VENTILATION

Marco Industries, LP2, vented ridge closures; 16" vented overhangs

CUPOLAS:

(2) 30" w/ fixed glass windows,
(1) 48" w/ fixed glass windows & weathervane

INSULATION

Ceiling: R-38 dry blown cellulose w/ 6 MIL vapor barrier
Walls: R-19 kraft faced fiberglass batt; DOW Gaps & Cracks spray foam

SNOW RETENTION

Snow Defender 4500

This 50' x 88' x 16' multi-use post frame project located in South Central Pennsylvania has many unique features. Designed to be a multi-use shop for excavation and racing equipment, the client also wanted to add a second floor attic space for a future living space. With over 5,800 sq. ft. of useable space, this turn-key project is a complete package.

OTHER:

Posts: RigidPly Rafters 4-ply 2"x8" GluLam posts w/ 4' "Y" bracing & 16" blocking

Headers: Quadruple 2"x12" SYP MSR Headers

Weather Barrier: Tyvek

Attic Subfloor: 3/4" AdvanTech

Shutters: Mid-America raised panel vinyl shutters

Gutters: Alcoa 6" seamless Aluminum w/ 4" downspouts

Porch Posts: Superior Plastic Products Post Sleeves



Roofing Ventilation & Accessories



The First Look into Your Building



Plyco Performance ♦ Plyco Quality

Since 1951 Plyco has created construction opportunities for contractors with a complete line of entry doors that surpass building codes and customer expectations.

Plyco's entry doors are designed for post frame and metal building applications:

Structural Performance

Plyco doors are tested to ASTM E330 for structural performance of exterior doors. Each Plyco door is engineered to specifications for a durable long lasting product

- Series 92: AAMA LC-PG40 - LW +/- DP 40 PSF (4070)
- Series 20 w/deadbolt: ASTM E330 DP +/- 60 psf (4070)
- Series 95 w/deadbolt: ASTM E330 DP +/- 75 psf (3070)



Structural Performance



Extensive Product Testing

Third party testing assures our products meet and exceed the IBC Building code standards

- Air Infiltration: ASTM-E283
- Water Penetration: ASTM-E331
- Physical Endurance: AAMA 920



Wind/Air Infiltration Tested



Water Infiltration Tested



PLYCO

800.558.5895 ♦ www.plyco.com

WINDOWS ♦ WALK DOORS ♦ RIDGE VENTS ♦ FASTENERS ♦ HORSE STALLS
SLIDE DOOR TRACK & RAIL ♦ SPECIALTY PRODUCTS ♦ PLY-FOIL ♦ CLOSURES

MULTI-PURPOSE GARAGE



CEDAR VALLEY POST-FRAME LLC

www.cedarvalleypf.com

SIZE:
30' x 48'

DESIGNER & BUILDER:
Cedar Valley Post-Frame LLC

DESIGN SOFTWARE:
SmartBuild Systems

WINDOWS:
Wincore

ENTRY DOOR:
Plyco Series 92

GARAGE DOORS:
Palmerton Garage Door

ROOF AND WALL PANELS:
Everlast II Omni 27 ga. AZM125 w/
Colorbond paint

FASTENERS:
Everlast WoodBinder Screws

VENTILATION:
MWI Components Ultra X Ridge Vent

This 30' x 48' three car features 10' x 10' overhead doors, three 5' wide dormers and a 3' front overhang. Additional features include radiant floor heating, epoxy floor, ducted split system HVAC, an explosion proof fan and 14' wide attic space. The black and charcoal exterior features bronze windows, bronze entry door and bi-directional wood grain overhead doors. We isolated the garage from the attic space by insulating and finishing the stairwell and installing an entry door at the top of the stairs. Although unfinished, the builder ran the drain plumbing for a bathroom to be installed in the attic in the future.



PLYCO

MWI
COMPONENTS



DOORS THAT WORK!

960 E Cemetery Ave, Chenoa, IL 61726
815-945-3667 • ibeamdoor.com
ibeamdoor@gmail.com



SLIDING DOORS

Heavy duty doors with minimal moving parts, maintenance free for decades of operation. 115MPH wind warranty sliding door with reputation unsurpassed to back it up. Outstanding heavy duty hardware, 6000# Ultra Glide trolleys, and EZ locking latches for ease of use for a lifetime.

INCREDIBLE SWING DOOR

Strong aluminum frame for ultimate safety and operation. No need for bulky dangerous uncontrolled hydraulic power systems, these doors run with smart servo drives that control the motion, speed, and accuracy that's unmatched to anything else on the market.

HOBBY SHOP



PERMA-COLUMN

www.permacolumn.com

LOCATION:

Auburn, Pennsylvania

SIZE:

28' x 48' x 10'

CONTRACTORS:

Original Pole Buildings, Bethel, Pennsylvania

ROOF AND WALL PANELS:

Roof: AB Martin Roofing
Wall: AB Martin Panel

INSULATION:

Fiberglass batt, R30 ceiling

VENTILATION:

Ridge cap, vented soffit

FASTENERS:

ABM Screws

SNOW GUARDS:

Snow Jacks

OTHER:

AB Martin Roofing Board-N-Batton Siding
Perma-Column precast columns



The customer requested both a hobby shop for storage plus an entertainment area which included the 28' x 12' open pavillion area. All columns including the stone wrapped pillars on outside pavillion were done with Perma-Column precast columns and 3-ply 2x6 glue lam posts to give it a "lifetime" foundation.



TREATED LUMBER MISTREATING YOU?

It is increasingly hard to find. Lumber costs have spiked 250%

Get treated better.

Perma-Column® precast columns and Sturdi-Wall® anchor brackets are the post-frame builder's solutions to the treated lumber problem. No wood in the ground. No treated lumber required.

Contact your distributor today!



permacolumn.com

Build better. Build stronger. Build to last.



HOME & SHOP



MPB BUILDERS

www.mpbuilders.com

LOCATION:
Lamartine, Wisconsin

SIZE:
50' x 56' shop; 42' x 52' living area; 8' x 52' wrap-around porch

BUILDING DESIGNER:
MPB Builders

ROOF AND WALL PANEL:
McElroy Metal

WINDOWS:
AJ Manufacturing, Harmony

WALK DOORS:
AJ Manufacturing

OVERHEAD DOOR:
CHI Overhead Doors

INSULATION:
Bay Insulation

FASTENERS:
Ideal Fasteners

This new facility was built for Ken Montsma of Lamartine, Wisconsin, who was looking for a building to act as a garage/shop and also to serve as his home.

The project includes a 50' x 56' insulated and lined shop area with 50' x 16' two story area, to house his office, restroom, laundry room, mechanical room as well as two spare bedrooms upstairs. The living quarters (42' x 52') has an open room concept with large dining and den area with large kitchen area along with a master bedroom and bathroom.

The living quarters portion has vaulted ceilings with car siding on walls and ceiling along with half log siding on exterior of walls to accent the wrap around porch (8' x 52'). "The owner is an avid hunter and he wanted a rustic cabin look that he could show off his animal mounts and be able to look out the large bay windows into the country side and enjoy the wildlife", explains project manager Doyle Pokorny. "This was a unique and fun project to be a part of."

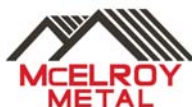



One Chance, Aim Wisely!

Hitz Halter

Quality. Performance. Lasting Value.



- ✓ Energy Efficient
- ✓ Termite Resistant
- ✓ Strong & Dependable
- ✓ 4'x24' Fan Folded For Easy Installation



Below Grade Insulation:
*A Choice
 You won't regret!*



'Hitz' your bottom line!

HitzHalter@HersheysMM.com 877-661-3030

420 Progress Drive
 Mattoon, IL 61938

MULTI-PURPOSE SHOP



METAL DEPOTS

www.metaldepots.com

LOCATION:

Zachary, Louisiana

SIZE:

Home: 7,890 sq. ft.

Shop: 75' x 60'

ROOF AND WALL PANELS:

Home Roofing: Metal Depots Slimline® snap-lock concealed fastener panels;

Roof color: Coal Black

Porch roof:

PBR Panels in Charcoal

Porch wall: PBR Panels

Installer: KLM Erectors

OVERHEAD DOORS:

Overhead Door Co.

FASTENERS:

Metal Depots

Home builders have a tendency to live in several of the homes they build. At some point, all homeowners build the home they know will be their last move. Carl Blackwell, owner of KLM Erectors in Zachary, Louisiana, expects the home he moved into in July 2020 to be his final stop. So, the plan had to include a shop behind the house that features a kitchen, gym and game room.

Blackwell started building the home and shop in early 2020. The 7,890 sq. ft. home has 6,110 sq. ft. of living space, including a porch topped by 980 sq. ft. of Slimline® snap-lock concealed fastener panels. The roofing color is Coal Black to match the asphalt shingles on the rest of the home.

For the shop, Blackwell started with the “roof only” package and worked on selecting components, including wall materials, as he went along. The roofing is PBR Panels in Charcoal, approximately 4,500 sq. ft. The PBR exposed fastener panel covers 36” and has a rib height of 1-1/4”.

“The front of the shop is brick and the left side is 75’ of PBR Panels,” Blackwell says. “The other side is divided into three equal sections, a kitchen, game room and a gym, all facing the pool.”





GOLDEN RULE FASTENERS, INC.

MOST ORDERS SHIP SAME-DAY

- ◆ ROOFING SCREWS
- ◆ DECK SCREWS
- ◆ METAL BUILDING SCREWS
- ◆ RIVETS
- ◆ BUTYL TAPE
- ◆ CAULK
- ◆ PIPE FLASHINGS FOR METAL ROOFING
- ◆ PIPE FLASHINGS FOR SHINGLE ROOFING
- ◆ RETROFIT PIPE FLASHINGS
- ◆ SOLID FOAM CLOSURE STRIPS
- ◆ VENTED CLOSURES
- ◆ RIDGE VENT MATERIAL
- ◆ NUTSETTERS AND BITS
- ◆ WOODWORKING SCREWS



Ask Us About Peel & Seal®

When you need it fast, call Golden Rule Fasteners!



Ph: (334) 283-4030 - Fax: (334) 283-4032 - Email: grfast@centurytel.net

AUCTION GALLERY



SMARTBUILD SYSTEMS

www.smartbuildsystems.com

LOCATION:

Orleans, Indiana

SIZE:

81' x 148' x 16' w/ wrap-around porch

BUILDER:

Graber Post Buildings

DESIGN SOFTWARE:

SmartBuild Systems

ROOF & WALL PANELS:

Graber Post Buildings (GPB) G-Rib, 29 ga. Coating: 40-year AkzoNobel 1050: Dark Red, Shiny Black

OVERHEAD DOOR:

CHI Overhead Doors, insulated, w/ Liftmaster opener

RAIN & SNOW HANDLING:

GPB 6" seamless gutters (color matched). GPB Snow Block

CUPOLAS:

MWI Components: (1) 4x4 w/glass, (2) 3x3 w/louvers

FASTENERS:

ST Fastening Systems

POSTS:

GPB 3-ply 2x8 laminated columns



Robinson Auctions and Services contacted Graber Post Buildings with ideas of building structure that could be the main facility for all their auction needs as well as a facility that could be rented out for other events. This building has served its purpose well for birthday parties, family reunions and gatherings, holiday parties, meetings, and even wedding receptions. Graber Post took their sketches and was able to bring them to life!





PC: Gräber Post

800.360.6467

- Arcadian Sliding Doors
- Bale Doors
- Box Girts
- Cupolas
- Door Rail
- Dutch Doors
- Foil Insulation
- Hardware/Accessories
- Horse Stalls
- Polycarbonate & PVC
- Ridg-Vents®
- Round/Square Track
- Soffit & Trim Systems
- Ultra-X, Uni-Seal®
- Uni-Vent®
- Weathervanes



HOBBY SHOP



GREINER BUILDINGS

www.greinerbuildings.com

LOCATION:

Muscatine, Iowa

SIZE:

60' x 60' x 16'

BUILDER:

Greiner Buildings

ROOF AND WALL PANELS:

Central States Panel Loc Plus,
29 ga.

DOORS:

AJ Manufacturing, 7100 Series

WINDOWS:

AJ Manufacturing, Harmony EZ Fit

FASTENERS:

Maze Nails, Atlas Screws

FOUNDATION:

Embedded Post Saver-wrapped
columns with insulated frost wall

INSULATION:

Walls: Closed cell spray foam,
R-14;
Ceiling: Cellulose, R-38

VENTILATION:

MWI Components pre-cut vented
soffit

OTHER:

Posts: Rigidply glulam with
GreenPost

Trusses: Engineered Building
Design 60' clear span

Wainscot: Versetta Stone



This custom-designed post frame residential garage is used to store classic cars, house a workshop area, and features a cozy social space for family and friends to gather. At 3,600 square feet, this spacious building is lined and insulated, climate-controlled and includes a 3/4 restroom.

The customer chose a color scheme and exterior accents to match their nearby brick home. Other notable features include eye-catching Versetta stone wainscot, color-matched walk and overhead doors, and an abundance of natural light provided through large windows along the rooflines.

Post frame construction was chosen for its durability, quick construction time, and efficiency for heating and cooling.





**OUTPERFORMING
ALL OTHERS.
IMPRESSIVELY VERSATILE.**

The speed of a nail combined with the holding power of a screw. **SCRAIL**® fasteners perfectly align outstanding performance with best-in-class efficiency for faster, installation PLUS maximum holding power. The **SCRAIL**® family of fasteners is impressively versatile, with styles specifically designed to handle metal roofing to subflooring, decking to fencing, siding to crating. Explore more at www.beck-scrail.com

**SCRAIL®. FAST LIKE A NAIL.
STRONG LIKE A SCREW.**

BECK AMERICA Inc.
800-239-8665 | www.beck-america.com

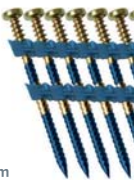

B BECK
Beyond Fastening

ColorGard®

SNOW GUARDS *for Exposed-Fastener Metal Roofs*

Protect Your Investment
...with a Reliable System.



Tested. Trusted. Engineered.

888.825.3432 | www.S-5.com |



(9) ORCHARD BUILDINGS



S-5!

www.s-5.com

LOCATION:

Upstate New York

SIZE:

Nine solar PV systems: total system size, 294.055 kW; 1,083 panels installed

ARCHITECT:

Secor Engineering

GENERAL CONTRACTOR:

Secor Building Solutions

ROOF AND WALL PANELS:

Roofs: Fabral 1½" SSR Series; Fabral Grandrib 3
Walls: Ameri-Cana Panels

PV CONTRACTOR:

LTHS Solar

ELECTRICAL CONTRACTOR:

Lauterborn Electric; Bleier Electric, Inc.

INVERTERS:

Fronius

OTHER:

Roof Clamps: S-5-PVKIT®2.0 (1,900);
S-5-S Mini Clamp (1,900)

In 1984, as a senior at Cornell University studying pomology (fruit science) and economics, Chip Bailey founded KC Bailey Orchards, a now 230-acre apple orchard in upstate New York. A first-generation farmer, Chip was always interested in orchards growing up in Wayne County, New York, the largest apple producing county east of the Mississippi. Chip and his wife, Karla, are environmentally-conscious people who understand the potential for generating renewable energy on their farm and have integrated a holistic approach to growing their 10+ varieties of apples.

On site, nine metal buildings primarily provide cold storage for their apples after harvest and prior to distribution. Each building was constructed with Ameri-Cana siding and Fabral® metal roofing. Five of the nine roofs feature direct-attach solar photovoltaics (PV). The PV was secured to the roofs with the S-5-PVKIT®2.0 solar attachment solution and S-5-S Mini clamps. The remaining structures utilize a traditional rail system.

The Bailey's chose to use metal building components not only for their lasting performance and durability, but also because of their reflective properties, which lowers the temperature of the building and enhances its cold-storage functionality.



HOME & STORAGE SHED



AMERICAN BUILDING COMPONENTS

www.abcmetalroofing.com

LOCATION:

North Carolina

SIZE:

Home: 36' x 80' x 17' tall (peak)

Shed: 40' x 40' + (3) 20' lean-tos (not shown)

BUILDER:

AW & Sons Construction,
Salisbury, North Carolina

ROOF & WALL PANELS:

American Building Components
Imperial Rib - Roof: Coal Black;
Walls: Vintage White;
Porch Ceiling: Hawaiian Blue

SNOW GUARDS:

Levi's Building Components

INSULATION:

ABT Foam board (R-10.8);
CertainTeed batt (R-19 walls),
CertainTeed blown-in (R-40
overhead)

Owners David and Janet Robertson wanted a unique and energy-efficient home for their hobby farm.

Mid-State Metals of Cleveland, North Carolina, designed the buildings and supplied builder AW & Sons Construction of Salisbury, North Carolina, with the components. "The Robertsons knew we build energy-efficient post-frame homes," says John Jancic, owner of Mid-State Metals. "They came to us looking for a home they could live in without ever having to move to a rest home; a home with everything on one level, with 36-inch doors, no carpeting or anything trippable."

STARWOOD RAFTERS, INC.
Independence, WI

GOthic ARCH MONO

GAMBREL

TIMBER TRUSS

LAM-PLY-TRUSS

RIDING ARENAS • CATTLE ENCLOSURES • STORAGE • SHOPS

- Spans up to 72 ft.
- Bird nesting control
- Up to 12 ft. spacing depending on desired load
- No feed alley post obstruction
- Additional ceiling height for more usable space

starwoodrafters.com • 715-985-3117 • 888-525-5878

MULTI-PURPOSE SHOP



HIXWOOD METAL

www.hixwoodmetal.com

SIZE:

45' x 66' x 16' sidewalls

BUILDER:

M-Z Builders

FOUNDATION:

Post-frame on 4' poured concrete frost wall

ROOF AND WALL PANELS:

Roof: Hixwood Metal SuperRib 100, 28 ga., Beckers BeckryTex coating, Burnished Slate
Walls: Hixwood Metal SuperRib 60, 29 ga, Beckers BeckryTex coating, Textured Red

DOORS:

Service: Plyco Corp.
Overhead: CHI Overhead Door

POSTS:

Richland Laminated Columns

INSULATION:

Owens Corning fiberglass R21 in walls. Applegate loose-fill cellulose insulation in ceiling

VENTILATION:

MWI Components ventilated soffit;
Marco Flex-O-Vent in ridge

FASTENERS:

East Coast Fasteners

OTHER:

Starwood Rafters:
Decorative peak accents
Trusses: 5-Star Trusses
Porch ceiling finished with carsiding











MANUFACTURERS OF QUALITY BUILDING COMPONENTS

715-644-0765 — Fax: 715-644-4931

We manufacture the industry-leading Super-Rib 9" in 26, 28 & 29 gauge. Snap-Loc manufactured to your length in 24, 26 & 28 gauge. Available in 20 smooth colors and 15 Premium Textured colors. (Total 35 colors in stock)





PHOTOS: HORTONPHOTOINC.COM

PETERSEN | PAC-CLAD

pac-clad.com

LOCATION:

Yulee, Florida

SIZE:

Total Gross: 2,658 sq. ft.

ARCHITECT:

Dasher Hurst Architects

ROOF AND WALL PANELS:

Petersen Snap-Clad standing-seam panels, 16", 24 ga., Graphite finish

SHINGLES:

Atas International CastleTop diamond-shape shingles, Silversmith finish

SIDING:

Fiberon Composite Siding in Ipe

A new Wildlight branch for First Federal Bank of Florida puts an industrial twist on basic gabled designs to create a quirky, inviting building that's highlighted with standing-seam metal panels used for both roofs and walls. Designers with the Jacksonville office of Dasher Hurst Architects were given a few guidelines from the community, according to firm principal Tom Hurst, AIA. These included siting the building close to the front property line. Elements like front porches that spur personal interactions and provide some relief from the Florida sun also are encouraged.

"It was important to them that the architecture fit into the new neighborhood, which included other commercial buildings with a decidedly 'industrial' aesthetic," Hurst says, adding that there was a bit of tension to also ensure 'industrial' didn't equate to unwelcoming. "They wanted to make sure the building felt inviting and encouraged the use of woods and other warm materials."

The most dramatic element in that palette are the standing-seam panels, which run vertically up the top half of the walls and gable ends and continue up the roof in an effort to accentuate the gabled volume, Hurst says. "We wanted the building to feel like a solid, extruded object, rather than separate walls and roof – to achieve this, we needed a material that would work equally well for both," he says. "Standing-seam metal is one of the few materials that fit this situation."



CORPORATE HEADQUARTERS



MCELROY METAL

www.mcelroymetal.com

LOCATION:

Columbia, South Carolina

METAL INSTALLER:

Aqua Seal Manufacturing & Roofing, Cayce, South Carolina

ARCHITECT:

David Sickinger, AIA, LEED AP, Principal, Garvin Design Group, Columbia, South Carolina

WALLS:

McElroy Metal, 24-ga. MSR Panel (3,665 sq. ft.) in Sherwin-Williams Fluoropon PVDF Charcoal, installed vertically. 24-ga. Wave Panel (5,597 sq. ft.) in Sherwin-Williams Fluoropon PVDF Matte Black installed horizontally.

The warehouse area of the building features McElroy's exposed fastener 24-ga. R-Panel (6,392 sq. ft.) in Charcoal.

ALUMINUM COMPOSITE MATERIAL (ACM):

Reynobond ACM (1,063 sq. ft.)



In an effort to consolidate operations in several buildings into one modern office and warehouse facility, Terminix constructed a two-story corporate office in a highly visible location along Interstate 26 in Columbia, South Carolina. Aesthetics were essential for this project so three distinct panel profiles from McElroy Metal adorn the façade.

"The exterior design expression needed to pay homage to the materials and color palette of the original structures, but in a contemporary and forward-looking way," says David Sickinger, AIA, LEED AP, at Garvin Design Group of Columbia. "Since the original buildings on this campus used a gray/beige brick and gray metal panels, the intent was to replicate those material selections as a means to provide a link to the past. The building's architecture was to be much grander in scale and open in terms of the amount of exterior glazing, so the veneer selection provided an opportunity to incorporate a sense of familiarity. However, the scale of the brick and profiles of the metal panels were changed to respond to the larger scale of the new structure."



CLASSIC CAR WORKSHOP



METL-SPAN

www.metlspan.com

LOCATION:

Adirondack Mountains, New York

SIZE: 12,000 sq. ft.

ARCHITECT: Gary McCoola, Glens Falls, New York

IMP INSTALLER:
Munter Enterprises, Saratoga Springs, New York

FRAMING:
Ceco Building Systems

ROOF AND WALL PANELS:
Roof: Metl-Span CFR, Galvalume®
Wall: Metl-Span 4" thick CF Flute panels, Medium Bronze

OVERHEAD DOORS:
Schweiss Doors, 16' x 14'

WINDOWS:
Alpen Windows 1025 Series
Fiberglass (ZR-10)

SOLAR:
Hanwha Q-Cells Panels; SolarEdge inverters; Installed by ADK Solar

A classic car enthusiast wanted a state-of-the-art facility in the Adirondack Mountains of New York. "The goal was to create a workshop and storage space for a collection of vehicles that is energy efficient, low maintenance and has the simple aesthetic of an agricultural barn," says Gary McCoola, Architect PLLC. McCoola says insulated metal panels were chosen because they provide a weather-tight exterior skin, a high thermal resistance and a pre-finished interior skin in a single component.

"On the exterior, the brown siding color was selected so the building would blend into the wooded site, particularly during the winter when foliage was down," McCoola says. "The galvanized roof color was selected to resemble that of a tin barn roof and to reflect the summer solar heat."

To add to the 12,000 sq. ft. building's efficiency, south-facing solar panels are attached to the roof. Todd Coffin, Project Coordinator for Munter Enterprises, says the biggest challenge was the complex rooflines with multiple valleys coupled with handling the length and weight of 6" thick roofing panels on a 6:12 roof pitch on a tight Adirondack woods site.



WORKSHOP



WORLDWIDE STEEL BUILDINGS

www.worldwidesteelbuildings.com

LOCATION:

Harlan, Indiana

SIZE:

48' x 55' x 12', w/ 24' x 55' x 6' monitor and (2) 15' half trusses

BI-FOLD DOOR:

Hi-Fold Door Co.

WALL PANELS:

Worldwide Steel Buildings, 29 ga.

ROOF:

Worldwide Steel Buildings
Standing Seam; asphalt shingles
(by owner)

WINDOWS:

Plyco Corp.

PLYCO

OTHER:

Steel trusses by Worldwide Steel Buildings; wood purlins and girts; stone wainscot (by owner)



MACHINERY STORAGE



WALTERS BUILDINGS

www.waltersbuildings.com

LOCATION:

Jackson, Wisconsin

SIZE:

36' x 64' w/ 11.4' heel height; 2,304 sq. ft.

ROOF AND WALL PANELS:

Walters Steel, 28ga panels:

Roof: Brown roof steel with DripStop

Walls: Red end walls

OVERHEAD DOORS:

(5) Haas #600 series w/ WiFi Jack Shaft Operator

CUPOLAS & WEATHERVANES:

MWI Components, (2) 36" cupolas, brown

MWI Components, 30" weathervanes: (1) sailboat & (1) lighthouse

OTHER:

Posts: STP mech-lam 3-ply 2x6



This custom pole barn is the perfect backyard addition for someone in need of additional machinery storage. The real beauty of the building is in the finishing touches. This building includes four overhead doors on the side wall with an additional overhead door on the back end wall. The front of the building includes our Touch of Class sliding doors, two windows, a decorative hay loft door and exterior lighting above the main entrance.

The exterior lighting is included on the side of the building over every overhead door and the walk door. The building is finished with twin cupolas on top with an LED light wired into them for a stunning final project that sparkles in the evening hours.

SOURCE BOOK PROJECT GUIDE

PRODUCTS & SERVICES

This guide will help you find the companies, suppliers, and manufacturers that provided products or services for the projects in this edition of *The Source Book*. (See each company's ad on the page indicated.)

ARCHITECTS/DESIGNERS

- Buildings By Design
- Cedar Valley Post-Frame LLC
- Dasher Hurst Architects
- Frontier Builders LLC
- Garvin Design Group
- Gary McCoola
- Jim Rothwell
- Midwest Manufacturing
- MPB Builders
- Popple River Construction LLP
- Secor Engineering

BUILDING SYSTEMS

- Ceco Building Systems
- Chief Buildings, p. 15
- Greiner Buildings
- Metallic Building Systems
- Midwest Manufacturing
- Reed's Metals, p. 18, 25
- Sukup Manufacturing Co., p. 7
- Walters Buildings
- Wick Buildings, p. 9
- Worldwide Steel Buildings

COATINGS

- AkzoNobel
- Beckers
- Sherwin-Williams Coil Coatings

BUILDING DESIGN SOFTWARE

- SmartBuild Systems

DOORS

- Acme Doors
- AJ Manufacturing
- Allmar
- CHI Overhead Doors
- Haas Door Co.
- Hi-Fold Door
- Kolbe
- Overhead Door Co.
- Palmerton Garage Door
- Plyco Corp., p. 27
- Schweiss Doors
- ThermaTru
- TruStile

FASTENERS

- AB Martin
- Atlas Bolt & Screw
- East Coast Fasteners, p. 3
- Everlast Roofing
- Ideal Fasteners
- Maze Nails, p. 2
- Metal Depots
- S-5! (clamps), p. 39
- SFS
- ST Fastening Systems, p. 11

FOUNDATION PRODUCTS

- Croell Redi-Mix
- ExpoCrete
- Perma-Column, cover, p. 31
- Post Saver
- Superior Plastic Products

INSULATION

- ABT Foam
- Applegate
- Bay Insulation
- CertainTeed
- Johns Manville

MOISTURE CONTROL

- CondensStop
- DripStop

ROOF & WALL PANELS

- AB Martin
- Ameri-Cana
- American Building Components
- Everlast Roofing
- Fabral
- Graber Post Buildings
- Hixwood Metal, cover, p. 43
- McElroy Metal
- Metal Depots
- Metal Sales
- Metl-Span
- Petersen | PAC-CLAD
- Versetta Stone

SIDING

- CertainTeed
- Fiberon
- Kebony North America, cover
- SmartSiding

SNOW MANAGEMENT

- Graber Post Buildings
- Levi's Building Components, p. 17
- Snow Jacks

SOLAR COMPONENTS

- Fronius
- Hanwha
- SolarEdge

STRUCTURAL COMPONENTS

- 5-Star Trusses
- Graber Post Buildings
- Perma-Column
- Richland Laminated Columns
- RigidPly Rafters
- Starwood Rafters

VENTILATION

- Marco Industries
- MWI Components, p. 37

WEATHER BARRIER

- Tyvek

WINDOWS

- AJ Manufacturing
- Alpen Windows
- Jeld-Wen
- Kolbe
- Plyco Corp., p. 27
- PlyGem
- Wincore
- Windgate
- YKK

OTHER

- ADK Solar
- AW & Sons Construction
- Aqua Seal Manufacturing & Roofing
- Atlas International
- Bleier Electric, Inc.
- Corporate Contractors, Inc.
- Cover's Construction
- Custom Structures, Inc.
- Delta Millworks
- Lauderborn Electric
- LTHS Solar
- Metal Sales
- M-Z Builders
- Marona Photography
- Munter Enterprises
- MWI Components, p. 37
- Original Pole Buildings
- Paul Burgin Builders
- Secor Building Solutions
- Sierra Steel
- Trident Construction

PREMIUM QUALITY ROLLFORMING MACHINERY - MADE IN THE USA SINCE 1949



ROOF & WALL PANEL LINES

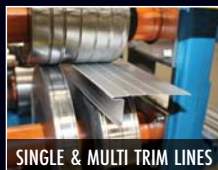

SINGLE & MULTI TRIM LINES



MEET US AT THE SHOW



TECHNOFOLD



ROLL-UP DOOR PANEL LINES



CHANNEL LINES



SLITTING LINES



COIL UPENDER



DOUBLE HEMMER

ASC MACHINE TOOLS, INC.

WWW.ASCMT.COM



TEL: (509) 534-6600



BUILDING PACKAGES

SUPPLIES & SOLUTIONS



Wick Buildings

Since our founding in 1954, Wick Buildings has become one of the nation's largest producers of post-frame buildings. Our buildings are constructed for a variety of uses, including: Residential homes and "shouses" (shop/shed house combinations); sophisticated animal confinement systems; horse housing and training facilities; on-farm storage buildings and workshops; suburban structures; municipal and church buildings; commercial, retail, and light industrial buildings.

www.wickbuildings.com
855.438.9425



Graber Post Buildings

Graber Post Buildings continues to be a phone call away for all post-frame building materials and do-it-yourself packages. GPB manufactures metal panels for any residential, commercial, industrial, agricultural or roofing application. It also produces custom trusses, metal trims, laminated poles and also features a steel coil division.

www.graberpost.com
800.264.5013



Reed's Metals

Reed's Metals, headquartered in Brookhaven, Mississippi, provides metal roofing systems, metal roofing panels, pole barns, and pre-engineered steel buildings. Reed's is comprised of nine sites utilizing state-of-the-art technology and fabrication methods. Among Reed's offerings are pre-engineered metal buildings, rigid frame buildings, Galv-Econ buildings, post-frame structures, mini storage buildings and LX Tube Building Structures.

www.reedsmetals.com
800.581.4645

ROOF & WALL PANELS



McElroy Metal

Designed for post-frame and residential applications, the Mesa panel is a patent- and copyright-protected panel with a nearly invisible lap. The Mesa panel is sure to add beauty to any project, measuring 36" wide with 3/4" high ribs. McElroy Metal, a supplier of metal wall and roofing products to the post-frame industry. McElroy Metal is a 37-time winner of the Rural Builder Gold Key of Excellence, as selected by readers.

www.mcelroymetal.com
800.950.6531



Union Corrugating Co.

Union Corrugating is a provider of metal roofing products, supplies and wall systems for residential, commercial and agricultural applications. Current residential and agricultural metal roofing options include MasterRib, ValuRib, Corrugated, 5V, SL150, Advantage-Lok II, FL100, Union Rib, TS-324, Trapezoidal Panel, 7/8 Corrugated, R/PBR/IR Panel, M Panel, SL175, ML150, and ML200. We also offer a full range of metal structural framing components including Ceess, Zees, Receiver Channel and Eave Struts.

www.unioncorrugating.com
888.685.7663



Qora Cladding

Qora Cladding is an innovative cladding product that provides builders with the time-honored look of stone within hours versus weeks. Ideal for knee wall and wainscoting accents and applications, Qora Cladding's panelized system gives you faster coverage with an expansive 6.6 SF per panel. The product will not rot, decay or burn, and provides an aesthetic quality and 20-year warranty homeowners will love. Qora Cladding in Ashlar Stone is available in five colors.

www.qoracladding.com
301.223.2266

DOORS & DOOR HARDWARE

SUPPLIES & SOLUTIONS



I-Beam Sliding Doors

Sliding Doors with Ultra Glide Track & Trolley System. Heavy duty 6,000-lb. capacity and 115 MPH wind rated. Fully adjustable: up-down, in-out. Never drag, bind or come out of adjustment. Aluminum frame doors with easy latches. Plus, Incredible Swing Doors (shown). Electric screw-jack lift for ultimate safety. Aluminum frame, fully automated door system. Easily retro-fit.

www.ibeamdoor.com
815.945.3667



Diamond Doors

Bi-fold doors for machine sheds, quonsets, and other agricultural applications. These doors are the ultimate convenience, with greaseless hinges, auto-lock upgrade, and wireless remotes. The free-standing header system can be added to hold the weight and loads of the door. The header also allows the door to extend past the roofline if needed, an option especially practical for quonset retrofit projects. Diamond Doors are competitively priced and arrive onsite fully assembled, pre-wired, and finish painted.

diamonddoors.com
833.565.0933



Plyco Corporation

If you're looking for a commercial, residential or agricultural door, Plyco has the right door for your construction projects. Contractors rely on Plyco for a comprehensive line of durable walk doors that meet today's building codes. Plyco offers pre-hung service doors individually packaged, pre-drilled for lock set, and insulated with injected polyurethane foam. Plyco walk doors are perfect for post frame, metal frame and commercial buildings.

www.plyco.com
800.558.5895



Kevmar Garage Doors

Kevmar Garage Doors is a manufacturer of quality garage doors based in Arthur, Illinois. Door sales are primarily to post frame and backyard shed builders in the Midwest. The Kevmar product line includes 15 models available in 4 colors. Doors are typically delivered directly to builders on company trucks. Kevmar models also include a line of residential specialty doors.

www.kevmarmfg.com
217.543.2828



Safe-Way Door

Safe-Way Door is a leading manufacturer of quality residential, commercial and industrial overhead garage doors in steel, wood and aluminum. Doors are available in multiple configurations including polyurethane and polystyrene insulated, uninsulated and up to 11 colors in steel and multiple powder-coat colors in aluminum. Commercial door sizes are available in all panel designs. Pictured is an Ambient Model 273 with long tinted contemporary glass in Rosewood.

www.safewaydoor.com
574.267.2813



MWI Components

Choose from thousands of color combinations for your Bale, Dutch or Arcadian Sliding Doors. MWI's completely galvanneal substrate doors come in double cross-buck or half-light options; the company also offers sliding doors in fully assembled or kit form. Finish your look with the Arcadian Sabre Slim, an exterior lockable, polished, chrome-plated handle. The keyed entry on 1-1/2" Split Sliding Arcadian Doors and interior latch functions will make your doors the talk of the industry.

www.mwicomponents.com
800.360.6467 ext. 5

FASTENERS: CLIPS & CLAMPS

SUPPLIES & SOLUTIONS



Dynamic Fastener

DYNA-CLAMPS® are a non-ferrous non-piercing clamp for attachments to standing seam metal roofs. Thirteen different DYNA-CLAMPS® with round-point setscrews are available to accommodate many different profiles of standing seam metal roofs. DYNA-CLAMPS® have undergone extensive third-party testing by Encon Technology, Tulsa, Oklahoma. DYNA-CLAMPS® are an integral part of our very popular DYNA-GUARD® snow retention system for metal roofs. All DYNA-GUARD components are extruded from aircraft quality, high tensile aluminum "6005A T61 Aluminum."

www.dynamicfastener.com
800.821.5448



S-5!

S-5!'s VersaBracket™ is a bottom-fixed, metal roof bracket specifically designed for mounting ColorGard®, solar PV and other utility mountings to exposed fastened profiles. VersaBracket is compatible with the S-5-PVKIT® for rail-less (direct-attach™) or bottom-bolted rail for solar mounting. Available in two heights (1.86" and 2.65"), VersaBracket features a 1" mounting slot on the top flange for adjustability and fastens through the roof, into the deck or structure. Factory-applied sealant ensures speedy installation and lifetime performance.

www.s-5.com
888.825.3432



AceClamp® Solar

Solar Snap™ by AceClamp® Solar™ is an adaptive, robust solar racking system built to withstand harsh High-Velocity Hurricane Zone winds up to Cat 5. Designed to work with any of AceClamp's metal roof clamps, it's an ideal solution for SSMR, Island Style Cement Cover Board Roofing, and Single-Ply. Fully assembled components make for an easy-to-use, fast-installing product. The unique cross-platform design adapts to all roof types - meaning you'll have less inventory to maintain.

www.AceClamp.com
860.479.0876

FASTENERS: NAILS & SCREWS



Everlast Roofing, Inc.

Designed for performance, Everlast Roofing, Inc. introduces The Answer RDP Woodscrew. Offering a long-life solution over standard fasteners, The Answer RDP Woodscrew performs at the same quality level as all Everlast products. Combining cross alloy mechanical plating with extra UV-resistant pigmentation, the Answer RDP Woodscrew is available to Everlast Roofing customers in 20 colors with a 40-year warranty at an affordable price.

www.everlastroofing.com
888.339.0059



Maze Nails

Add richness, sophistication and eye-appeal to all of your building projects by using Maze pre-finished nails. And, save time by eliminating the labor intensive job of touching up nail heads! Many of the sizes and colors of our "Split-Less"® Wood Siding Nails, Rubber Washer Nails, Stainless Steel Trim Nails and Fiber Cement Siding Nails are kept in stock - ready to ship. Coil and Collated stick nails are painted to match all the major Manufacturers' colors.

www.mazenails.com
800.435.5949



East Coast Fasteners

The Ply-Lo Extreme line of fasteners is designed for extreme environments. The Ply-Lo Driller is the latest innovative addition to the company's fastener line, designed to save contractors time and money. The patented Ply-Lo Driller features a design intended to be more forgiving than other fasteners. This means the tip is designed to reduce the likelihood of "walking" when fasteners are driven at a slight angle. East Coast has fasteners available in colors to match virtually any panel in lengths of 1", 1-1/2", 2", 2-1/2" and 3".

www.plyco.com
800.558.5895

FOUNDATION, COLUMN & TRUSS PRODUCTS

SUPPLIES & SOLUTIONS



Perma-Column LLC

Perma-Column® and Sturdi-Wall®: Treat yourself and your projects better. Treated lumber prices are skyrocketing while availability has hit rock bottom. Perma-Column® precast concrete columns and Sturdi-Wall® anchor brackets are the post-framing solutions of choice. Get your projects back on track. Readily available nationwide. Build better. Build stronger. Build to last.

permacolumn.com
800.622.7190



Rigidply Rafters

Glue-laminated arches, beams, posts, and timber trusses manufactured by Rigidply Rafters give beauty a completely new meaning. Rigidply also manufactures metal-plated roof and floor trusses, tongue-and-groove and V-groove decking, and offers a complete line of post-frame building materials to complete your project.

www.rigidply.com
717-866-6581



Richland Laminated Columns

Manufacture/Wholesale with national sales and service. We make and distribute Glulam Poles, Nail-lam Poles, Perma-Column precast concrete bases, Sturdi-Wall brackets, Greenpost/PlanetSaver post wrap, Post Protector/Grade Guard Sleeves and The Footing Pad. We offer several different foundation options for your post frame buildings.

419.895.0036

INSULATION/MOISTURE & VAPOR BARRIERS

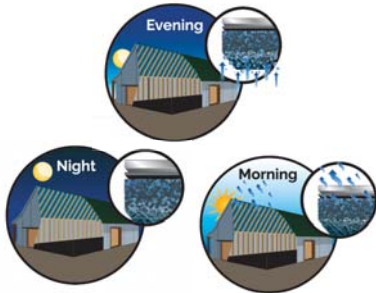

DripStop

DripStop, from Filc USA, helps fight condensation without insulation. Specially designed air pockets store condensation and hold it until conditions change and it evaporates back into humidity. DripStop arrives at the jobsite already on the steel, saving time and money by removing one step of the building process. It eliminates the need for insulation while also helping fight corrosion by adding another layer of protection from the corrosive elements found in livestock confinement.

www.dripstop.com
937.321.3000



MWI Components

Infinity Shield™ is offered in standard rolls of 4'x125' Single Bubble Foil/Foil, Double Bubble Foil/Foil, Single Bubble White/Foil and Double Bubble White/Foil. They also manufacture a no seam 6'x125' and 8'x125' roll version of all available SKUs. Infinity Shield™ is extremely cost efficient and hassle-free. Additionally, the standard crushed edge tab (2") will result in simplified overlapping. The ultra-white bubble's more opaque finish is a result of additives throughout all layers of the bubble.

www.mwicomponents.com
800.360.6467 ext. 5



Hitz Halter

Hitz Halter insulation is the choice for all below-grade applications. Its 3mil film on each side and termiticide-treated foam add long lasting value to your building. And the 4' x 24' fanfold sheets, with PEX and rebar spacings marked for you, make it a breeze to install!

HitzHalter@HersheysMM.com
877.661.3030

TOOLS & EQUIPMENT

SUPPLIES & SOLUTIONS

SOFTWARE

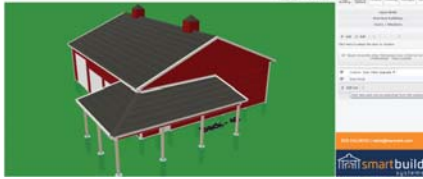

SmartBuild Systems

SmartBuild is a software system that empowers users to create custom designs for post-frame structures. SmartBuild uses cutting-edge technology to deliver complete 3D interactive input in a user-friendly web-based environment. Users are guided through a simple, menu-driven set of prompts to design any custom building. SmartBuild automatically creates framing, sheathing and trim cut lists, material lists, pricing, and drawings to make ordering materials streamlined.

www.smartbuildsystems.com
303.579.6277

CONTRACTORS...

now you can perforate your
AG Panels AND FLAT STOCK
with the **AG PANEL PERFORATOR!**



- HD Electric - Gearbox Drive
- Four (4) Sets of Perf Dies
- 29 - 26 ga. Steel for AG Panels
- 29 - 24 ga. Steel, .032" Aluminum - Flat Stock

 **ROLL FORMER CORPORATION**

Call us today at 215-997-2511
www.rollformercorp.com



ASC Machine Tools, Inc.

ASC Machine Tools, Inc. designs and manufactures a variety of rollforming lines for the production of roll up door panel, track and bottom bar profiles. In addition ASC offers custom built seaming stations and automated drum roll-up stations to complete your set up. All of our equipment is made in Spokane, Washington, USA.

www.ascmt.com
509.534.6600



BECK America

Meet the family of FASCO® (member of the BECK Group) Jumbo Nailers that is perfect for projects that require workers to use 4" to 6-1/4" nails. The sheer efficiency by which you can work will automatically put more money in your pocket after only a few uses. Pair with our Jumbo Nails or SCRAIL® that come in a wide variety of finishes including our patented Diamond Coating. No more hammering by hand!

www.beck-america.com
800.239.TOOL (8665)



Metal Rollforming Systems

Metal Rollforming Systems (MRS) designs and manufactures industry-leading roll-forming equipment and accessories. The MRS product lines consist of single- and double-deck roll formers, single- and multi-trim roll formers, slitters, and more. MRS takes great pride in customer support both before and after the sale.

www.mrsrollform.com
888.284.6794



Acu-Form

Acu-Form Panel Lines with new controllers are built for more accuracy and consistency with longevity and ease of operation in mind, while producing precise parts in a variety of profiles, including custom matches. Saving you time which is money. All our forming dies are made from D2 tool steel for a longer wear life. These machines can be powered by electric, hydraulic or mechanical.

www.acuformequipment.com
330.674.4003

VENTILATION

SUPPLIES & SOLUTIONS



MWI Components

MWI offers a large color palette with over 100 colors for ridge vents to match most roll formers' metal panels. Additionally, MWI supplies Uni-Vent II and Uni-Vent III (to ventilate with a ridge cap) and manufactures two high and three low profiles of Ridg-Vents for outstanding ventilation. To prevent rust stains and ease of handling, the vents have no raw metal edges. MWI is a leading manufacturer of steel and aluminum soffit. Pre-cut or special cut lengths are available, and sizes range from 7-144".

www.mwicomponents.com
800.360.6467 ext. 5



Golden Rule Fasteners

Golden Rule Fasteners stocks profile-specific 25' rolls and 3' sticks of ridge vent for metal roofs as well as 20' rolls of non-profile-specific ridge vent. Let us help you source your ridge vent, screws, rivets, butyl tape, silicone sealant, pipe flashings, and more all in one place, where most orders ship same day.

www.goldenrulefastenersinc.com
334.283.4030



Plyco Corporation

Plyco manufactures and distributes a variety of ventilation products designed to meet most airflow requirements. The MWE-100 is a low profile unit, 10' in length with 12 sq. in. free air space per lineal foot. The MW100-25 has a higher profile than the MWE and is open at the top. The ventilator has an internal diverter to direct rain off to the side and out onto the roof. The MW100-35 has the same design as the 25 series with increased free air space of 36 sq. in./ lineal foot.

www.plyco.com
800.558.5895

WINDOWS & DAYLIGHTING

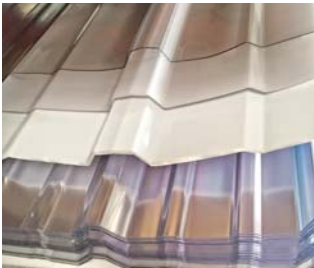

Direct Metals Inc.

Direct Metals Inc. (DMI) distributors have the flexibility to offer many choices in daylighting options including profiled and flat monolithic translucent panels. Profiled panels are available in different strength ratings and thicknesses: 1.0mm, 1.5mm and 2.0mm. Custom panel profile-matching technology is available to your customers where DMI can create a custom translucent panel using your CAD drawing (minimum orders apply). All panels are co-extruded with UV protection.

www.directmetalsinc.com
855.800.8878



Palram Americas

Sunsky polycarbonate is a leading corrugated product for skylights, sidelights and complete roofs. Weighing half the weight of glass, SUNSKY also offers these advantages over traditional FRP: will not bloom, up to 20 times greater impact resistance, the highest light transmission rates, the lowest yellowing index, the highest load rating, and the highest resistance to wind uplift. Available in clear or light diffusing tints, and hundreds of profiles to match most existing metal profiles.

www.palram.com/us
800.999.9459



A.J. Manufacturing

A.J. Manufacturing offers a complete line of durable high-quality Harmony vinyl and Main Street vinyl windows. Options include standard and custom colors, horizontal sliding, fixed lite, casement, single hung, double hung, architectural shapes, grids, and Low-E glass. White, brown, bronze, champagne, clay or custom-colored windows and trim will enhance the appearance of your next building.

www.ajdoor.com
800.328.9448

GET MORE INFORMATION ABOUT PRODUCTS & SERVICES SEEN IN THIS ISSUE. HERE'S HOW:



If you are looking for more information from companies featured in this issue, fill out this form.

Mail the completed form to us, and we will have those companies get in touch with you. There's no need to fill out multiple forms; we'll do the legwork for you.

Name (please print) _____

Signature (required) _____

Company _____

Address _____

City _____ State _____ Zip _____

Telephone (_____) _____

E-mail _____ Date _____

Please check one or more boxes to subscribe FREE/Renew for 3 years:

- Garage, Shed & Carport Builder Magazine*
 Frame Building News
 Metal Roofing Magazine
 Rural Builder
 Rollforming Magazine
 Roofing Elements Magazine

I would like to receive my subscription: By Mail Digitally

- Check this box if you wish to receive our Builders' Express newsletter and offers from our partners.
 Check this box if you wish to receive our Roofers' Express newsletter and offers from our partners.

Email address is required to receive newsletter.

CONTACT NAME & EMAIL (OR) NAME & PHONE NUMBER ARE REQUIRED. WITHOUT THIS INFORMATION WE WILL NOT PROCESS THE REQUEST.

SELECT A MAXIMUM OF 5 COMPANIES TO REQUEST INFORMATION FROM:

Company Name: _____ PAGE: _____

Company Name: _____ PAGE: _____

Company Name: _____ PAGE: _____

Company Name: _____ PAGE: _____

Company Name: _____ PAGE: _____

I understand that by providing the above information I hereby consent to receive communication regarding my subscription via US Mail, telephone, and e-mail sent by *Rural Builder*.

Valid until Nov. 30, 2021

RB AUGUST 2021

CHECK WHICH TITLE APPLIES TO YOU:

- President
- Owner
- Partner
- General Manager
- Sales Manager/Rep
- Engineer/Architect
- Vice President
- Foreman
- Installer
- Other _____

PLEASE CHECK THE PRIMARY CATEGORY THAT DESCRIBES YOUR BUSINESS:

- Builder, Dealer, Remodeler or Installer
- Roofing Contractor
- Metal Roofing Contractor
- Building Material Dealer/Distributor
- General Contractor/Remodeler
- Manufacturer/Rep of Manufacturer
- Architect/Specifier
- Construction Consultant/Engineer
- Building Owner/Developer
- Other (Please Specify) _____

ENGAGED IN THE FOLLOWING APPLICATIONS:

- Gutters/Accessories
- Institutional
- Residential
- Agricultural
- Commercial
- Industrial

calendar

BY RURAL BUILDER STAFF

Before making travel arrangements, check with the show producer to confirm there have been no changes to event dates, venue, or show hours.

SEPTEMBER

13-16, FABTECH, McCormick Place, 2301 S. King Dr., Chicago, Illinois. fabtechexpo.com

21-23, Western Roofing Expo, The Mirage, Las Vegas, Nevada. www.westernroofingexpo.com

21-23, Associated General Contractors (AGC) Annual Convention, Orlando World Center Marriott, Orlando, Florida. convention.agc.org

21-23, Greenbuild International Conference + Expo, San Diego Convention Center, San Diego, California. <https://informaconnect.com/greenbuild/>

OCTOBER

4-8, Building Component Manufacturers Conference, CHI Health Center, Omaha, Nebraska. <https://bcmcshow.com/>

6-8, METALCON, Tampa Convention Center, Tampa, Florida. www.metalcon.com



PLASTISLEEVE®
POST PROTECTION
TYPICAL POST FRAME DESIGN

The "Original" post protector

- Low cost - Easy slide on
- Made from the best, HDPE black plastic!

sales@plastisleeve.com
Toll free 877-775-3383
www.plastisleeve.com

index of advertisers

Company	Page #
Acu-Form	17
AJ Manufacturing	26, 32, 38
Ames Research Laboratories Inc	17
ASC Machine Tools	17, 49
BECK America	39
Best Products	22
Bradbury Group, The	18, 57
Chief Buildings	15
Direct Metals Inc	17
Dynamic Fastener	BC
East Coast Fasteners	3, 42
Everlast Roofing	23, 28
Golden Rule Fasteners	17, 35
Graber Post Buildings, Inc.	10, 36
Hershey's Metal Meister	33
Hixwood Metal	CVR, 43
I Beam Sliding Doors	29
Johnson Bros. Roll Forming Co.	17
Kebony North America	CVR
Kevmar Mfg.	17
Leland Industries Inc.	21
Levi's Building Components	17
Marco Products	26, 42
Marion Manufacturing	57

Company	Page #
Maze Nails	IFC
McElroy Metal	32, 45
Metal Rollforming Systems	22
Michiana Quality Roofing	18
MWI Components	8, 28, 36-38, 42, 48
Perma-Column LLC	CVR, 31
Planet Saver Industries	18
Plasti-Sleeve	57
Plyco	8, 23, 27-28, 42, 47
Reed's Metals	18, 25
Rigidply Rafters	26, 38
Roll Former Corporation	54
S-5!	39
Safeway Door	18
Snow Stoppers	18
ST Fastening Systems	11
Starwood Rafters	41
Stockade Buildings	18
Sukup Manufacturing	7
SWI Machinery	13
Union Corrugating	16
United Steel Supply	18
Universal Tube & Rollform Equipment Co	16
Wick Buildings	CVR, 9

NOVEMBER

4-5, Garage, Shed & Carport Builder Show, Century Center, South Bend, Indiana. 715-252-6360; <https://garageshedcarportbuilder.com/show-registration/>

DECEMBER

6-8, Construction SuperConference, J.W. Marriott Bonnett Creek, Orlando, Florida. constructionsuperconference.com



THE BRADBURY GROUP

We Build Machines.
We Sell Solutions.

- | | |
|-------------------|-----------------------|
| Panel Lines | Portable Roll Formers |
| Purlin Lines | Insulated Panel Lines |
| Control Retrofits | Standing Seam Lines |
| Hydraulic Folders | Garage Door Lines |
| Trim Roll Formers | Slit & Recoil Lines |



www.bradburygroup.com 620.345.6394



MARION MANUFACTURING

- Automation Systems
- Metal Construction Rollformers
- Coil Processing
- Forming & Fabrication
- Recondition Existing Machines

WE ADD THE VALUE TO METAL
1-888-865-8740 www.marionmanufacturing.com

CHECK WITH YOUR SUPPLIERS FOR

GARAGE • SHED • CARPORT

BUILDER SHOW

SOUTH BEND, INDIANA
NOVEMBER 4-5, 2021

ENTRANCE FEE: \$50 in advance - \$60 at the door

TO EXHIBIT: gary@shieldwallmedia.com • 715-252-6360

TO REGISTER: www.garageshedcarportshow.com/show-registration



FOR HOTEL RESERVATION:

DoubleTree by Hilton South Bend

WEB: <https://bit.ly/3rpLu76>

PHONE: 1-800-HILTONS

ROOM RATE: \$99

Group Code: TGC



FREE PASSES!



ASTA AMERICA
BY JANUS INTERNATIONAL



THE BRADBURY GROUP



SAFE-WAY
GARAGE DOORS
Make a Statement.

DYNA-GUARD®



IT IS TIME FOR A
**CHANGING OF THE
GUARD**

S-5!® We are discontinu-
ing the line of S-5!®
snow retention products. Closeout/
below cost prices on S-5!®

X-Clip™ II	\$2.75
X-Gard™ 1.0 Bracket	\$1.85
X-Gard 2.0 Bracket	\$4.50
S5S Stainless Mini Clamp	13.85
SnoClip™ II	\$1.35

DYNA-GUARD® Snow Retention System installed on a metal roof.



DYNA-CLIP®

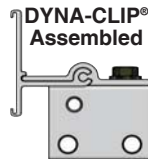

DYNA-CLIP®
Assembled

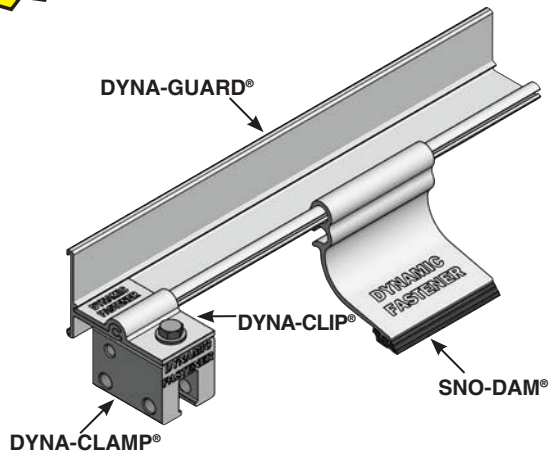

DYNA-GUARD®

DYNA-CLIP®

DYNA-CLAMP®

SNO-DAM®

Our Dyna-Guard® system comes with a *free* 30-year warranty.

Attention architects / specifiers:

ARCAT® For a CSI 3 part specification and CAD details on
DYNA-GUARD products see our page on Arcat

<https://www.arcat.com/arcatcos/cos50/arc50660.html>



Hover over this code with
your smart device's camera
to land at our ARCAT page.