

POST-FRAME BUILDER SHOW PREVIEW

CONNECTING BUYERS & SELLERS • EXHIBITOR PROFILES
REASONS TO ATTEND • EXPLORE BRANSON

MAY 2024
Vol. 58, Issue 3

Rural Builder

Serving The Construction Trade Since 1967

www.ruralbuildermagazine.com

**FRAME
BUILDING
EXPO
POST SHOW
REPORT**

POST-FRAME BUILDER SHOW

**JUNE 19-20, 2024
BRANSON, MO**

**SEE US AT THE POST-FRAME BUILDING SHOW
SHOW PREVIEW + FLOOR MAP INSIDE**

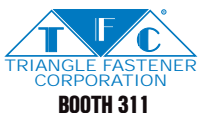

**AVOIDING
CORROSION
IN AG BUILDINGS**

THE COIL HANDLING SOLUTIONS YOU NEED TO MAXIMIZE EFFICIENCY & MINIMIZE WASTE.

SWI's Reliable, Fast & Easy-To-Operate
Systems Ramp Up Any Sheet Metal Project.



Marxman Pro

The Marxman Pro is one of the most advanced sheet metal blanking systems on the market. **Automatic knife setup and auto nesting** ensure all jobs are processed quickly and with minimal material waste. Plus, with the Pro's part cut system, you can part cut ANY slit, even in the middle of a sheet, with no damage to adjacent parts. Or, when all parts are the same length, simply use the guillotine shear to cut them all to length.

The Marxman Pro also comes standard with an **automatic labeling system**, which applies custom printed barcodes to each part, allowing you to move, scan, and load projects between slitter and folder with minimal downtime and reduced risk of operator error.

SWI Marxman Pro
Automatic Slitter

Twin Mandrel Capstan Uncoilers

These rugged uncoilers (available in capacities of 12,000lbs and 5,000lbs) have the capability of safely loading or unloading one coil while running a job on another and quickly switching between the two to maximize production time.

We've been manufacturing our Twin Mandrel Uncoilers for more than 20 years, with many in high-volume, double-shift operations. Another amazing perk is that they can be paired with any preexisting rollforming machines your business already utilizes making them the perfect economical solution where fast coil changeover is required with minimal fuss.

For Full Catalog or Quote:

(770) 766-0880 • info@swimachinery.com • SWImachinery.com



12,000lbs Twin Mandrel
Capstan Uncoiler



5,000lbs Twin Mandrel
Capstan Uncoiler



EDITOR'S NOTE

BY DAN BROWNELL



Building on Success

I would like to introduce myself as your new editor. I consider it a privilege and look forward to continuing *Rural Builder's* tradition of delivering practical, timely information to help you save time and money and to improve your bottom line.

POST-FRAME BUILDER SHOW IN BRANSON

You don't want to miss this opportunity to meet manufacturer reps and see their newest products in person. And, of course, there's the networking and educational opportunities as well. Industry experts will be there to present seminars on key topics. All this will take place June 19-20 in beautiful, family-friendly Branson, Missouri. Check out the in-depth information on the show inside this issue. Make plans now to bring your family and make it a working vacation. Reservations are filling fast, so don't wait.

AUGUST SOURCE BOOK SUBMISSIONS

We would like to invite you to submit projects for our August Source Book issue. If you haven't submitted one yet, here's the

link: shieldwallmedia.com/rural-builder-source-book-project-submission-form. Or click on the link on the *Rural Builder* website.

We're also accepting submissions for each issue's Project of the Month. These projects are a great way to get the word out about your company, and an excellent source for ideas and inspiration for our readers. Just upload some high-resolution photos, tell us briefly about the project, and list the key manufacturers and products you used. Use the same submission link above.

ARTICLE TOPIC SUGGESTIONS WELCOME

We want to cover the topics and information you find most important. Feel free to send me an email with your ideas, suggestions, and feedback to dan@shieldwallmedia.com. If you would like your company to be considered for a business profile article, let me know that as well. We look forward to hearing from you.

To Your Success!

Dan Brownell, Editor

Barndominium Design With SmartBuild



The market is changing. Your customers demand more. They are fickle. They expect instant information. They rapidly change their minds and expect quick responses. To compete in this landscape, you'll need to turn around bids faster. You'll need to provide accurate quotes LIVE in the field.



3.5 hours → 15 minutes

Standard post frame designs that once took 3 1/2 hours, can now be completed in 15 minutes.



10 hours → 30 minutes

Barndominium designs that once took 10 hours, can now be completed in 30 minutes.

GET YOUR UNFAIR SHARE OF
THE BARNDOMINIUM MARKET.

Keith Dietzen • 303-579-6277

smartbuildsystems.com • sales@keymark.com





51

CONTENTS

features



8

6 MIKE ROWE FOUNDATION
Miguel Gomez Finds His Dream Career

8 TEAM RUBICON
160,000 Disaster Relief Volunteers Are Making an Impact Around the World

14 POST-FRAME BUILDER SHOW PREVIEW
Build Contacts and Expand Your Business in Branson, Missouri, June 19-20

20 FAMILY FUN IN BRANSON
Where to Eat, What to Do, How to Get Around

24 PRODUCT FEATURE: NON-CORROSIVE PANELS
Avoiding Corrosion in Ag Buildings

30 POST-FRAME BUILDER SHOW PULLOUT EXHIBITOR MAP

48 MANUFACTURER PROFILE
Amerilux International

51 PROJECT OF THE MONTH
Worldwide Steel Buildings Presents a Post-Frame Barn-Style Home

55 FRAME BUILDING EXPO SHOW REPORT
News From the March Show in De Moines

DEPARTMENTS

Editor's Note 3
 Business Connections.....52
 Construction Survey Insights...59



JULY PREVIEW

- Gold Key Awards
- Ventilation for Livestock Buildings
- Radiant Floor Heating

POST-FRAME BUILDER SHOW PREVIEW
 CONNECTING BUYERS & SELLERS • EXHIBITOR PROFILES
 REASONS TO ATTEND • EXPLORE BRANSON

Rural Builder
 Serving The Construction Trade Since 1967
 www.ruralbuildermagazine.com

MAY 2024
 Vol. 58 Issue 3

FRAME BUILDING EXPO POST SHOW REPORT

POST-FRAME BUILDER SHOW
 JUNE 19-20, 2024
 BRANSON, MO

AVOIDING CORROSION IN AG BUILDINGS

SEE US AT THE POST-FRAME BUILDING SHOW
 SHOW PREVIEW | FLOOR PLAN | HOUSE

BOOTH 011 | BOOTH 012 | BOOTH 013 | BOOTH 014 | BOOTH 015 | BOOTH 016 | BOOTH 017 | BOOTH 018 | BOOTH 019 | BOOTH 020

ON THE COVER:

Join us for the Post-Frame Builder Show, June 19-20 in beautiful, family-friendly Branson, Missouri.

INDEX OF ADVERTISERS

Company	Page #
Acu-Form	29, 49, 53
AmeriLux International	49
Ameripak Inc	54
ASC Machine Tools Inc	52
Aztec Washer Company	27, 52
Buffalo River Truss LLC	29
Diamond Building Supply	29
Direct Metals Inc	52
Dripstop®	BC
Dynamic Fastener	21
Everlast Roofing, Inc	13, 52
FootingPad	29, 43
Frontier Metal LLC	29
Golden Rule Fasteners	53
Hixwood	29, 45
Janus International Group	11
Kevmar Manufacturing	53
Levi's Building Components	37
Malco Tools, Inc	29
Marco Industries	29
Marion Manufacturing	52
Maze Nails	9
Metal Rollforming Systems	39
Mid South Aluminum	19
MWI Components	25
Palram Americas	CVR, 26
Perma-Column LLC	7, 29, 52
Planet Saver Industries / GreenPost	52
Red Dot Products, LLC	50, 53
RetroFitClip	53
rFOIL Reflective Insulation	50, 53
Richland Laminated Columns	29, 35
Rigidply Rafters	41
Sims Steel	52
SmartBuild Systems	3
Snap Z	29
SpeedLap LLC	CVR, 29
Starwood Rafters	47
Steel Dynamics	17
SteelGrip SAMM, Inc	53
SWI Machinery	IFC
T&H Lemont	29
Trac-Rite Door	CVR, 23, 29
Triangle Fastener Corporation	CVR, 28
United Steel Supply	CVR, 53
Weaver Tool Gear	29
Wildcat LLC	29
Wintech Inc	29
ViWintech Windows & Doors	29

**GO TO PAGE 15 TO
 SUBSCRIBE
 TO MORE
 FREE MAGAZINES**

Rural Builder®

Managing Editor
 Dan Brownwll
 dan@shieldwallmedia.com



Editorial Staff
 Karen Knapstein, Linda Schmid

Circulation/Subscriptions
 Barb Prill
 barb@shieldwallmedia.com
 920-471-4846

Publisher/CEO
 Gary Reichert
 gary@shieldwallmedia.com
 715-252-6360

Director of Events
 Missy Beyer
 missy@shieldwallmedia.com
 920-216-3007

Executive/Advertising Assistant
 Kathy Budsberg
 kathy@shieldwallmedia.com

Advertising/Show Assistant
 Cari Ullom
 cari@shieldwallmedia.com

Graphic Designers
 Tom Nelsen
 Kevin Ulrich

Rural Builder (ISSN: 0888-3025) (Volume 58, Issue 3) is published ten times per year (February, March, May, June, July, August, September, Annual, October and December) by Shield Wall Media LLC, 150 Depot St., Iola, WI 54945. Periodical postage paid at Iola, WI, and at additional mailing offices. Canadian Agreement Number: 40665675. POSTMASTER: Send address changes to Rural Builder, Barb Prill, PO BOX 255, Iola, WI 54945. Copyright 2024 Shield Wall Media LLC. Rural Builder and its logo are registered trademarks. Other names and logos referred to or displayed in editorial or advertising content may be trademarked or copyright. Rural Builder assumes no responsibility for unsolicited materials sent to it. Publisher and advertisers are not liable for typographical errors that may appear in prices or descriptions in advertisements. Mailed free to rural contractors and their suppliers throughout North America. Others may subscribe: \$29.98 for 1 year, \$55.98 for 2 years, and \$79.98 for 3 years in the U.S.; \$39.98 for 1 year, \$74.98 for 2 years in Canada.

YOUR PRIVACY IS IMPORTANT TO US

Unrelated third parties often attempt to sell mailing lists for what they say are our publications. You can be assured that WE DO NOT, HAVE NOT, AND WILL NOT EVER SELL OUR SUBSCRIBER LISTS. We will also NOT sell the attendee or exhibitor lists from our shows. We do provide attendee lists to the exhibitors free of charge and as a courtesy for their support, but we NEVER provide this or any other information to independent vendors.

Gary Reichert,
 Publisher, Shield Wall Media



e-mail the editor at
 dan@shieldwallmedia.com

Visit our website:

www.ruralbuildermagazine.com



Scholarship Winner Got the Career of His Dreams

Miguel Gomez' Unbeatable Attitude Made it Happen

BY LINDA SCHMID

When you meet Miguel Gomez and talk to him about his work, you can't help but smile. His enthusiasm is infectious. He is doing what he always dreamed of doing; working as a plumber.

That may seem like an unusual dream to many young people, after all so many are told that they should focus on getting into college so they won't have to do trade work. Miguel said that people told him that too, but he ignored it.

Miguel was always curious about how things worked. When he was small he wondered why the shower water got hotter when someone flushed the toilet. When a repairman came, he followed him around like a puppy asking questions.

WORKING TOWARD A GOAL

As he got older, his uncle, a plumber, took him under his wing. From sixth grade through high school, he worked for his uncle's shop, Molina's Plumbing. Eventually he could run some jobs himself.

In 2011, Miguel went to work for Bill Howe Plumbing, Heating & Air. The company encourages their employees to take classes at the trade school, even paying the tuition. A year or two later, Miguel started classes.

When his employer encouraged the students to apply for scholarships, Miguel applied for three or four of them. "It was difficult writing essays," Miguel said, "It brought up a lot of memories about my past. Growing up, we were poor, first generation Mex-



ican-Americans, and we had a hard time of it."

EARNING A MIKEROVEWORKS SCHOLARSHIP

Until he applied for the scholarship, Miguel had never even heard of Mike Rowe because he had never watched much television; he always worked. However, when he decided to apply, he watched a few reruns of "Dirty Jobs," and he thought it was so important that Mike was showing everyone what tradespeople's jobs are about.

"It's wonderful that he is getting the word out that there are lots of opportunities out there besides sitting at a desk," Miguel said.

Awarded a mikeroweWORKS scholarship that paid for his textbooks gained him recognition at work, as such inputs help his employer to continue educating employees.

Part of the scholarship process requires Miguel to take the Foundation's Sweat Pledge. The pledge tallied with his outlook, but his favorite part was the statement that everyone is created equal. Miguel knows this to be true, although he has not always been treated equally.

FURTHERING HIS EDUCATION

The first couple of years of trade school were pretty easy for Miguel; he already knew the basics. Then, he moved into sizing and all of the calculations involved with that part of the job, and it became more challenging. But he persevered and earned his journeyman's certificate. Miguel is very proud of this accomplishment.



As a result of a collaboration with mikeroweWORKS Foundation (www.mikeroweworks.org), *Rural Builder* is featuring profiles of Work Ethic Scholarship recipients in each of its issues. Over 1,500 scholarships have been awarded to trade-school students who value hard work and taking personal responsibility. *Rural Builder* applauds these students and wants to acknowledge their choice to apply their talents to skilled trades. Thank you, mikeroweWORKS Foundation, for your continuing efforts to close the skills gap and "reconnect the average American with the value of a skilled workforce."



“As a first-generation American, I have planted my flag and become the person my uncle said I could: a journeyman plumber with a contractor’s license.

“People tried to put my decision down,” Miguel said. “They said I should go to school to become a lawyer. But that doesn’t work for me; I like to be up and active.”

ON THE JOB

People also harassed him because of his skin color. They would make comments like “You look more like a landscaper.”

“I’m comfortable in my skin,” Miguel said. “You can say stuff about me and I’ll still fix your plumbing problem,” he added.

If it gets too tense, Miguel knows he can call the office and ask for someone else to come out. The few times he’s done that, he found that his employer had his back. They told the customer, “We don’t want your business if you can’t treat our people with respect.”

You might think that such incidences could dampen Miguel’s enthusiasm for his work, but it’s not so. He loves his work and believes it has made him a better person. “Look at me now,” he said, “I started as no one, and now I am a manager,” he added.

Miguel trains the next generation of Bill Howe employees. He is glad to share all of the knowledge he has been given with others learning the trade. He is not sure what the future will bring, but he said, “I enjoy training young people to be better in their jobs and in their lives. I think I can be happy doing this forever.” **RB**

POST-FRAME PROFESSIONALS BUILD ON PERMANENT FOUNDATIONS



Precast concrete
3X stronger than
standard concrete

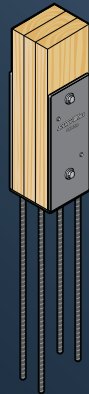
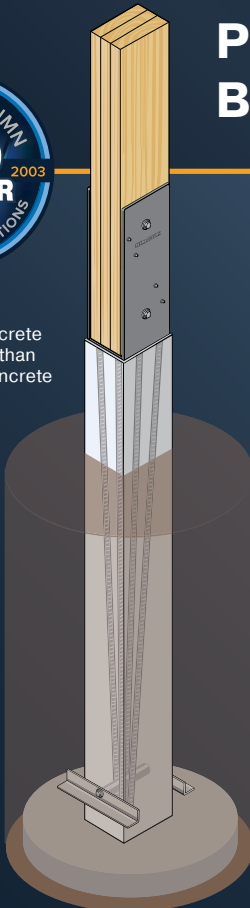

Powder-coated
steel brackets

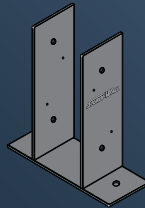

Elevate your building projects with engineered foundation solutions that combine the economy of post-frame construction with the durability of a concrete foundation.

- Eliminate wood in the ground
- Maximize post-frame building life
- ICC-ES-certified code compliant

Build better. Build stronger. Build to last.
Contact your distributor today!



Certified by the International
Code Council to meet residential
and building codes



permacolumn.com

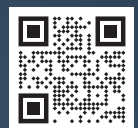

Team Rubicon: Helping People in Crisis

Working Toward More Resilient Communities

You may have heard of Team Rubicon, a humanitarian organization with local volunteers, or Greyshirts as they call them, in every state. The organization has grown from its inception 14 years ago when Jacob Wood, a Marine, pitched in to help Haiti after the 2010 hurricane that devastated the island. He met eight other volunteers during this mission, and they banded together to start a volunteer organization. Today Team Rubicon includes 160,000 Greyshirts. Once you find out a bit about Team Rubicon, you will understand how they manage to recruit so many volunteers!

TEAM GOALS

Devon Miller, Sr. Communications Associate, explained that Team Rubicon engages in three phases of relief: mitigation, response, and recovery. Response is the part of their work that people are likely to hear about; it's the part that the media reports on, but all three phases are important.

Mitigation is about helping people to become prepared and even avoid problems when disasters strike. For example, clearing away the brush and flammable items from yards where wildfires are a threat and sandbagging in areas that suffer from flooding.

Response is about showing up when disaster strikes and doing what needs to be done. This often means clearing the route so first responders can get to the people



Hawaii Donations Management

who need attention and organizing volunteers.

Recovery is about helping people get back into their homes. Sometimes that entails repairs and sometimes that requires rebuilding. The organization employs local tradespeople for these projects with the mindset that the money spent is invested into the local economy.

DOMESTIC & INTERNATIONAL SERVICES

The goal of the domestic services is to develop a bank of volunteers across the US that can jump into action when needed.

Local volunteers who know the area and work to develop connections with local leaders and communities is invaluable. In times of crisis, they can help the team to find the areas where they are most needed, as well as helping them with places to shelter. Besides the local people, they have about 40,000 Greyshirts who will deploy to crisis areas as needed.

The International operation has many of the same goals as the domestic team, but there is greater focus on medical services, water, and hygiene. This is because these items are often scarce in the environment even before the disaster or crisis



NAIL IT RIGHT EVERY TIME



Maze Premium Post Frame Nails

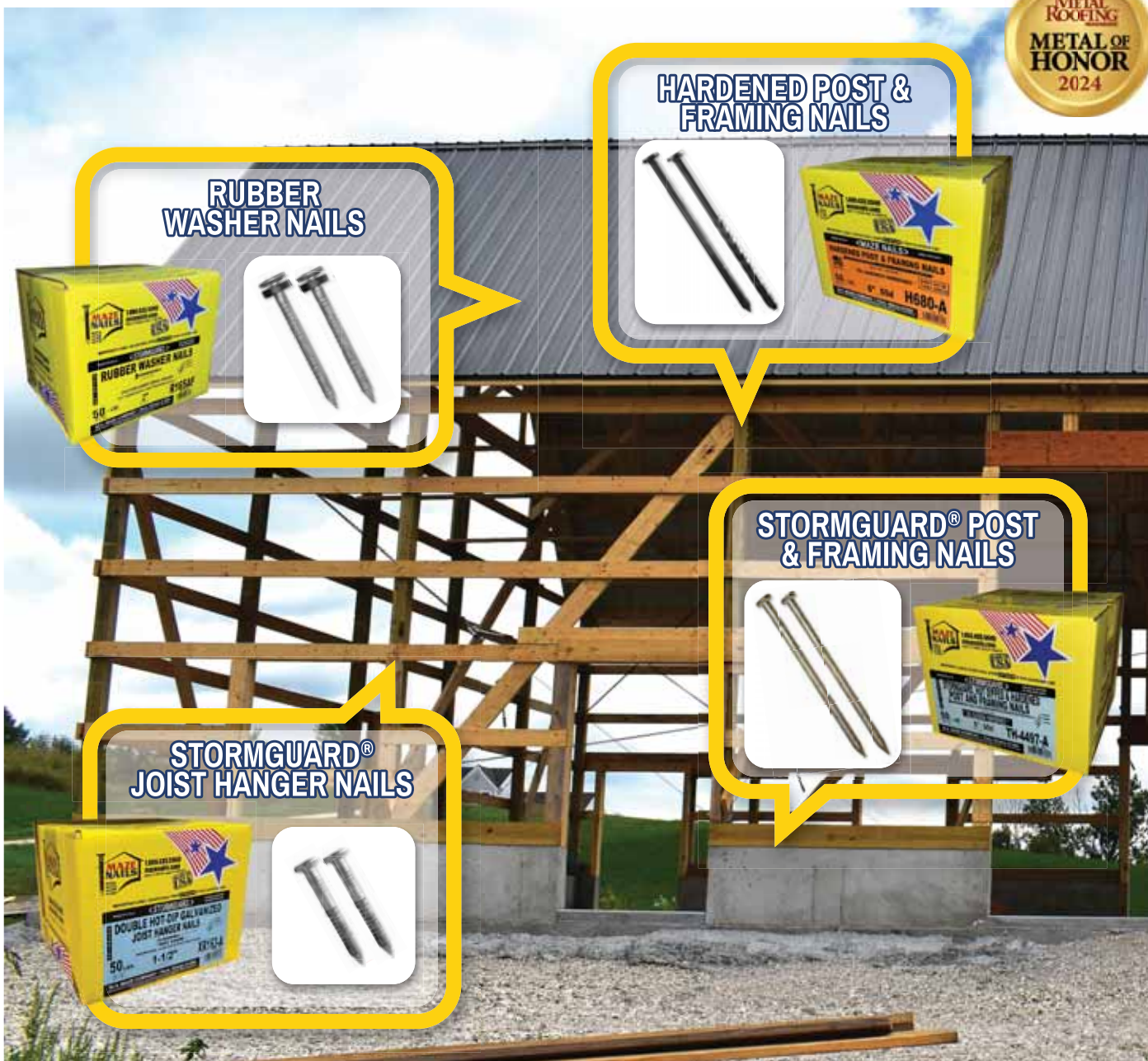

**RUBBER
WASHER NAILS**



**HARDENED POST &
FRAMING NAILS**

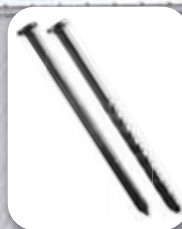

**STORMGUARD® POST
& FRAMING NAILS**



**STORMGUARD®
JOIST HANGER NAILS**



1.800.435.5949 | mazenails.com

hit. Team Rubicon deploys mobile medical units, type 1, which means they are small and able to reach remote areas, and they are self-sustaining so the volunteers are not using resources that the locals need.

TEAM RUBICON IN HAWAII

Team Rubicon was fortunate enough to be part of the initial response to the recent, devastating wildfires on Maui. Erin O'Rourke, Operations Manager, said they operated in the up-country region of Kula, which was hit by the same fire that did so much damage in Lahaina. Their operation consisted of clearing the access route to the area, managing local volunteers, and handling the donations that came in. Post-disaster work is continuing in the region.

THE VETERAN CONNECTION

With labor shortages what they are, especially in hands-on work like the trades, one might think that it would be hard to find workers and volunteers to fulfill the team's mission. One great resource is veterans.

The organization was developed by a veteran, and O'Rourke

said, "We have found that military people are especially suited to do this work. They have the grit and determination we need."

She explained that their volunteer activities depend on what is needed in each individual case, but often Greyshirts use power saws to cut up trees and remove them from the access route and perform other manual labor. They work in grim circumstances and may be subjected to stark living conditions, and these are things that veterans have generally experienced before.

"Working with Team Rubicon often gives veterans a sense of purpose that they may be missing after they leave the service," O'Rourke said.

Miller estimates that about half of their volunteers are veterans. Training is provided to Greyshirts for such things as using power tools and leadership training, and some veterans have taken the skills they have developed with the organization and found employment opportunities, such as firefighting, working for FEMA, or as EMTs.

THE TRADES ACADEMY

Team Rubicon is working on a new initiative; they are developing a Trades Academy. The mission is to train people in skills





JANUS
INTERNATIONAL GROUP



WE GOAT THIS.

No one beats Janus doors – ya' herd?

Selecting a Janus roll-up door for your building makes you the **G.O.A.T.** of decision-making. Our American-made doors outlast the competition, saving you money on costly repairs and maintenance. Spiral barrels and tension holding devices provide superior strength, meaning you get the toughest, most reliable doors around.

Janus roll-up doors are **UDDERLY AMAZING** and will **BALE YOU OUT EVERY TIME**.

JanusIntl.com



To learn more about **JANUS DOORS**,
scan here or call **770-562-2850**.





Volunteers in Action



such as carpentry, HVAC, and electrical work so they will be able to better help with recovery, getting people back in their homes.

The Academy's goal is to provide tuition-free training with the help of generous sponsors and partners like the A. James & Alice B. Clark Foundation. The academy will be open to all, as O'Rourke said, it's for "people who want to give their time and make the world a better place."

SUPPORTING THE MISSION

During a natural disaster, war, or a pandemic, people need many things. Miller quoted founder, Jake Wood, "There are a thousand things that are more important than money, and all of them cost money."

The team needs funds and volunteers, or "kick-ass civilians" who are willing to help, so they can continue coming to the aid of people in need across the country and the globe. If you would like to support Team Rubicon, visit teamrubiconusa.org/give. **RB**



HEAR THE DIFFERENCE



2024
**POST-FRAME
BUILDER
SHOW**
BOOTH #
410



Did you know that you can **HEAR THE DIFFERENCE** between the Everlast II® OMNI panel and our competitors' panel? Everlast's panel has both AZM® technology and superior thickness. Not only do you see the difference in quality, but you can hear it, too.

Scan the QR code and take a listen for yourself.

EVERLASTROOFING.COM | 888.339.0059

**Everlast
Roofing, Inc.**
OUR NAME SAYS IT ALL

POST-FRAME BUILDERS SHOW

June 19-20

Shield Wall Media Shows Specialize In Connecting Buyers & Sellers

If your company offers or builds post-frame structures, or you are considering expanding into post-frame buildings, you need to plan to attend the Post-Frame Builder Show in Branson, Missouri, June 19-20.

Produced by Shield Wall Media, the Post-Frame Builder Show offers educational sessions, a robust expo hall filled with post-frame material and service providers, and opportunities to meet one-on-one with construction industry insiders. This family-friendly event is the company's third construction-focused trade show as it joins the Construction Rollforming Show and the Garage, Shed & Carport Builder Show.

The Post-Frame Builder Show, like the other Shield Wall Media shows, is strictly a business-to-business event. Exhibitors can expect attendees to be decision makers for their companies and attendees can expect that exhibitors are dedicated to spending the time needed to help them make their buying decisions. While all industry professionals are welcome, Shield Wall events focus on connecting those who ultimately make business happen on the show floor.

"Many shows try to be everything for everyone and see the number of bodies on the expo floor as success," said Shield Wall



Exhibitors are dedicated to spending the time needed to help attendees make their buying decisions.



The Post-Frame Builder Show will take place at the Branson Convention Center, June 19-20.

Media Publisher and CEO Gary Reichert. "We know our audience and we know what we want to deliver. Our goal is a qualified audience so we can connect exhibitors and the decision-makers who want to do business with them."

WHAT YOU'LL FIND

Shield Wall Media's trade shows span two days, which is shorter than a typical trade show. "We keep it simple and business-oriented," Reichert said. "If you are looking for a supplier, it doesn't take three days. Our exhibit hours are Wednesday and Thursday so you can get in, do business, and still spend your weekend with your family."

Post-Frame Builder Show attendees can expect to find equipment manufacturers, component suppliers, and technology innovators. Some of them — such as Boss Hammer Co. — will be hosting demonstrations in their booths. The scope of exhibitors is limited to only those relevant to the post-frame building industry. Don't expect to find cutlery retailers, timeshare peddlers, or booths selling floor polishers.

SUBSCRIBE NOW!



Shield Wall Media brands are dedicated to serving the information needs of construction professionals.



SUBSCRIBE ONLINE: shieldwallmedia.com/subscribe or fill out & mail form below.

FRAMEBUILDING NEWS

METAL ROOFING MAGAZINE

Rural Builder

Rollforming Magazine

GARAGE, SHED & CARPORT BUILDER

ROOFING ELEMENTS

Metal Builder

FREE 3-YEAR SUBSCRIPTIONS!

1. Please check one or more boxes, sign & date:

I wish to receive: Metal Roofing Garage, Shed & Carport Builder Metal Builder
 Rural Builder Frame Building News Rollforming Roofing Elements

Signature (REQUIRED): _____ Date: _____

Print Name: _____

Company: _____

Address: _____

City/State/Zip: _____

Phone or Email (REQUIRED): _____

Check this box if you wish to receive the email newsletter associated with the magazine subscription(s) above.

2. Choose which title applies:

- President/Vice President
- Principle/Shareholder
- Sales Manager or Rep
- Foreman/Crew Manager
- Engineer/Architect
- Other: _____

3. Describe your business:

- Builder/Contractor
- Dealer/Distributor
- Manufacturer
- Engineer/Architect
- Other: _____

I would like to receive my subscription:
 By Mail
 Digitally

SWM2024

4. Please check all of the types of building or manufacturing you are involved with:

- | | | | |
|---------------------------------------|--------------------------------------|---|---|
| <input type="checkbox"/> Post Frame | <input type="checkbox"/> Residential | <input type="checkbox"/> Metal Roofing | <input type="checkbox"/> Rollforming |
| <input type="checkbox"/> Metal Frame | <input type="checkbox"/> Commercial | <input type="checkbox"/> Trusses/Columns | <input type="checkbox"/> Trim & Flashings |
| <input type="checkbox"/> Fabric | <input type="checkbox"/> Equine | <input type="checkbox"/> Foundations | <input type="checkbox"/> Insulation/ |
| <input type="checkbox"/> Agricultural | <input type="checkbox"/> Roofing | <input type="checkbox"/> Gutters/Snow Retention | <input type="checkbox"/> Moisture Control |



MAIL TO:
 Shield Wall Media
 ATTN: Barb Prill
 PO Box 255, Iola, WI 54945

NEW PRODUCTS

Many exhibitors are debuting new products for post-frame construction at the Branson trade show. Plyco is introducing the new Designer Series program and new Klick-Fit trim system. The Designer Series provides 16 new color options within the heavy duty 20 and thermal break 92 door series. In addition, specific to the 92 series, a new residential look 5068 sidelite door is now available. Many types of glass and hardware selections make the Designer series the next generation of a premium door system. Finally, the Klick-Fit trim system for these doors and Plyco windows is an aluminum two-piece 3 ½” finish J type trim to add a beautiful finish trim to your doors and windows.



See the Auger-Lite Pro in the Bucket Bunker booth.
PHOTO COURTESY OF BUCKET BUNKER.

Bucket Bunker®, which manufactures its product line in Kansas and Indiana, is exhibiting its new Auger-Lite Pro™ (U.S. Patent Pending). It is a load-and-go solution for handling and transporting multiple skid steer attachments. This newest model is specifically designed with the post-frame contractor in mind. The challenge of moving multiple attachments from jobsite to jobsite is simplified by organizing tools and attachments into a single, portable unit. It is designed to manage one hydraulic auger drive head, up to three auger bits, a set of pallet forks, and a single skid steer bucket. Additionally, it can be moved with a bucket as well as standard pallet forks. Every unit is constructed of steel tubing and ¼” plate, and is powder coated for durability.

Levi's Building Components will be showing its new CoVent Exhaust Fan Vent. Ideal for interior exhaust fans equipped with a 3” or 4” flex hose, it is an all-in-one exhaust fan vent designed for metal roofs and intended for bathroom and attic venting.

AJ Manufacturing released two new products in March; they will both be on display at the Post-Frame Builder Show. The company is exhibiting its new insulation dam kit (patent pending). The easily installed kit is made of G-90 Galvanized 24-ga. Steel and is designed to manage up to R-60 of blown cellulose or fiberglass batt insulation. AJ Manufacturing is also showing its



The industry's first patented precast concrete skirt board brought to you by Perma-Column. PHOTO COURTESY OF PERMA-COLUMN



Learn more about the Amarr Northwoods Modern Plank Garage Door at the Delden Garage Doors booth. PHOTO COURTESY OF DELDEN.

new, more energy-efficient ceiling access doors. They feature a self-flashing frame fabricated of commercial-quality painted aluminum extrusions, miter cut corners, and assembled with screws. The 6”-thick door panel is designed to accommodate up to an R-42 insulation thickness, while the 4” thick door panel will accommodate up to R-28. Both are available in single- and bi-fold panel designs.

Perma-Column has devised yet another permanent problem solver for post-frame builders: the industry's first patented precast concrete skirt board that will never rot or warp. The precast skirt boards feature a 4” concrete base secured to wood with stainless-steel shear studs. Non-rusting basalt composite rebar runs the length of the precast concrete for further strength and stability.

Delden Garage Doors is showing off its new Quick-Stock program offering custom-packaged garage doors. They will also

She's Got Your Eyes, and Someday, She'll Inherit Your Roof.

Remarkably Strong. Surprisingly Lightweight. GALVALUME® Steel Sheet.

For projects requiring the strength and durability of steel, and the all-weather corrosion resistance of a zinc and aluminum coating, ask for GALVALUME® steel sheet. SDI's Acrylic and Painted GALVALUME® sheet set the industry standards for residential, commercial, agricultural, and architectural projects. Available in acrylic and a rainbow of paint colors, and in widths up to 72", GALVALUME® steel sheet is ideal for an endless variety of applications, including:

Roofs

- Standing-Seam
- Tuff-Rib
- R-Panel
- Ag Panel

Siding

- Standing-Seam
- Board & Batten
- Box Rib
- All Purpose

Garage Doors

- Roll-Up
- Sectional
- Hinged
- Slide-to-Side

In addition to serving as North America's largest supplier of GALVALUME® steel sheet, every product the SDI Flat Roll Group produces uses up to 80% recycled steel. This makes GALVALUME® sheet a great choice for green building projects. **GALVALUME® is the only aluminum/zinc coating for steel sheet backed by over 70 years of trusted performance.**



Give your next project a proven advantage—ask for GALVALUME® steel sheet by name. Contact your Steel Dynamics representative to learn more.



BUTLER DIVISION
Butler, Indiana

COLUMBUS DIVISION
Columbus, Mississippi

HEARTLAND DIVISION
Terre Haute, Indiana

THE TECHS DIVISION
Pittsburgh, Pennsylvania

SOUTHWEST-SINTON DIVISION
Sinton, Texas

be showing the new Amarr Northwoods door, which features printed horizontal plank designs on a ribbed section that creates depth, texture, and subtle dimension and is “A perfect complement to modern, mid-century modern, and traditional architectural styles.”

Window manufacturer WinTech is displaying its newest premium windows: OzarkView. “WinTech’s OzarkView windows feature fusion welded mainframes and sashes, composite-reinforced interlocking meeting rails, and performance insulated glass. They are suitable for your residential and commercial applications.



Randy Chaffee of Source One Marketing will share his insights on relationship building and sales.

EDUCATIONAL SESSIONS

The Post-Frame Builder Show educational programming emphasizes topics you, as a decision-maker, want to see. Programming focuses on how you can make your business more successful by providing you with the assets you can use to do that. Those assets include connecting attendees with product and service providers, offering insights on best business practices and building efficiencies, and how to reduce costs and increase profit margins. Specific topics include, but are not limited to:

Condensation is a concern for all metal buildings in which the environment is not controlled. To explain why and what can be done about it, Dripstop’s Orion Ewell will lead a session on condensation control. In the business building track, Joel M. Oney, owner of J Money, has spent 25 years in the banking sector. He will lead a session on financing and payment options. Industry veteran Randy Chaffee, Source One Marketing, will be sharing some of the knowledge gained throughout his successful, decades-long career in relationship building and sales. (He will also be doing live podcasts throughout the show). And Shield Wall Media will teach attendees about free editorial opportunities and earned media in its presentation “How To Get Free Press Coverage.” Also on the docket are foundation solutions for different soil compositions and diversifying a product line. (Please note: Topics and presenters are subject to change.)

General admission is \$50. If you have relationships with exhibitors, contact them; they have an unlimited number of FREE guest passes and will gladly provide you with free admission. These passes include educational programming and are good for manufacturers, contractors, support staff, or anyone else.



Dolly Parton’s Stampede Dinner Attraction.



Branson Ferris Wheel.

Shield Wall Media keeps its shows simple and business-oriented. If you are looking for a supplier, it doesn’t take three days. Exhibit hall hours are Wednesday and Thursday so you can get in, do business, and still spend the weekend with your family whether that means heading home to them or bringing them along to this popular family vacation destination. See page 20 for a few ideas about how you can make the most of a trip to Branson.

Shield Wall Media is proud to be a family-focused company. The Post Frame Builder Show welcomes families and has dedicated areas for those with children to take time to rest, regroup, and maybe build a block tower or have a snack.

If you’re looking for new products, business opportunities, or different sources for products you already use, you can’t afford to miss the Post-Frame Builder Show June 19-20 at the Branson Convention Center in Branson, Missouri. If you have any questions about the Show or would like to exhibit, contact Shield Wall Media Director of Events Missy Beyer at 920-216-3007 or missy@shieldwallmedia.com. **RB**

WE'RE ON A ROLL

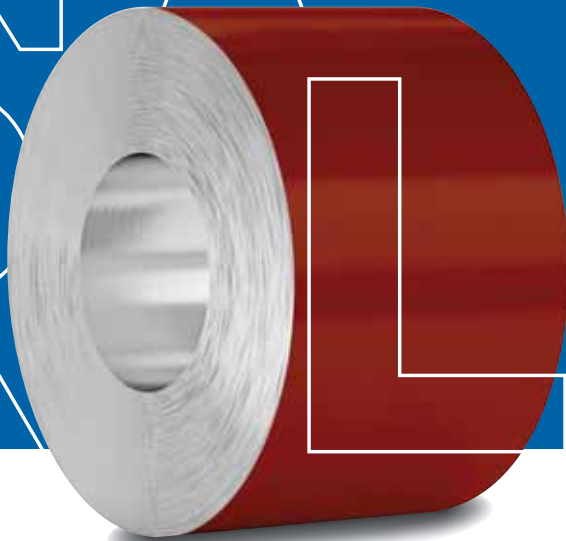

WE SPECIALIZE IN **PAINTED ALUMINUM COIL**

Like our coil, a relationship with Mid South is seamless and catered to your specifications. With over 25 years in the industry, we are painted aluminum coil experts down to our core.

Trust the specialists and let the good times roll.



Alan Sallee Jr
Senior Vice President
731.736.4844

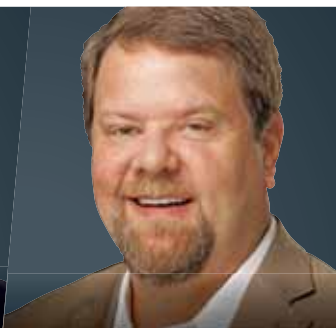

Courtney Friedman
Account Manager
205.292.5697



Steve Swaney
Account Manager
314.757.2733

731.664.2210
midsouthalum.com

MID SOUTH
ALUMINUM

FAMILY FUN IN

BRANSON

MISSOURI!

LET'S EAT!

Farmhouse Restaurant

Good old homestyle chicken, biscuits and gravy, and more...
119 Main St, Branson (Approx. .2 miles from the convention center)

Branson Cafe

Traditional fare is what you'll find here; they have been in operation since 1910 in the historic downtown! Breakfast, sandwiches, chicken, fish, steak, meatloaf, desserts, and more. 120 W. Main Street (Approx. .2 miles from convention center)

Mellow Mushroom (ride the trolley)

This fun pizza place claims to make the best pizza in Branson! They also serve up munchies, greens, calzones and burgers, all in a fun and fantastically themed dining room. Gluten-free and vegan options available. 333 Branson Landing (approximately .8 miles from the convention center)



Paula Deen's Family Kitchen (ride the trolley)

Paula Deen is known for her Southern style menu including fried chicken, pot roast, chicken and dumplings, ribs, with corn on the cob, and mac & cheese among the sides. Kids' portions available. 545 Branson Landing (Approx. .5 miles from convention center.)

Cakes & Cream Café & Drive-In

Enjoy burgers, pizza, ice cream sundaes, and more while watching classic flicks, cartoons and movies at a replica of the old-time drive-in theaters that are no more. Then play mini-golf! 2805 W. 76 Country Boulevard (Approx. 3.5 miles from convention center.)

Mel's Hard Luck Diner

In the style of an old-fashioned diner, you can order chili dogs, burgers, and plate specials, not to mention malts and ice cream. What sets this diner apart is the staff are professional performers who will sing to you while you eat! 2800 West Highway, W 76 Country Boulevard, Branson (Approx. 3.5 miles from the convention center)

Pasghetti's Restaurant & Attraction

Family-style Italian dining in a most fun and unique setting! Themed dining rooms are set in the 1930s in New York. A game room and the

World's Largest Fork and Meatball are some of the highlights. West 76 Country Boulevard (Approx. 3.9 miles from convention center)

• See Branson Boardgame Cafe under What Should We Do?

HOW TO GET AROUND

Branson has very limited public transportation. The good news is that the Free Downtown Trolley, Sparky connects historic downtown Branson with Branson's Landing and the Branson Convention Center. It runs 9am -6pm, 7 days a week.

If you wish to travel beyond Sparky's route, there are car rentals, shuttles and taxis. Here are a few services you could try:

Jerry's Shuttle Service: 417-348-1419

Ride A WayZ Shuttle Service: 417-336-6789

Branson Taxi & Rideshare Concierge Services: 708-0471

WHAT SHOULD WE DO?

Branson Boardgame Café

Technically a restaurant, the big draw is Dozens...no Hundreds of games from classics like Apples to Apples to Mysterium (mystery solving) or even Hungry Hungry Hippos. Sandwiches include the Candy Landwich Meal featuring pb & j. Slushies, coffees, and frappuccinos are available to enjoy between Pictionary sketches. 103 S Business Hwy 65 (Approx. .1 mile from convention center)

Main Street Pops

Ice cream pops you can customize by choosing a flavor, a dip, and a dusting! Dairy-free options available. 110 E. Main Street (Approx. .1 mile from convention center)



Dick's 5 & 10

"it's just like old times!" That's Dick's 5 & 10 tagline. Dick's has unique gifts, one-of-a-kind hobby collections including arrowheads and trains, plus toys from yesteryear, home items, games, hobby supplies, sewing notions, and more. There is something for everyone at Dick's! 103 W. Main Street (Approx. .3 mile from convention center)

Mr. B's Ice Cream Parlor

Serves up old fashioned ice cream and handcrafted sandwiches! 102 S. Business 65, Branson, MO 65616 (Approx. .2 mile from convention center)

Centennial Museum

This is a great place to learn a bit about Branson, the history, culture, and how it became a music hub. Free entrance. 120 S. Commercial Street, Branson (Approx. .2 mile from convention center)

Branson Scenic Railway (ride the trolley)

Climb aboard a vintage passenger train at the historic 1905 depot. Each car



DYNA-GUARD®



DYNA-GUARD® installed



DYNA-GUARD® on duty

S-5! We are discontinuing the line of S-5!® snow retention products. Closeout/below cost prices on S-5!®

- X-Clip™ II **\$2.75**
- X-Gard™ 1.0 Bracket **\$1.85**
- X-Gard 2.0 Bracket **\$4.50**
- S5S Stainless Mini Clamp **19.50**

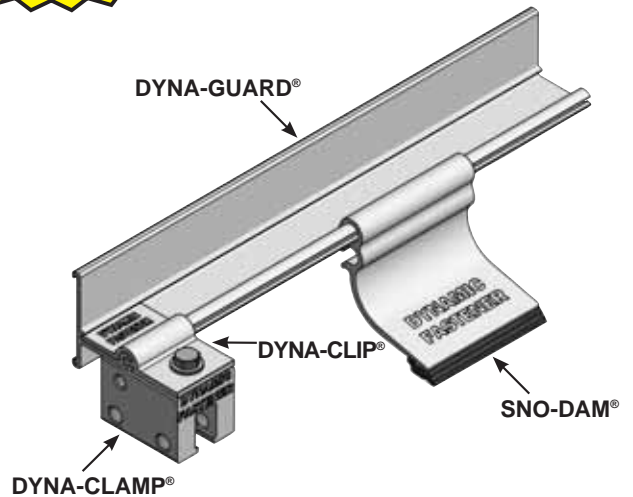

Our Dyna-Guard® Snow Retention System comes with a **free** 30-year warranty. Dyna-Guard®, Dyna-Clamps® & all related various connection points have undergone **extensive third-party testing** by the esteemed Encon Technology - Tulsa, OK

Attention architects / specifiers:

ARCAT For a CSI 3 part specification and CAD details on Dyna-Guard products see our page on Arcat

<https://www.arcat.com/arcatcos/cos50/arc50660.html>



DF ARCAT content

DYNAMIC FASTENER • 800-821-5448

S-5! is a registered trademark & X-Clip, X-Gard are trademarks of Metal Roof Innovations Ltd. DYNA-GUARD, DYNA-CLAMP, DYNA-CLIP, and SNO-DAM are registered trademarks of Dynamic Fastener Service Inc.



is uniquely decorated and the scenery through the foothills of the Ozark Mountains is beautiful! Choose from a 45 minute daytime trip or a dinner excursion. Reservations required. *The intersection of Main Street and Branson Landing Boulevard. 800-2-Train-2, reservations@bransontrain.com*

Queen Esther Biblical Show

This Bible story is brought to life in a spectacular way with live animals, lovely settings, and an inspiring message! *Sight & Sound Theaters, 1001 Shepherd of the Hills Expy (approx. 4.2 miles from convention center)*

The Branson Craft Mall

This mall features crafts and artisans in action, creating their works before your eyes. Artisans include basket weavers, silversmiths, potters, engravers and carvers, plus clothing, bead and stained-glass artists. Custom orders may be available. *694 Historic Highway 165 (Approx. 4.5 miles from convention center)*

NIGHTLIFE IN BRANSON

FINE DINING

Level 2 Steakhouse

This steakhouse boasts world-class service and cocktails. They serve Kansas City 28 day aged Certified Hereford Beef and seafood specialties. The location can't be beat: *Hilton Branson Convention Center Hotel Second Level Concourse.*

Cantina Laredo

All the classics plus a few savory surprises such as shrimp with poblano pepper and fire-charred skirt steak. A full selection of Mexican cocktails with Happy Hour specials from 4-7. *1001 Branson Landing (Approx. .2 miles from convention center)*

Shogun Japanese Steak & Sushi

Enjoy hibachi dinners of steak, chicken, seafood, and more! Or select from a mouthwatering selection of sushi. *3265 Falls Parkway (Approx. 4.7 miles from convention center)*

Chateau on the Lake Resort & Spa

Award-winning cuisine in elegant surroundings can only be topped by the views of Table Rock Lake from the patio. Live piano entertainment accompanies your meal on Friday and Saturday nights. *415 N. State Hwy 265 (Approx. 8.9 miles from convention center)*



Buffalo Bar at Top of the Rock

On the lower level of Osage Restaurant (offering upscale regional cuisine) this pub features a stone patio with breathtaking views of the Ozark Hills. *150 Top of the Rock Road, Ridgedale (Approx. 10.4 miles from convention center)*

PUBS & NIGHTCLUBS

Landshark Bar & Grill

A waterfront restaurant and bar with views of Lake Taneycomo and The Fountains at Branson Landing. Indoor and outdoor seating with fire pits and American beach style offerings including burgers and sandwiches, seafood, and more. *915 Branson Landing (Approx. .2 miles from convention center)*

The Paddlewheel

A low-key good time, the Paddlewheel offers draft brews, cocktails, outdoor seating, fire pits, a big screen TV and, sometimes, live entertainment. *9 S N Boardwalk (Approx. .6 miles from convention center)*

Andy B's Tiki Bar

This Hawaiian style open air bar invites you to mix up your own classic or be adventurous and discover a new one. *433 Promenade Way (Approx. .8 miles from convention center)*

Wranglers Star Studded Honky-Tonk

From classic to modern, this is your place for country music! Live music and dancing from 5pm to 8pm. *625 State Highway 165 (Approx. 4.4 miles from convention center) 417-544-1405, https://wranglershonkytonk.com/*

Crazy Craig's Cheeky Monkey Bar

Looking for a place to party? Crazy Craig's has a live band or DJ nearly every night. Enjoy the dance floor, pool tables (free during happy hour from noon to 6pm Monday through Friday), darts, and electronic games. Barbeque, burgers, and bites served. *120 Montgomery Drive (Approx. 7.3 miles from convention center)*

SHOWS

Legends in Concert

Tributes to various music legends are the entertainment. The lineup is: Elvis, The Beatles, and The Blues Brothers. Shows run every day except Wednesdays. Check the website for tickets. *1600 W Highway 76 Country Blvd (Approx. 2 miles from convention center) legendsinconcert.com*

The Haygoods

Twenty instruments, state-of-the-art sound and special effects, a great sense of humor, and six siblings create a musical show that packs the house every night. *3216 W 76 Country Blvd (Approx. 4 miles from convention center) 1-800-785-1610. RB*



Dinosaur Museum

Life-sized dinosaur replicas and information about their habits will take you back in time! Fossil exhibits, and documentary films deliver more educational fun. There's even a scavenger hunt! 3619 W 76 Country Boulevard (Approx. 5.2 miles from convention center)

World's Largest Toy Museum

From the colonial days to the good old days of your childhood, there are a million toys in this museum! It's a toy-riffic way to spend some time with your kids! 3609 W 76 Country Boulevard (Approx. 5.1 miles from convention center)

BRANSON LANDING FUN (ride the trolley)

Branson Landing Water & Fire Show

You won't want to miss the Fountain Show, a grand display of 120-foot

geysers and fire columns, and lights all set to music. 100 Branson Landing Boulevard

Parakeet Pete's Steampunk Balloon

This truly unique adventure gives the enjoyment of floating away in a balloon without leaving the steel structure in which it is encased. Enjoy beautiful views of Branson and Lake Taneycomo. Visitors of all ages can ride in the balloon, believed to be the only one of its kind in North America. 1113 Branson Landing

Shipwrecked Treasure Museum

This museum gives your kids the fun of a treasure hunt through exhibits, displays and interactive features! You'll see authentic artifacts from historical shipwrecks and more. 505 Branson Landing Boulevard

RB



800-448-8979

tracrite.com • tr@tracrite.com



PERFORMANCE • VALUE • SERVICE

YOUR INDUSTRY LEADING DOOR PROVIDER



GREAT SPRINGS



EXCELLENT WIND RATINGS



EASY TO INSTALL



FAST LEAD TIMES



SCAN to Learn More



OUR ROLL UP DOORS ARE STRONG, SMOOTH, & QUIET

Material Choices in Livestock Buildings to Combat Corrosion

There are no perfect materials, but there are good material choices for each building situation. The interior of a livestock building needs to be hygienic, easy to clean, and durable. This is a really tall order for some parts of the building and presents a big challenge for a manufacturer that wants to make a good product that they can stand behind.

The interiors of livestock buildings are a unique environment

with some serious challenges that require careful material selection. Of particular concern in livestock buildings is corrosion because the inside of a livestock building will be exposed to some very corrosive conditions (salt, acid, and oxidation).

Metals, especially coated metals, can be great building materials in many environments, but they aren't always the best choice when the environment gets acidic, salty, or has a fluctuating redox potential. (An explanation follows if you aren't familiar.) Livestock manure and urine present the trifecta of tough environments for the use of metals, as the urine is acidic and salty and the manure is alive and thus the microbes in it are oxidizing carbon. When they run out of oxygen, they'll use nitrogen, iron, and sulfur instead. These environments can even lead to the formation of hydrogen sulfide, which will oxidize and make sulfuric acid.

While metals are often great building materials, they are susceptible to the action of acids and oxidation that we refer to as corrosion. The corrosion process leads to the deterioration of metals through surface rust, pitting, and eventually the formation of holes. At the heart of it, corrosion is an electrochemical process.

Simply put, electrons are being transferred from one material



PVC Panels for Pig Farms. PHOTO COURTESY OF AGRICLE

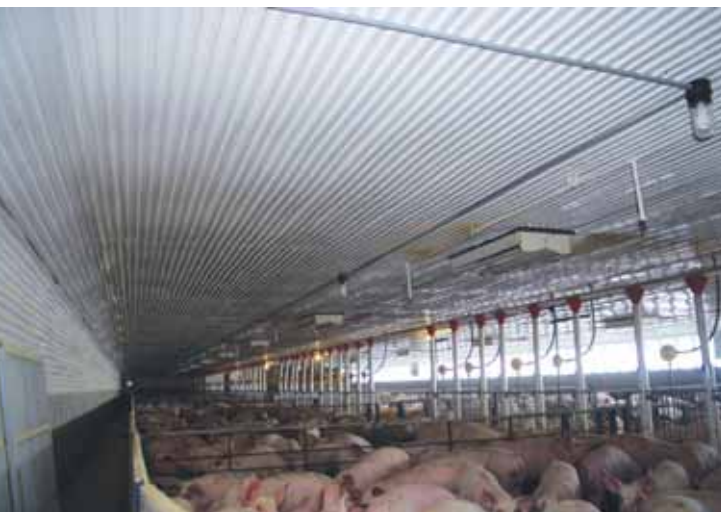

PVC Panels for Pig Farms. PHOTO COURTESY OF AMERILUX

PVC Panel Tips for Agricultural Buildings

According to Buddy Pullen of Amerilux, a common solution when trying to avoid corrosion for agricultural building is PVC panels. They are generally bright white for a clean aspect, although they are available in many colors, and the ease of cleaning the surface makes them safer for humans and animals. Furthermore, if they are installed and maintained correctly, they can last as long as any building.

When installing PVC panels in a climate-controlled room, allow the PVC to acclimate for a few days, just as you would for hardwood flooring.

Be sure to follow manufacturer instructions and provide proper bracing.

If chemicals will be stored in the building, be sure to check the vendor's chemical compatibility list.

All plastic expands and contracts, so keep that in mind during installation, ensuring trims and joists have extra room to accommodate this expansion/contraction. One consequence of not leaving space for expansion can be oil canning (the panel can become wavy in appearance between improperly installed fasteners) when panels get warmer.

Avoid direct sunlight when storing these panels. At minimum, keep an opaque cover over the panels. Do not store them in a closed building without ventilation; high temperatures in these conditions can start to deform PVC panels. The maximum temperature that most PVC can tolerate is around 140 degrees.

www.amerilux.com

to another (the material that loses electrons is getting oxidized and the material accepting the electrons is getting reduced) and then a second chemical reaction is occurring with the new materials. If iron metal is getting oxidized, the iron is likely going to go from an oxidation state of zero (think no charge) to an oxidation state of 2 or 3 (think 2+ or 3+).

In this scenario, the iron is losing 2 or 3 electrons. The iron 2 or 3 (iron 2 is rapidly converted to iron 3 if oxygen is present) that is formed is highly reactive with oxygen and water, resulting in the formation of rust. The presence of acids will increase the amount of oxidation, as acids readily accept electrons, while the metal, in this case iron, is losing them.

Once that rust starts, it grows and keeps on going unless you intervene with removal or chemicals and, even then, it sometimes will continue. The main tool to combat steel corrosion is galvanizing. This is normally all that's needed for a building exterior, but in the case of a livestock building interior, galvanizing is likely to be insufficient. The reason for this is the acidity in animal urine.

Acids like those in urine can often react with metals, particularly iron, aluminum, zinc, and copper. For this reason, metal

panels have a hard and short life if used in certain parts of livestock buildings. The acids in animal urine will slowly eat at the zinc coating, exposing the steel under the galvanized coating and lead to rust through the previously mentioned process.

Aluminum, which can be a great choice for lots of building environments (strong, light, non-corrosive), is considered "non-corrosive" in most situations. But this isn't the case when that environment is a bit different. Normally, aluminum will form an oxide coating on its exterior that is quite stable, which protects the metal from deterioration, but this oxide coating is not durable in an acidic or basic environment. For this reason, aluminum isn't a good choice for some livestock building interior uses.

The acidic environment in and around livestock manure and urine will eventually eat away at aluminum. Aluminum may still have a place in livestock buildings, though, and that's for small-scale low-animal-density structures where the aluminum isn't in contact with manure. Windows in a low-density livestock building would be an example of a setting where aluminum would be a good choice, especially if it is coated or painted.

One could use stainless steel for livestock building interiors

Your Dream Building Starts with the Components.

MWI COMPONENTS TO BE EXACT.



800-360-6467

MWICOMPONENTS.COM

SPENCER, IA



PRODUCT FEATURE

(it would be beautifully shiny!), but that would be at great expense, and even stainless steel can corrode in the challenging conditions of a livestock building interior. Thus, what a customer wanting a livestock building really needs for the interior is something non-corrosive and a bit more cost effective. Since we need tough, durable, easy-to-clean material, but stainless steel is likely too expensive, we will have to look to some other materials for livestock building interiors. This is where materials like PVC and plastics come in, though stainless will still play a role for some fixtures and for fasteners.

Materials such as PVC, coated fiberglass, and various plastics can probably be used successfully in livestock building interiors. While materials like fiberglass, PVC, and other plastics don't corrode, they aren't the best materials for exterior use in many cases.

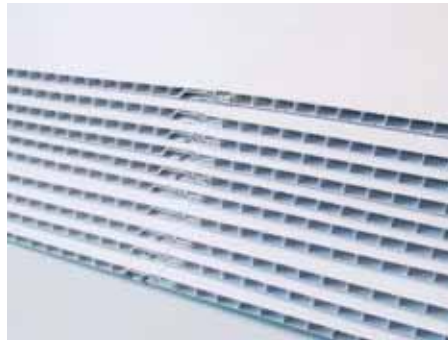

Amerilux Panels



UV light is often a catalyst for the degradation of these materials along with high temperature and mechanical stress. The good news here is that we are going to use these materials inside, so high temperature and UV are much smaller concerns than they would be for exterior use. Mechanical stress still remains an issue for the durability of these non-corrosive material, as livestock are always hard on things, but this would be no different for metal.



Proven Building Solutions.

DAYLIGHTING • WALL AND CEILING CLADDING

PALRAM PRODUCTS

For more than 60 years, Palram's commitment to quality has led to products that are durable and versatile with warranties that ensure your satisfaction!

SUNSKY®

SUNSKY is the leading corrugated polycarbonate product for skylights, sidelights, complete roofs, and cladding. SUNSKY has 20 times greater impact resistance than FRP, plus a lower yellowing index and the highest light transmission.

DURACLAD®

DURACLAD Multiwall Interlocking PVC interior wall & ceiling panels have a tongue-and-groove design allowing for quick installation. Chemical and water resistant. Available in bright white and NEW white shiplap Designer Series.

PALCLAD® PRO

These solid PVC wall cladding panels are a cost-effective alternative to FRP. PALCLAD PRO contains no fiberglass, has a 5-year warranty, and is Class A fire-rated. Also, chemical and water resistant.



To learn more, contact your local distributor or call 800-999-9459. Or visit us at: palram.com/us



So why do materials such as PVC, fiberglass, and plastic not corrode? Well, simply put, these aren't metals and are thus not going to be sensitive to oxidation and reduction reactions in the same way that metals are. The simplest explanation here is that metals are pretty free with electrons, as they allow them to move easily within the material (this is why they are good electrical conductors) while other materials may not.

Generally speaking, materials that aren't good conductors of electricity are good insulators (glass and ceramics would be in this category) and are also less likely to corrode. PVC, fiberglass, and plastics can certainly oxidize, but the conditions required for that to occur require a lot more energy and different conditions compared to metals like iron. Similarly, glass doesn't corrode, but it is probably obvious why a bunch of glass panels aren't used inside a livestock building.

Anyone who has been around animals knows that they sometimes chew on, bite, and even eat things that they shouldn't (I am looking especially at you goats!). With this in mind, it is important to make sure that things that might

Doors on Agricultural Buildings

Panels for animal confinement have to be tough to deal with everything animals can put them through, but doors can be a concern as well. Vicki Wachtendonk of AJ Manufacturing provided this checklist for finding the right door:

- Is this a door through which livestock will pass? If so, corrosion-resistant material is called for.
- Does the door need to be side or top hinged?
- Will internal reinforcements be needed? If hogs, sheep, or larger animals will pass through, you will likely want a reinforced door.
- Will transit guards be needed on the doors? For example, if a passageway is required to move hogs from one pen to another, a door may only open 90 degrees, and a transit guard can protect the door edge as well as the animals.
- Are door lites required?
- Will hardware attachments require reinforcement?
- Consider corrosion resistance of the hardware. Stainless steel is often the corrosion-resistant choice. Stainless steel titanium hinges are superior to plated steel for corrosion resistance.

www.ajdoor.com

Master Flash® Roofing • Plumbing • Electrical • HV/AC • Solar SEAL IT RIGHT, SEAL IT TIGHT®



Low-Profile Master Flash®



Low-Profile Multi Master Flash®



PH: (858) 513-4350 • FAX: (858) 513-4305
info@aztecwasher.com • www.aztecwasher.com

PRODUCT FEATURE

get this sort of treatment from livestock aren't going to harm them if inadvertently ingested. While none of the materials mentioned (PVC, fiberglass, plastics) are advisable to ingest, they have been used in and around food and water for human and animal use for quite some time. But since you wouldn't eat them, it is probably wise to use the least potentially toxic where it might get chewed and others in places where that isn't as likely. Additionally, for the purposes of durability, it may be advisable to construct things in a way that minimizes or reduces access for chewing and biting these materials.

Quick thoughts here are that PVC and fiberglass would be great for windows. If windows are up and away from urine and manure, then aluminum frames can work well and may be cheaper and lighter than other options. PVC and fiberglass could also work well for doors. Stainless could be used here if the added strength and durability justify the expense. PVC and fiberglass can also be used for wall panels.

Plastics might make the most sense as dividers and panels amongst the livestock (maybe with stainless tubing around the

edges to deter the animals from chewing on them). Putting plastics where the animals might chew on them is probably OK, as many of these are the same types of plastic that we use for cutting boards and milk jugs; in other words, they are food safe. Plastics such as high density polyethylene (HDPE) are also more impact resistant than PVC (but also more expensive), so these may make the most sense for dividers.

One last consideration is that the corrosive environment in livestock buildings is not limited to the contact with manure and urine. The ventilation system is likely to encounter issues with corrosion as well. Some of the gases that will be vented (ammonia and potentially hydrogen sulfide) can react with moisture to create acids and then, when neutralized by reacting with surfaces, create salts, leading to corrosion in and around ventilation (whether passive vents or fans). Paying attention to these areas is important as well. Consistent removal of manure and urine, or consistent use of bedding, or both, can help reduce the formation and release of these gases and ensure the longevity of all parts of a livestock building. **RB**

These are no ordinary post frame screws

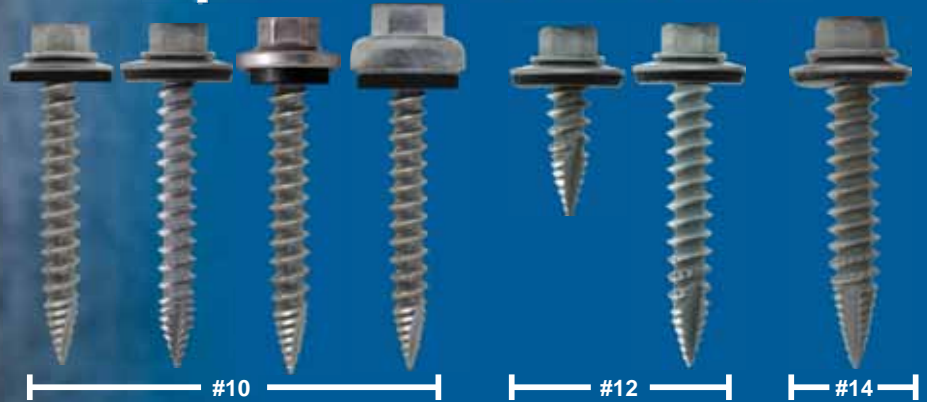

- Low-angle thread help from over-driving the washer and increases resistance to back-out
- #10, #12, #14 | Steel with TRI-SEAL | Stainless Steel ZAC Zinc Cap Head | Stainless Cap Head
- Patented BURR-BUSTER® Point reduces burrs caused during piercing of the steel



Checkout the performance versus ordinary screws!

TFC
TRIANGLE FASTENER CORPORATION
www.trianglefastener.com
800.486.1832



Call for free samples!

We make connections better!

2024 POST-FRAME BUILDER SHOW

Branson, MO • June 19-20, 2024



931-589-2386
www.buffalorivertruss.com

BOOTH #720

RICHLAND
LAMINATED COLUMNS LLC

419-895-0036
twilson@richlandcolumns.com

BOOTH #320



Roofing Ventilation & Accessories

800-800-8590
www.marcoindustries.com

BOOTH #416



800-448-8979
www.tracrite.com

BOOTH #313



888-752-7552
www.speedlap.com

BOOTH #711



330-674-4003
www.acuformequipment.com

BOOTH #407



417-235-7821
www.wintechinc.com

BOOTH #716



800-622-7190
www.permacolumn.com

BOOTH #209



708-482-1800
http://thlemont.com

BOOTH #817



717-572-0910
www.standingseamroofvent.com

BOOTH #703



800-932-8371
www.weavertoolgear.com

BOOTH #523



573-569-4800
www.frontiermetal.biz

BOOTH #801



800-522-2426
www.footingpad.com

BOOTH #314



www.diamondbuildingsupply.com

BOOTH #819



www.malcotools.com

BOOTH #621



800-788-1050
www.ViWintech.com

BOOTH #520



715-644-0765
www.hixwood.com

BOOTH #109



888-308-7858
www.wildcatcompany.com

BOOTH #507

2024 POST-FRAME BUILDER SHOW

Branson, MO • June 19-20, 2024

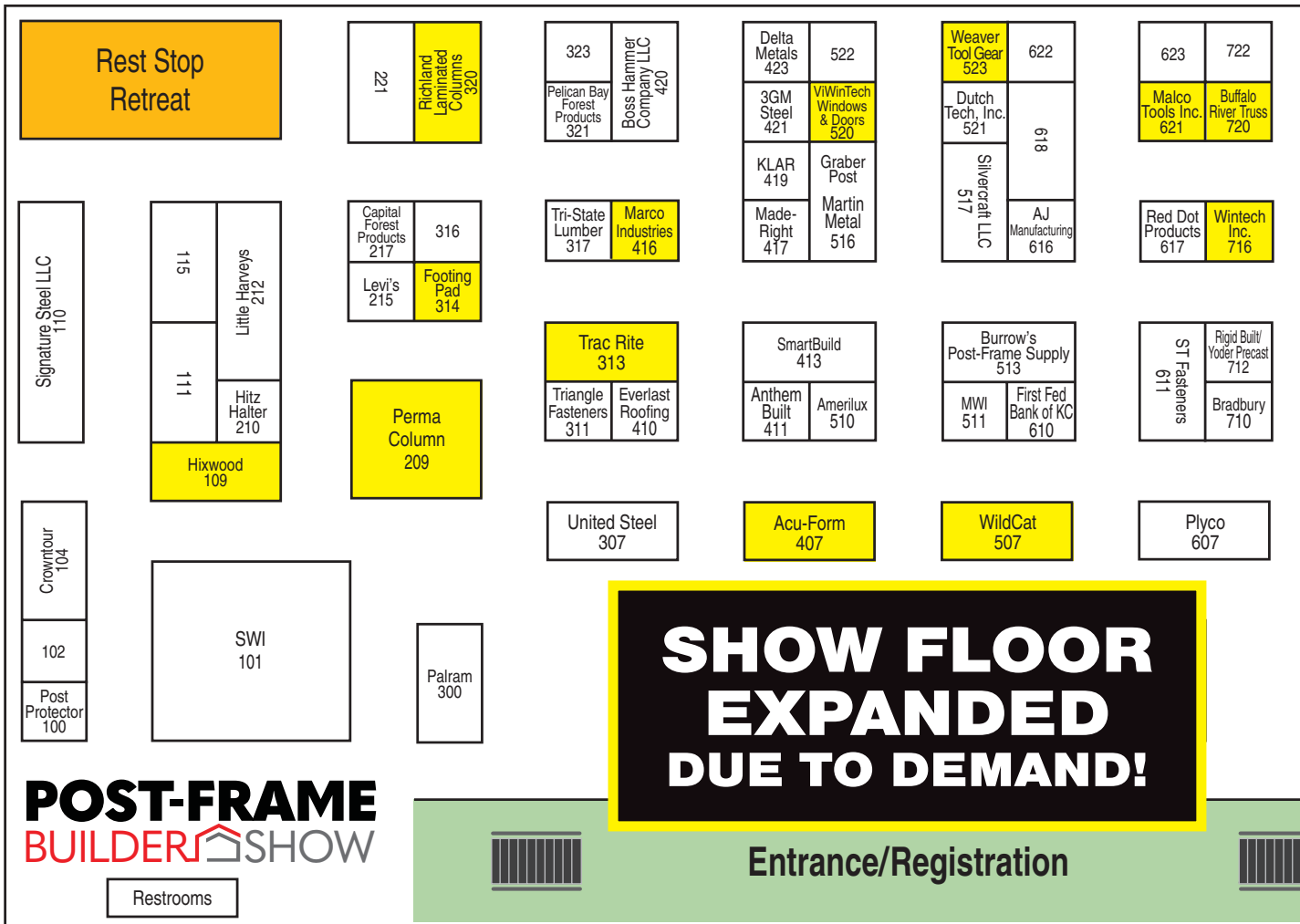

POST-FRAME BUILDER SHOW

KEEP UP TO DATE BY VISITING: www.framebuildingnews.com/postframe-builder-show-registration

Exhibitors are also subject to change due to unforeseen circumstances.



BOOTH # 720

RICHLAND
LAMINATED COLUMNS LLC

BOOTH # 320



Roofing Ventilation & Accessories

BOOTH # 416



BOOTH # 313



BOOTH # 523



BOOTH # 407



BOOTH # 703



BOOTH # 711



BOOTH # 314

SHOW HOURS

Wednesday, June 19, 2024
Education Classes: 9:00am to 4:00pm
Exhibit Hall Hours: 11:30 to 5:30pm

Thursday, June 20, 2024
Education Classes: 8:00 to 11:00am
Exhibit Hall Hours: 8:30am to 12:30pm

EXHIBITORS

Company Name	Booth #	Company Name	Booth #
3GM Steel Inc.....	421	Malco Tools	621
Acu-Form	407	Marco Industries	416
AJ Manufacturing, Inc.....	616	Martin Metal	516
AmeriLux International.....	510	MIDCO Building Products.....	713
Anthem Built	411	MWI Components.....	511
Boss Hammer Co. LLC.....	420	Palram Americas	300
Bradbury Group.....	710	Pelican Bay Forest Products.....	321
Bucket Bunker	701	Perma-Column LLC.....	209
Buffalo River Truss LLC.....	720	Plyco Corporation	607
Burrow's Complete Post-Frame Supply.....	513	Post Protector	100
Capital Forest Products	217	Red Dot Products, LLC.....	617
Capital Truss and Lumber.....	110	Richland Laminated Columns.....	320
Crowntour	104	Rigid Built Laminated Columns	712
Delden Garage Doors.....	812	Signature Steel, LLC.....	110
Delta Metals.....	423	Silvercraft LLC	517
Diamond Building Supply	819	SmartBuild Systems	413
Dripstop®.....	707	Snap Z.....	703
Dutch Tech Inc.....	521	SpeedLap LLC.....	711
Everlast Roofing, Inc.....	410	ST Fastening Systems.....	611
First Federal Bank of Kansas City	610	Strong Wall Columns.....	717
Footing Pad	314	SWI Machinery	101
Forest Products Supply Co.....	811	T&H Lemont	817
Frontier Metal LLC	801	Trac-Rite Door	313
Graber Post Buildings, Inc.....	516	Tri State Lumber	317
Hitz Halter.....	210	Triangle Fastener Corporation	311
Hixwood.....	109	United Steel Supply	307
J Money LLC.....	800	ViWinTech Windows & Doors	520
Klar USA	419	Weaver Tool Gear.....	523
Levi's Building Components	215	Wildcat LLC	507
Little Harveys.....	212	Wintech Inc.....	716
Made Rite Metal Buildings.....	417	Yoder Precast.....	712

723	822	Diamond Building Supply 819
721	820	
Strong Wall Columns 717		T&H Lemont 817
Midco Products 713	814	Forest Products Supply Co. 811
SpeedLap 711	Delden Garage Doors 812	
Dripstop® 707		807
Snap Z 703	802	Frontier Metal 801
Bucket Bunker 701	J Money, LLC 800	
Restrooms		



BOOTH # 520



T&H LEMONT
 An Inductotherm Group Company

BOOTH # 817



BOOTH # 621



BOOTH # 801



BOOTH # 819



BOOTH # 209



BOOTH # 716



BOOTH # 109



BOOTH # 507

THANK YOU

2024 POST-FRAME BUILDER SHOW SUPPORTERS



BOOTH #407



BURROWS
COMPLETE POST-FRAME SOLUTIONS

BOOTH #513



T&H LEMONT

An Industream Group Company
BOOTH #817



BOOTH #507



BOOTH #621



BOOTH #616



**BRADBURY
GROUP**
BOOTH #710



**Everlast
Roofing, Inc.**
OUR NAME SAYS IT ALL
BOOTH #410



BOOTH #101



BOOTH #611



CORPORATION
BOOTH #607



BOOTH #215



**MARCO
INDUSTRIES**
Roofing Ventilation & Accessories
BOOTH #416



BOOTH #421



**smartbuild
systems**
BOOTH #413



BOOTH #212



**PERMA
COLUMN**
BOOTH #209



BOOTH #109



BOOTH #100



BOOTH #711



BOOTH #320



BOOTH #311



BOOTH #314



BOOTH #801



BOOTH #313

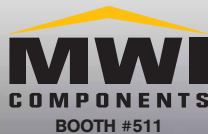

BOOTH #511



BOOTH #707



**UNITED
STEEL SUPPLY**
BOOTH #307



BOOTH #516

VISIT THEM IN BRANSON!



**POST-FRAME
BUILDER SHOW**

www.framebuildingnews.com



3GM Steel Inc.

Booth #421

1650 W. Hwy. 80
Somerset, KY 42503
606-676-2146
606-676-0012 (fax)
sales@3gmsteel.com
www.3gmsteel.com

3GM Steel is a family-owned, American steel trading and coil distribution company. Since 1989, we've focused on providing the highest quality product available, at competitive prices, delivered with professional service. 3GM Steel warehouses and distributes bare, acrylic-coated, and pre-painted Galvalume® to roll formers nationwide. We also leverage our relationships with tier-one mills across the globe to offer our partners custom-tailored steel solutions. The 3GM Steel team is comprised of seasoned steel industry veterans and professional support staff, and partners with customers to help drive their growth plans.



Acu-Form

Booth #407

10550 Township Road 262
Millersburg, OH 44654
330-674-4003
330-674-4035 (fax)
wayne@acu-form.com
www.acuformequipment.com

Acu-Form has been the trusted name for premium roll-forming machines in the steel roofing industry. Our unwavering commitment to tried-and-true manufacturing processes, founded on proven design principles and strict quality control checks, sets the foundation for the Acu-Form promise – quality, reliability, and longevity. When you choose Acu-Form, you're choosing a partner dedicated to your success.



AJ Manufacturing, Inc.

Booth #616

1217 Oak St.
Bloomer, WI 54724
800-328-9448
715-568-3099 (fax)
vwachtendonk@ajdoor.com
www.ajdoor.com

A.J. Manufacturing builds high quality pre-painted or stainless steel walk doors. All doors are pre-hung in steel, aluminum or stainless steel frames with 4" x 4.5" fixed pin hinges for 4-way universal swing even with a foamed in place door lite. A.J. also offers a complete line of high quality vinyl windows. Options include horizontal sliding, fixed lite, casement, single hung, and double hung windows with the patented EZ-v™ vinyl trim and flashing system.



AmeriLux International

Booth #510

1300 Enterprise Drive
De Pere, WI 54115
920-336-9300
920-337-9301 (fax)
info@amerilux.com
www.amerilux.com

AmeriLux International is a value-adding distributor and fabricator of building materials and plastic sheets. Our product offering includes: CoverLite® polycarbonate corrugated panels are perfect for skylight and sidelites. Agrilite™ PVC corrugated liner panels are durable and easy to install. Abuse and moisture resistant, EZ Liner™ is a low-maintenance PVC interlocking liner panel. EZ Slatwall is a versatile

wall organizations system. EZ Forms® concrete wall system assembles easily because the forms and spacers snap together horizontally.



ANTHEM BUILT

Booth #411

305 Pine Street
Varna, IL 61375
309-463-2777
info@anthembuilt.com
www.anthembuilt.com

Anthem Built is a manufacturer of innovative post frame products. Our column repair methods and products provide opportunities for builders and solutions for building owners. At Anthem Built, our focus is solving problems with great products. Foundation repair & replacement, purlin attachment, specialized tools, and more.



Boss Hammer Company LLC

Booth #420

5015 Mertz Rd.
Mayville, MI 48744
info@bosshammerco.com
www.bosshammerco.com

Boss Hammer Co. is a Michigan based family owned and operated company. It is the first ever premium performance framing hammer of its kind. Our hammers can square a 90, measure degree and common cut marks, has a stick rule and magnetic nail starter. The Pro Plus models include side nail pullers, an integrated socket (13mm) and a tether hole in the bottom of the handle.



BRADBURY GROUP

Bradbury Group

Booth #710

1200 E Cole
Moundridge, KS 67107
620-345-6394
bradbury@bradburygroup.com
www.bradburygroup.com

Bradbury manufactures a wide range of equipment for the metal building, roofing, and post frame industries including in-plant and portable roll formers, integrated felt wicking applicators, trim folders, CTL/Slitter lines, fully automated trim lines, and related coil-processing equipment. All Bradbury machines are engineered for easy operation and durability.

BUCKET BUNKER

LOAD & GO ATTACHMENT RACKS

Bucket Bunker

Booth #701

Ottawa, KS 66067
800-522-9160
sales@bucketbunker.com
www.bucketbunker.com

This game-changing tool will keep all your attachments organized and easily accessible, giving you more time to focus on your work and boost your efficiency. Select from 10 model variations, providing an array of attachment solutions for full-size, mini-skid, and mini-excavator machines. Designed to optimize your equipment attachment storage you can easily transport all your essential attachments in one compact unit. Made in the USA. Order yours today, FREE SHIPPING!



Buffalo River Truss LLC

Booth #720

201 Rose St.
Lobelville, TN 37097
931-589-2386
Monroe@buffalorivertruss.com
www.buffalorivertruss.com

Buffalo River Truss was established in 2014 by two brothers, Mahlon and Monroe Miller. The company's main focus is steel trusses that are built for hay barns, horse barns, shops etc. The great thing about steel trusses is they give you plenty of ceiling room along with durability that will last a lifetime. They also build steel stall fronts, steel frames for horse barns and open run in shelters.



BURROW'S
COMPLETE POST-FRAME SOLUTIONS

Burrow's Complete Post-Frame Supply

Booth #513

101 Leaning Tree Rd.
Ft. Gibson, OK 74434
800-766-5793
info@burrows-supply.com
www.burrows-supply.com

Burrow's is more than a leading supplier of post-frame building materials. In addition to complete building packages, we provide value-added support services that enable builders to efficiently grow their business. Our team supports you from start to finish, offering personal customer service, design assistance, building material insights, in-house manufacturing of wood trusses, metal roofing, siding and trim. We are your partner for complete post-frame solutions.



Capital Forest Products

Booth #217

222 Severn Ave
Bldg 14, Suite 100
Annapolis, MD 21403
410-280-6102
410-280-6108 (fax)
info@capitalforest.com
www.capitalforest.com

For over 40 years, Capital Forest Products has been leading the distribution of lumber and manufacturing materials for the building industry along the east coast. Exclusive relationships with our European and Canadian sawmills allows us to deliver high-quality, premium products to you in full or mixed loads. Supplying exceptional furring strips, framing lumber, panel products, and specialties to industry leaders allows us to be the prime resource that positions you leaps ahead of the competition.



Capital Truss and Lumber

Booth #110

3524 State Hwy 45
Hindsville, AR 72738
479-351-0022
info@capitaltruss.com
www.capitaltruss.com

Capital Truss and Lumber is a locally owned and operated one-stop shop for post-frame buildings and truss manufacturing in Northwest Arkansas. Founded with a desire to be a trustworthy construction partner of contractors and homeowners, our goal is to be the premier provider of trusses and building packages in Northwest Arkansas and surrounding regions.



Crowntour

Booth #104

1245 S 250 W
LaGrange, IN 46761
260-463-5001
260-463-5004 (fax)

Crowntour is a supplier of coils, trims, and metal roofing accessories for the hidden fastener market, offering 29 colors in 26 gauge, grade 50 including textured, smooth and woodgrain patterns coated with AkzoNobel Ceram-a-Star 1050 paint system. We offer custom width and job lot slit coils as well as complete trim packages.



Delden Garage Doors

Booth #812

3530 N Kimball Drive
Kansas City, MO 64161
816-413-1600
816-413-1699 (fax)
sales@deldenmfg.com
www.deldenmfg.com

Delden Manufacturing Company, or more commonly referred to as Delden Garage Doors, is a wholesale garage door manufacturer and distributor. Delden is known for their "Experience the Quality" reputation, multi-line garage door distribution and custom garage

door manufacturing. Delden supplies North America with garage doors, electric openers, parts and accessories through four Missouri door centers: Kansas City, St. Louis, Springfield and Central MO.

5th ANNUAL
Construction Rollforming Show
SEPTEMBER 18-19, 2024
DeVos Place, Grand Rapids, MI

FOR MORE INFORMATION CONTACT MISSY BEYER:
missy@shieldwallmedia.com
920-216-3007

Call Today for Nearest Distributor, Wholesale Only

RICHLAND

LAMINATED COLUMNS LLC
"Your One Stop Pole Shop"

Thank you for your business!



- Manufacturer of Quality Glulam Poles, Nail-Lam Poles, Perma-Columns and GreenPost Polyethylene Wrapped Poles.
- Distributor of Sturdi-Wall Brackets, Post Protectors and The Footing Pad.
- 3-Ply, 4-Ply, 2x6, 2x8 • 100% Treated or Non Treated and Larger Size Poles Available
- Superior Treatment • #1SYP Lumber • 30% Stronger than 6x6 solid

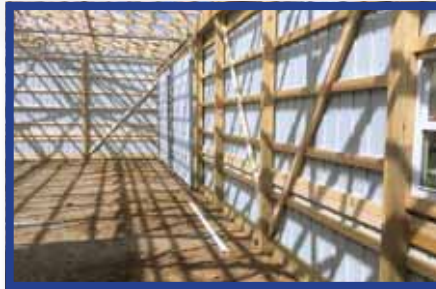

We are now manufacturing the Green Post!



8252 Greenwich, Ohio 44837
Phone: 419-895-0036
Fax: 419-895-0062





Delta Metals

Booth #423

420 Spruce Drive
Lamoni, IA 50140
Chad McDole 641-446-4198
www.deltametals.com

Delta Metals sets the standard for custom manufactured metal roofing, siding, and building packages. We are committed to providing quality products and excellent service that our customers expect. Our products are manufactured to protect the time and money you have invested in your home or business, and in a time of rising energy costs, metal roofing and siding is the ideal choice for your business or home.



Diamond Building Supply

Booth #819

13273 South Highway 63
Clark, MO 65243
www.diamondbuildingsupply.com

Diamond Building Supply, located in Clark, MO, prides itself as a premier destination for quality building materials. Serving contractors, farmers, ranchers, and DIY enthusiasts, our expansive inventory spans over 40,000 square feet to cater to a wide range of construction needs. Since 2020, we've provided the Moberly and surrounding communities with top-notch lumber, plumbing, and electrical supplies, emphasizing affordability and reliability. Our selection from trusted brands ensures your projects are built to last. Visit us for a comprehensive list solution to all your building supply requirements. For more detailed information, please visit our website.



Freudenberg Performance Materials LP

Booth #707

3500 Industrial Dr.
Durham, NC 27704
503-871-5806
info@dripstop.com
www.dripstop.com

For over 25 years, Dripstop® has been the absolute best way of dealing with condensation on non-insulated metal roofs. It has been tried and tested in every climate condition across the globe and has proven to be a simpler and more economical way. The membrane will absorb the water caused by condensation, thus preventing dripping from the roof. Dripstop® serves as an added layer of protection for the metal in corrosive environments while also improving inside and outside acoustic properties.



Dutch Tech, Inc.

Booth #521

107 Third Ave E
Lobelville, TN 37097
931-325-0000
office@dutchtechindustries.com
www.dutchtechindustries.com

We are proud to be an American owned and operated manufacturer located in Tennessee. Dutch Tech's Therma-Guard is America's new favorite reflective thermal insulation. With a super strong, woven backing, that's nearly impossible to tear, Therma-Guard's premium strength sets it apart from the competition. A 3mm foam core gives it thermal resistance to insulate your building, while the reflective metallized face reflects radiant heat, keeping your building comfortable in the summer and the winter.



Everlast Roofing, Inc.

Booth #410

10 Enterprise Court
Lebanon, PA 17042
888-339-0059
717-270-6569 (fax)
marketing@everlastroofing.com
www.everlastroofing.com

For more than 20 years, Everlast Roofing, Inc. has continued to push the metal building component industry forward, leading to the creation and introduction of CECL® and Heat Forming. Understanding how essential quality roofing and siding is to your structure, Everlast shapes their steel roofing with laboratory-tested technologies such as AZM® with Activate Technology. These technologies allow for a self-sealing, protective barrier in the most vulnerable spots, such as scratches and cut edges, while providing a superior paint system tested in some of the harshest regions and formulated against the weather. It is easy to see why Everlast Roofing, Inc. continues to be the most innovative on the market.



First Federal Bank of Kansas City

Booth #610

11550 Ash Street
Leawood, KS 66211
417-317-7728
dave.navrat@ffbkc.com
www.ffbkc.com/barndo

First Federal Bank of Kansas City offers nationwide barndominium construction lending in all 48 continental states. The

loan can include land purchase, complete build of home, land improvements such as water well, septic system, driveway, clearing property, fence, etc. First Federal Bank of Kansas City is an Equal Housing Lender and Member FDIC.



FootingPad Post Footings

Booth #314

400 Carol Ann Lane
Ossian, IN 46777
800-522-2426

customerservice@footingpad.com
www.footingpad.com

FootingPad post foundations are the only tested and certified code compliant footings for use below grade to support

posts and columns. Easy to transport and use, FootingPad saves valuable time and increases profits. FootingPad can be used under wood posts, laminated columns, PermaColumn and concrete piers. Sizing charts are available on footingpad.com to ensure you have the right FootingPad to support your building. Load capacity up to 9,327 lbs per footing.



Forest Products Supply Co.

Booth #811

9264 Manchester Road
St. Louis, MO 63144
314-691-6195

314-961-3509 (fax)
www.fp-supply.com

Forest Products is a family owned and operated wholesale distributor based in St. Louis, MO. We specialize in sourcing and selling the absolute best building materials available in the world. We continually innovate to bring solutions to the market that make projects easier to use, faster to install, and improve overall project aesthetics. We have sawdust in our veins and we're committed to our craft.



UPLIFT PLATE™



SAVE TIME AND MONEY WITH UPLIFT PLATE!

JUST THREE EASY STEPS!

Call (877) 660-3458 to request a sample or for any additional information!



FRAMEBUILDING NEWS

Frame Building News

PO Box 255
Iola, WI 54945
715-252-6360 (Gary)
715-513-6767 (Karen, editor)
karen@shieldwallmedia.com
www.framebuildingnews.com

Frame Building News has been devoted exclusively to coverage of the post-frame construction industry for over the past 35 years. It has more than 21,000 subscribers, most of which make their living in the post-frame industry. It is published five times a year.



Frontier Metal LLC

Booth #801
13737 Hwy 52
Versailles, MO 65084
573-569-4800
573-569-4801 (fax)
www.frontiermetal.biz

Frontier Metal LLC is a full-scale lumberyard and seller of quality metal and trim for any metal roofing or building material needs. Our business also provides building supplies, such as decking, windows, and insulation to name a few. Frontier Metal LLC also offers building packages and has a list of reputable contractors and builders ready to provide reliable work. Our business also provides the option of delivery for materials.



Garage, Shed & Carport Builder Show

PO Box 255
Iola, WI 54945
920-216-3007 - Missy Beyer
missy@shieldwallmedia.com
www.garageshedcarportbuilder.com

The Garage, Shed & Carport Builder Show takes place January 15-16, 2025 in Greenville, South Carolina. This show is all about meeting the business, material and technology needs of those who build small, special-purpose residential structures. Whether an add-on or a free-standing building, small buildings face unique design challenges. If you are looking for best practices or products catering to this niche, you should be in Greenville for the show.



Graber Post Buildings, Inc.

Booth #516
7716 N 900 E
Montgomery, IN 47558
800-264-5013
info@graberpost.com
www.graberpost.com

Graber Post Buildings is a leading distributor and manufacturer of post-frame and metal roofing supplies and materials. We roll-form 6 different metal panels, and we have a custom trim department that can produce almost any trim profile needed for your projects. We also produce nail-laminated col-

umns and pre-engineered wood trusses up to 100' clear span. We also stock overhead doors, windows, sliding door components, cupolas, fasteners, underlayments, vapor barriers, insulation, and much more. A true 1-stop shop!



Hitz Halter

Booth #210
1020 Old State Road
Mattoon, IL 61938
www.hitzhalter.com

Hitz Halter is Innovation in Insulation. We provide high quality EPS foam board for under slab application. We are actively looking for individuals and businesses to stock our products so that we can continue expanding our footprint across the United States and Canada. We offer a number of advantages including a 24 foot fan fold layout, a 6 mil poly film layer attached to the board, and a 6 inch by 6 inch grid pattern for radiant heating. If you are a contractor or if you sell to contractors, our products would be a great new profit center!



Hixwood

Booth #109
N14685 Copenhaver Ave.
Stanley, WI 54768
715-644-0765
715-644-0994 (fax)
www.hixwood.com

Hixwood is the premier source for all your coil, blank flat stock, and slit coil needs. We specialize in supplying the industry with products that are at the top of the spectrum. We have been serving the Roll-Forming and Post Frame industry since 1998.



J Money, LLC

Booth #800

info@jmoneyllc.com
Jmoneyllc.com

J Money is making craftsmanship affordable for home improvement contractors and portable building manufacturers. Connect with us to discover how you can offer financing to your customers for your projects. By working together

with craftsmen, local builders, and their dealer networks, J Money offers a wide range of financing options for their customers.



klar

Klar USA

Booth #419

sales@klar.us.com
www.klar.us.com

Manufacturer of Rigid PVC panels for Ag building applications. Klar uses the most advanced co-extrusion Multilayer technology, which provides excellent resistance to impact and thermo-acoustic insulation properties. Our panels were

designed to resist high levels of corrosion from chemicals, humidity, and micro-biologicals, so they will never rust or rot. Ideal for animal confinements, farms and barns (livestock, poultry, hogs, etc), garages, carwash facilities, storage units (hay, fertilizers, machinery), sheds, shelters, chicken coops and similar.

2025

GARAGE • SHED • CARPORT

BUILDER SHOW

GREENVILLE,
SOUTH CAROLINA

JANUARY 15-16, 2025



Panel Rollformers
Titan, Signature & Patriot

Trim Rollformers
Single & Multi Profiles

Slitting Lines
Stand Alone, Cut to Length, & Slit to Recoil

Decoilers, Upenders, Shears
and much more!

Industry Leading Quality
Unrivalled Service

888.284.6794 | www.mrsrollform.com
info@mrsrollform.com
4511 N Freya St. | Spokane, WA 99217





Levi's Building Components

Booth #215

400 Burkholder Drive
Ephrata, PA 17522
877-897-7020
info@levisbuildingcomponents.com
www.levisbuildingcomponents.com

Renowned for delivering top-tier products, expedited shipping, and meticulous order fulfillment, Levi's Building Components stands as a premier wholesale supplier, offering a comprehensive solution for all your metal roofing requirements. Explore our diverse range of fasteners, including Fast-Grip, MetalGrip, ProCap and ProZ. Additionally, discover our extensive selection of snow retention guards from our Snow Defender line, available in over 40 colors. Uncover an array of roofing accessories, including roofing underlayment, venting solutions, sealants, and more, featuring our exclusive Fastvent Plus, Flovent, and Roloshield lines. For added convenience, access our website, and utilize our user-friendly Snow Defender Calculator, optimized for mobile devices.



Little Harveys

Booth #212

4708 Hunting Creek Church Rd.
Hamptonville, NC 27020
Contact: Jesse Schlabach
800-202-8831
336-468-4309 (fax)
4309@emailbyfax.com

Little Harveys is a distributor of specialty steel coils.

Made Right Metal Buildings

Made Right Metal Buildings

Booth #417

1199 County Road 9
Vernon, AL 35592
205-695-0433 (fax)
www.maderightbuildings.com

Made Right Metal Buildings designs and manufactures quality metal sheds and post frame buildings for a multitude of uses including agricultural, garages, sheds, and barndominiums. We offer full building packages as well as building kits. All projects come with top-tier customer service and competitive lead times.



Malco Tools, Inc.

Booth #621

14080 Hwy. 55
Annandale, MN 55302
www.malcotools.com

Malco Tools, Inc. is one of the nation's leading solution developers and manufactures of a variety of high-quality specialty hand tools for the building and construction trades. Backed by over 70 years of history, Malco offers hundreds of tool innovations for trade professionals. Headquartered Minnesota, Malco manufactures tools that are built to last, rigorously tested and backed by a lifetime warranty.



Roofing Ventilation & Accessories

Marco Industries

Booth #416

4150 S 100th E Ave., Ste. 301
Tulsa, OK 74146
800-800-8590
918-622-4536
info@marcoindustries.com
www.marcoindustries.com

If It's Not Proven, It's Not Marco. We make the best roofing ventilation and accessories—period. With the most tested and certified products on the market, you can trust our solutions to perform in even the harshest conditions, protecting your roof and everything underneath.



Martin Metal

Booth #516

18151 Highway K
Versailles, MO 65084
573-378-4050
573-378-6320 (fax)
www.martinmetal.com

For everything stud frame or post frame buildings choose Martin Metal for quality you can count on, from a company you can trust.





MIDCO Building Products

Booth #713

1040 Dick Castleman Bypass
 Mayfield, KY 42066
 270-247-7447
 270-247-4963 (fax)
 jburnett@midcoproducts.com
 www.midcoproducts.com

MIDCO is proud to be the nation's leading manufacturer of pre-hung doors designed specifically for the shed building industry to accommodate a variety of wall heights. We are also a leading distributor of windows, hardware, roll-up doors, aluminum products, etc. With an extensive LTL program, and our own fleet of trucks, MIDCO can now deliver anywhere in North America, while striving to provide the best service for the shed, carport and post frame industry. For a full list of products we offer, please contact us for a catalog.



MWI Components

Booth #511

1015 32nd Ave W
 Spencer, IA 51301
 800-360-6467
 800-361-3452 (fax)
 www.mwicomponents.com

MWI is the leading manufacturer/supplier of post frame products. With 100+ steel colors, almost 30 aluminum colors, and 50+ powder coat colors, the combinations are endless! Create beautiful buildings with MWI's Arcadian & Dutch Doors, Horse Stalls, Soffit & Trim Systems, Hardware, Square/Round Track, Cupolas, Weather-vanes, Ridge Ventilation, Infinity Shield, Sealants & Retrofit products, and the newest product addition - Pipe Boots! Call MWI Components today at 800-360-6467 to make your building stand out from the rest!



Palram Americas

Booth #300

9735 Commerce Circle
 Kutztown, PA 19530
 800-999-9459
 contactus.usa@palram.com
 www.palram.com/us

Palram is a leading manufacturer of PVC and polycarbonate panels. Palram's SUNSKY® polycarbonate corrugated panels are the leading daylighting solution for skylight, sidelight and roofing. Easily incorporate natural light into your project with SUNSKY for

reduced energy costs. With the world's largest selection of corrugated profiles, SUNSKY matches virtually any metal profile, or custom match using our MetalMatch technology. Palram also offers chemical and moisture resistant PVC panels; AG-TUF® corrugated liner panels; DURACLAD® interlocking multiwall panels and new PALCLAD® PRO solid PVC wall and ceiling panels for use in interior agricultural, commercial, and residential applications.



TURN YOUR DREAMS INTO REALITY WITH THE NATURAL BEAUTY OF WOOD!



**PAVILIONS · ARCHES
 HEAVY TIMBER TRUSSES
 BRIDGES · POSTS · BEAMS**



717.866.6581
WWW.RIGIDPLY.COM
 701 E. Linden Street, Richland PA 17087



Pelican Bay Forest Products

Booth #321

18 NW Oregon Ave #100
Bend, OR 97703
541-312-9522
www.pelicanbayfp.com

Since 2000, Pelican Bay Forest Products has been a trusted wholesale supplier for the lumber community. We specialize in southern yellow pine but also have our hands in all softwoods, such as douglas-fir, hem-fir, SPF, OSB/Panels, and steel. We, at Pelican Bay, like to be a one-stop shop for all of our customers' needs. You can be assured we have the connections, experience and inventory to help your business grow. We rely heavily on our relationships with mills. What sets us apart at Pelican Bay is we stand behind what we say we will do until the task is completed.



Perma-Column, LLC

Booth #209

400 Carol Ann Ln.
Ossian, IN 46777
800-622-7190
sales@permacolumn.com
www.permacolumn.com

Perma-Column® is a patented line of precast concrete and steel products. Certified by ICC, the authority on building code compliance, enabling builders to more quickly attain approvals and permits. Perma-Column is designed to solve the industrywide problem of rotting wood in post-frame foundations. In addition, the Sturdi-Wall steel anchor bracket system, "The Best Post Frame Bracket in the Industry", allows for construction on traditional concrete foundations. Build Better, Build Stronger, Build to Last!



Plyco Corporation / East Coast Fasteners

Booth #607

500 Industrial Drive
Elkhart Lake, WI 53020
800-558-5895
marketing@plyco.com
www.plyco.com

For over 70 years, Plyco has been a leading supplier of products to the post-frame, metal clad building and commercial construction industries. Providing metal doors, windows, horse stall systems, ventilation products, reflective insulation, fasteners and closures and more.



Post-Frame Builder Show

PO Box 255
Iola, WI 54945
920-216-3007 - Missy Beyer
missy@shieldwallmedia.com
www.postframebuildershow.com

Post-Frame builders face the same business needs and challenges. Our First Annual Post-Frame Builder's show is all about resolving them. We're bringing together the suppliers, industry leaders, and technological solution providers in one space. Come mingle with the experts, shop for solutions, and make connections in Branson, Missouri, June 19-20.



Post Protector, Inc.

Booth #100

PO Box 187
Pottsville, PA 17901
570-624-7030
570-624-7031 (fax)
ken@postprotector.com
www.postprotector.com

Post Protector is a slide-on barrier system, delivering serious post-decay protection. Post Protector tackles post longevity concerns by eliminating both soil/concrete-to-post contact and chemical migration. Post Protector retains the simplicity, affordability, speed and strength of typical post-in-ground construction techniques. Horizontal perimeter ribs, in conjunction with provided hardware, yield substantial post uplift protection, and best of all, installation is a snap. It's simple: By keeping soil out and treatment in, Post Protector dramatically improves post-frame foundations.



Red Dot Products

Booth #617

465 N Reading Road
Ephrata, PA 17522
717-327-4089
717-740-6644 (fax)
www.rdproducts.net

Most rollformers, metal distributors, and building supply companies are limited by their inventory space and can't hold everything their customers ask for. We use our purchasing power and warehouse space to provide you with

competitive pricing and fast shipping for coils, fasteners, snow retention, color-matched accessories, and more. Let us be your warehouse and grow your business.

RICHLAND

LAMINATED COLUMNS LLC

Richland Laminated Columns LLC

Booth #320

8252 State Route 13
Greenwich, OH 44837
419-895-0036
419-895-0062 (fax)
twilson@richlandcolumns.com

We are your "One Stop Pole Shop" manufacturer/wholesale. We manufacture and distribute NEW Precast Concrete Skirt Board, Glulam Poles, Nail-Lam Poles, Perma-Columns, Sturdy-Wall Brackets, GreenPost (Polyethylene Plastic Wrap), Post Protector/Grade Guard Sleeves and The Footing Pad. With several different foundation options available for your post frame building, turn to Richland Laminated Columns for the most trusted and recognized products available. Please call for more information or to find a dealer near you.

RIGID BUILT

Laminated Columns LLC

Rigid Built Laminated Columns LLC

Booth #712

2446 Hwy S40
Allerton, IA 50008
641-203-3899
rigidbuiltlc@gmail.com

Rigid Built Laminated Columns manufacturers quality nail laminated columns. Engineered, structurally finger jointed, glued and nailed for straighter, stronger columns. Our standard columns are 6 foot minimum treated, treated with CCA .60 for superior rot resistance. We

can also do fully treated, untreated and center Knockout. We also sell Everlast Foundation Columns which is a 5-foot precast concrete column. These feature a built-in uplift restraint so you don't have to add these on the job site. We strive for great service and quality product.

SHIELD WALL MEDIA LLC

Shield Wall Media

PO Box 255
Iola, WI 54945
715-252-6360 (Publisher/CEO)
subs@shieldwallmedia.com
www.shieldwallmedia.com



Shield Wall Media owns Garage, Shed & Carport Builder Magazine and the Garage, Shed & Carport Builder Show. Visit the booth for free subscriptions to each of the company's expanding line of titles, including Rollforming Magazine, Frame Building News, Metal Roofing Magazine, Rural Builder, Roofing Elements, Metal Builder, and Garage, Shed & Carport Builder.



SAVE TIME, LABOR, AND HASSLE COMPARED TO CONCRETE

FootingPad® footings are engineered using a fiber-reinforced composite that is exceptionally strong, lightweight, and superior to concrete.

- Complete jobs faster, more easily, and generate more profit.
- Five sizes are available for use with most post types in below-grade applications.









Visit FootingPad.com or call **800-522-2426**

Perfect for decks, post frame buildings, and other post-supported structures.



Signature Steel

Booth # 110

4577 Hwy 412
Hindsville, AR 72738
479-325-3000

info@signaturesteelwa.com
www.signaturesteelwa.com

Signature Steel is a locally owned and operated small business in Northwest Arkansas that offers quality custom sheet metal fabrication for residential and commercial metal roofing panels as well as metal wall panels. We stand behind our work 100% and our customer service and timely production is our top priority.

We also offer custom trim, an assortment of matching screws, closures, insulation, doors and more for all your building needs.



Silvercraft, LLC

Booth # 517

11903 CR 30
Goshen, IN 46528
574-825-8757

lynn@silvercraftllc.com

Tired of assembling Dutch doors on the job site? Silvercraft is the home of pre-assembled aluminum Dutch and sliding doors. Just take it off the skid, and it's ready to install. Fasten the D-latch (pre-drilled) and safety hook. Done. These premium doors are available for any equine facility or hobby building. Fully-welded aluminum frames are powder coated for long life. Flat steel sheets are available to match most metal colors. Needing light in the barn? Consider doors with tempered glass tops to allow natural light into your barn.



SmartBuild Systems

Booth #413

PO Box 20627
Boulder, CO 80308
303-579-6277
303-443-8033 (fax)
sales@keymark.com
www.smartbuildsystems.com

Now supporting full barndominium design in under 30 minutes, Smart-Build is the construction industry's only complete design system for pole buildings, all metal buildings and roofing. This simple, web-based software quickly generates a 3D model, materials list, pricing, proposals, and construction documents for almost any building structure or roof. If you supply the post frame or metal building industry, let us show you why SmartBuild is the marketing tool for cementing your relationship with these customers.



Snap-Z

Booth #703

330 Swamp Road
Morgantown, PA 19543
717-572-0910
info@standingseamroofvent.com
https://snapzvent.com

Most standing seam ridge vents are too complicated to install. With SNAP-Z, installation is easy, and you can relax knowing that it won't fail over the lifetime of the roof and will vent adequately, in turn giving you satisfied customers and no call-backs. SNAP-Z has undergone rigorous testing by independent labs to ensure its standing seam ridge vent will withstand the worst elements and maintain the beautiful hidden fastener look that everyone wants. SNAP-Z currently supports 1", 1-1/2", 1-3/4",

and 2" profiles. Have a more complex ventilation situation? Get in touch with SNAP-Z to see what can be specifically designed for you. "Do It Right."



Speedlap LLC

Booth #711

21868 Driftwood Blvd
Bloomfield, IA 52537
888-752-7552
sales@speedlap.com
www.Speedlap.com

Speedlap sets the standard as the premier cut-to-order steel soffit manufacturer and wholesale supplier to the roll forming industry. Steel soffit panels are our only product, and we guarantee a quality product with a quick turnaround. Ensuring that in the end we help create Happy Jobsites!



ST Fastening Systems

Booth #611

6357 Reynolds Road
Tyler, TX 75708
800-352-4864
800-352-3940 (fax)
www.stfasteningsystems.com

ST Fastening Systems manufactures steel-frame and postframe fasteners for agricultural, industrial, commercial, and residential metal roof and sidewall applications. Product strengths are drill point quality and corrosion resistance, as shown by the WOODBINDER MB drill point and ZXL zinc aluminum alloy molded head. Both products are enhanced by a powder coating paint system. Solid and vented closure strip systems, pipe flashings, and other accessories round out the product line.



SWI Machinery

Booth # 101
 85 Howell Ave.
 Fairburn, GA 30213
 770-891-4388
 info@swimachinery.com
 www.swimachinery.com

SWI, an international leader in cut-to-length sheet metal machinery, utilizes state-of-the-art technology to drive our superior Simplex and Duplex Folders, Marxman Automatic Slitters, Un-coilers, and Recoilers. SWI is recognized as the go-to provider for reliable, efficient technology, as evidenced by countless

machines in operation today across the globe. Our machines are fast, flexible, and easy to operate, and with a host of advanced high-end features, you'll be amazed at what they can do to maximize your production time. Effective and reliable mechanical designs make SWI a number one choice for your most demanding sheet metal needs.



T&H Lemont, Inc.

Booth #817
 5118 Dansher Road
 Countryside, IL 60525
 708-482-1800
 sales@thlemont.com
 https://thlemont.com

The engineering staff at T&H Lemont, long known for its expertise in designing and building robust, innovative tube and pipe mills, likewise has a deep reservoir of roll forming knowledge. So if you need a machine for making roofing panels, ag panels, boards and battens, or items such as aprons, flashing, caps, drip edges or trim pieces, T&H Lemont delivers. Made in the USA.



**Download Your Copy Of
 The Shield Wall Media
 Business Directory
 2024 at**

www.shieldwallmedia.com/directory

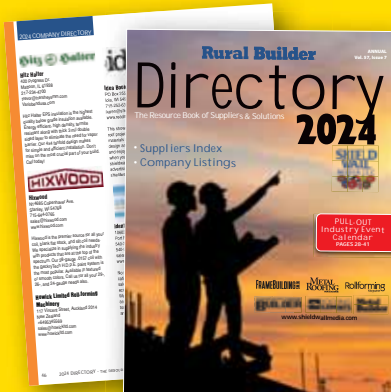

**To get your company into the
 2025 Directory, use our
 online form or contact:**

**Gary Reichert • 715-252-6360
 gary@shieldwallmedia.com**

DURABLE, HIGH-QUALITY ROOFING



At Hixwood, you'll find a huge inventory of heavy-gauge steel products for residential, ag or commercial roofing projects. Choose from Snap-Lock, Residential Rib 6", Super-Rib 9" and Commercial PBR 12" panels and a wide array of smooth and textured colors – plus 12 specialty finishes. Available in 24, 26, 28, and 29 ga.

Call today or visit us online for all your roofing needs.



715-644-0765 | HIXWOOD.COM



Trac-Rite Door

Booth #313

314 Wilburn Rd.
Sun Prairie, WI 53590
800-448-8979
608-824-6745 (fax)
tr@tracrite.com
www.tracrite.com

Trac-Rite Door manufactures quality steel roll-up doors for a multitude of uses including self storage, residential, agricultural, and commercial. Trac-Rite is dedicated to providing customized, worry-free, low maintenance products delivered with uncompromising service.



Tri-State Lumber Company

Booth #317

PO Box 39
Fulton, MS 38843
256-398-1993
tmcnutt@tristatelumber.net
www.tristatelumber.net

Located in Fulton, Mississippi, Tri-State Lumber Company specializes in manufacturing quality southern yellow pine timbers. We seek to manufacture and position our product as some of the highest quality lumber in the industry. We offer a wide range of products including 4x4 to 10x10 solid sawn timbers up to 32 feet in length. We take great pride in the quality of our products by always offering our customers a true #2 and better product. This same quality is continued in our treatment process by participating not only with in-plant testing but third-party inspection as well. The quality of all of our products is assured by Southern Pine Inspection Bureau and Timber Products Inspection. At Tri-State Lumber we are focused on quality and our products prove it!



Triangle Fastener Corporation

Booth #311

1925 Preble Ave.
Pittsburgh, PA 15233
800-486-1832
mgannon@trianglefastener.com
www.trianglefastener.com

TFC has been supplying the commercial construction industry with standard and specialty fasteners, tools, sealants, and accessories since 1977. From our 24 locations, we also specialize in providing hard-to-find items for critical applications. Ask about our inventory and delivery programs that reduce waste and shorten lead times.

We offer engineering services from our TFC TECH CENTER and can custom design fasteners for your specific application.



United Steel Supply

Booth #307

248 Addie Roy Road, Suite C200
Austin, TX 78746
512-263-0954
www.unitedsteelsupply.com

Welcome to United Steel Supply, your first choice for steel. United Steel Supply provides high quality flat rolled steel coils. We offer superior customer service, competitive pricing and just-in-time delivery, allowing us to achieve the highest level of customer satisfaction. United Steel Supply furnishes Galvalume®, galvanized and prepainted steel coils for metal roofing and siding applications to the agricultural, commercial, industrial and residential markets. Brands: 22, 24, 26 and 29ga flat rolled 40-year painted coil inventory. Acrylic coated in 22, 24, 26 and 29ga.



ViWinTech Windows & Doors

Booth #520

2400 Irvin Cobb Dr.
Paducah, KY 42003
800-788-1050
270-442-5610 (fax)
www.ViWintech.com

ViWinTech Windows & Doors is a family-owned company located in Paducah, KY. Since 1986, 100% of our focus has been on manufacturing high quality vinyl windows and doors that will meet your project requirements. Our 300+ employees strive every day to produce great products that will enhance the view and energy performance on all Post Frame structures.



Weaver Tool Gear

Booth #523

PO Box 68
7540 CR 201
Mt. Hope, OH 44660
800-932-8371
800-693-2837 (fax)
www.weavertoolgear.com

Every product from Weaver Tool Gear is built to last using the finest materials and skilled American workmanship. Our rugged line of construction gear is assembled in Mt. Hope, Ohio by craftspeople with an uncompromising attitude toward quality. Our belts are designed to be comfortable, long lasting and uniquely functional for framing, roofing, trimming and electrical. Our products are constructed with premium materials coveted for their su-

preme durability and weather resistance, from slash-resistant SuperFabric that lines every Super Tool pouch to heavy-gauge nylon thread that's stitched into each belt. We select the best materials that minimize wear and increase the longevity of your gear.

We understand the importance of all-day comfort. That's why we've incorporated features like AirFlex technology into our belts with specialized channels to maximize airflow and keep you cool and harness leather that conforms to your body over time for a custom fit. Our gear keeps you comfortable so that you can focus on the job at hand.



Wildcat

Booth #507

**21868 Driftwood Blvd.
Bloomfield, IA 52537
888-308-7858
sales@wildcatcompany.com
www.wildcatcompany.com**

Wildcat provides the best Metal Roofing Fasteners all across the United States. With Free Shipping and No Minimums on Fasteners, we can get product to your business with your needs being our number one priority. Based in the Midwest, we are able to provide our customers with great lead times on all products. Call Wildcat for Great Service and Fantastic Fasteners!



WINTech
An Employee Owned Company

Wintech Inc.

Booth #716

**201 Industrial Drive
Monett, MO 65708
417-235-7821
dcaraway@wintechinc.com
www.wintechinc.com**

As an employee-owned company, we take immense pride in delivering excellence. Our commitment extends to providing both standard and custom window products that perfectly cater to diverse needs across the construction market. Choose WinTech for quality, reliability, and a personalized touch that goes beyond the ordinary. Elevate your construction projects with our exceptional range of vinyl and aluminum window products.



Yoder Precast & Concrete LLC

Booth #712

**2870 210th Street
Seymour, IA 52590
641-203-7772**

Yoder Precast was founded in 2017 by Yoder Concrete, a family owned business since 1998. In early 2022 we were first introduced to the possibility of manufacturing engineered precast foundations for the frame building industry. After extensive testing and many discarded samples, we finally put our first foundations on the market in the fall of 2023. We look forward to serving the industry in the years to come.









GOTHIC ARCH



MONO



GAMBREL



TIMBER TRUSS

LAM-PLY-TRUSS

RIDING ARENAS • CATTLE ENCLOSURES • STORAGE • SHOPS

- Spans up to 72 ft.
- Bird nesting control
- Up to 12 ft. spacing depending on desired load
- No feed alley post obstruction
- Additional ceiling height for more usable space

starwoodrafters.com • 715-985-3117 • 888-525-5878



Culture is Everything

Amerilux Follows Their Playbook For The Win.

Sometimes you realize that if you want to make your dreams come true, it's now or never. In 2004, in collaboration with Jon Voss and Tami Churchill, Kurt Voss started on a new venture. Kurt had always dreamed of owning his own business, and he decided it was time.

The company began with three people, and a dearth of working capital for growth and navigating the challenges of adding people. Kurt said that really throughout the growth of the last 20 years, people have been the main challenge, and challenges are what business is all about. Yet, the company now has 230 employees, and Kurt (Jon and Tami have since retired) is proud of the team they have assembled.

SO IF PEOPLE ARE A CHALLENGE... HOW DID THEY GROW?

Amerilux believes it comes down to culture. They have a "How We Succeed Together" document that lays it all out. Their "mandates" include:

- **Make a Play!** The company culture says that team members

are predisposed to take reasonable action, knowing that they will make mistakes along the way, but preferring that to allowing outside influences to determine their path.

- **Don't Confuse Activity with Results.** Activity is judged based on the meaningful results it produces.
- **Conflict is a Good Thing!** Conflict is communication and often as team members discuss what the "right thing" is to do and the "right way" to do it, new ideas are born.
- **We Don't Drink Our Own Kool-Aid.** This means that



successes are handled with humility. False paradigms are avoided so that new ideas and information are not shut out.

• **Don't Judge People on Their Worst Moments!** "In the pursuit of excellence, we never lose our human compassion. We look for the overall pattern of good in people, and encourage people to succeed by playing to their natural strengths."

Other important concepts play their part in this intentional culture, but above all, the team is committed to a Win/Win framework, believing that "Every sustainable relationship, personal and professional, must be based on win-win for all parties. We invest in creating wins for all stakeholders in AmeriLux: employees, investors, customers, vendors, and the community." That seems like a pretty strong playbook.

Not only does such a positive culture create a better environment for everyone, it makes it easy for employees to know

what is expected of them in their actions and communications, allowing them to focus on other things. It also helps the company develop a reputation that is attractive to people looking for an opportunity.



AmeriLux International Warehouse

HOW DOES THIS WORK?

Naturally, it is easy to make up guidelines and hope it makes things better, but Voss says, it doesn't work that way. These statements are part of every interview with employees, whether it's a job interview or a performance review, and it is incorporated into meetings and used to ensure that the team remains true to their values.

The other piece of how this works is that the culture not only attracts people who want to work at winning, it nurtures that kind of drive. Voss said, "When you have a big team all chasing potential, you need to offer a bigger track for them to run on." Growth becomes an inherent part of work.

Polycarbonate Sheets & PVC Liner Panels

AMERILUX INTERNATIONAL
CELEBRATING 20 YEARS

Increase natural lighting with Polycarbonate Skylights, Sidelights, Eaveights & Ridgelights

Cost-effectively clad walls & ceilings with PVC Liner Panels

2024 POST-FRAME BUILDER SHOW
BOOTH # 510

www.AmeriLux.com

Manufacturer Of Metal Roll Forming Equipment

ABOUT US

Meet the growing customer demand for steel roof materials with an efficient, automated system that's ready to work when it hits the production floor.

OUR SERVICES

- » Versatile Growth Options
- » Shipping & Installation Available
- » Customer Support
- » Power Options
- » Pre-Tested Machines
- » Acu-Form Thru-Hardened D2 Steel

COME SEE US

June 19-20, 2024

2024 POST-FRAME BUILDER SHOW
BOOTH # 407

Contact For More Info ↓

10850 County Road 320 P: (330) 674-4403 wayne@acu-form.com
Millersburg, OH 44654 F: (330) 674-4035 acuformequipment.com

WHAT DOES AMERILUX DO?

With the kind of cultural commitment the company exhibits, it's almost unimportant what product or service they produce. Voss said that if they made potato chips, they would be successfully making some of the best potato chips out there.

However, Amerilux's customers are glad that they distribute plastic sheeting including polycarbonate and PVC in various profiles, plus acrylic, HDPE, and related accessories. They serve all markets in the construction industry as well as some manufacturers.

Amerilux is also a manufacturer of window wells and Shape Products, thermal forming and compression molding. The company is adding a new product to their lineup: DuxxBak, composite decking.



Kurt Voss, CEO

They consider themselves a value-added supplier; they talk to the customer to see what they need, doing some pieces of the prep work, fabrication, and assembly for customers where they can. As per their cultural directive, they are always striving for the win/win. From their headquarters in DePere, Wisconsin, the team ships supplies across America and Canada.

WHERE SHOULD A COMPANY START?

Voss's advice to people starting out in the industry, or any industry: "Find the value proposition that resonates in your market. Make sure you have working capital to fund your big ideas, to nurture them, and to get to the finish line. Finally, remember, you are in the people business... you're ALWAYS in the people business," he added. **RB**

LET US BE YOUR WAREHOUSE

2024 POST-FRAME BUILDER SHOW BOOTH # 617

Expand your inventory without maxing out your space.
Red Dot's warehouse brings you closer to a wider range of coils, metal panels, fasteners, and more, ensuring competitive pricing and quick delivery. Expand effortlessly, meet customer demands more efficiently.

CALL US TODAY!

833-473-3368
Fax: (717) 740-6644
465 N Reading Rd, Ephrata, PA 17522
RedDotProducts.com

HOURS:
Monday - Friday: 7 AM - 5 PM
Saturday: By Appointment
Sunday: Closed

RED DOT PRODUCTS

rFOIL®
Reflective Insulation

THE BEST WAY TO INSULATE

RIMA International Verified US-006-10
Reflective Insulation Manufacturers Association International

- Blocks 96% of radiant heat transfer
- Class 1/A Fire-Rated
- Prevents interior condensation
- Unaffected by humidity
- UV resistant

- Metal roofing
- Garages & carports
- Post frame buildings
- Pre-engineered steel buildings
- Pole barns & agricultural buildings

Contact us for more information
888-887-3645 www.rFOIL.com



Barn-Style Home

Gambrel Roof Post-Frame Residence Creates a Picturesque Scene

This gambrel roof home with dormers and self-supporting overhang is connected by a convenient breezeway to a garage with cupola. The buildings' design evokes a rustic farm setting. **RB**



THE DETAILS:

Building: Post-Frame Home

Building Size: 40'x50'x12'

Roof Pitch: Gambrel

Doors: Amarr

Fasteners: SPI

Insulation:

Bay insulation, fiberglass R-29

Posts: Worldwide Steel Buildings,
6"x6"x3/8" steel tubes

Roof Panels: Central States
Manufacturing, Panel loc Plus 29ga

Trusses: Worldwide Steel Buildings,
open web truss with straight steel
columns

Wall Panels: Central States
Manufacturing, Panel loc Plus 29ga

Additional Details: MWI, 36" 29ga

For more information:

www.worldwidesteelbuildings.com

Ready Column™ System

Simply cut & fit columns on site with our patented locking base system.

Patented Locking Base System

CODE COMPLIANT

Ready-to-install when you need them. Just cut to length, assemble and install.

readyheader.com | 631.587.8714

DMI = BUILDING INVESTMENT PROTECTION

Let DMI complete your building project with Code Approved & Warrantied:

HWB & PANGAKE FASTENERS • ANCHORS • PIPE FLASHINGS
REFLECTIVE INSULATION • POLYCARBONATE PANELS
SOLID & VENTED FOAM CLOSURES

www.directmetalsinc.com 855-800-8878

Green Post™
Planet Saver Industries

THE MOST AFFORDABLE, ALL-IN-ONE SOLUTION FOR IN-GROUND POST DECAY AND UPLIFT RESTRAINT

P (610) 377-3270
www.planetsaverind.com

Made in the USA

MASTER FLASH®

ROOFING • PLUMBING • ELECTRICAL • HVAC • SOLAR

From the smallest to the LARGEST, the most complete line available.

Pipe Range: Fits: 1/8" to 39-1/2" Pipes
Base Range: 2-1/4" to 44" (1 meter)

1-800-WASHER 5 (927-4375) • Ph: 858-513-4350 • info@aztecwasher.com • www.aztecwasher.com

PREMIUM QUALITY ROLLFORMING MACHINERY

ASC MACHINE TOOLS, INC.
MADE IN THE USA • EST. 1949

PANEL LINES	CZ PURLIN LINES
TRIM LINES	CHANNEL LINES
SLITTING LINES	ROLL UP DOOR LINES

WWW.ASCMT.COM TEL: (509) 534-6600

Everlast Roofing, Inc.

OUR NAME SAYS IT ALL

PROFILE OPTIONS

EVERLAST II™ EVERDRAIN™

WHY EVERLAST?
AZM™ with Activate Technology
Synergy® Paint System
Cut Edge Corrosion Inhibitor™ (CECI™)
Heat Forming
Most corrosion resistant panel in the industry

AZM ACTIVATE TECHNOLOGY

Lebanon, PA 10 Enterprise Court Lebanon, PA 17042	Howe, IN 7180 N 050 E Howe, IN 46746	Bridgton, ME 24 J.R. Harris Drive Bridgton, ME 04009	Orwell, OH 161 Grand Valley Ave Orwell, OH 44076
---	--	--	--

FOR MORE INFORMATION CALL: 888.339.0059 OR VISIT US AT WWW.EVERLASTROOFING.COM

WE ADD THE VALUE TO THE METAL

MARION MANUFACTURING

- Automation Systems
- Metal Construction Rollformers
- Coil Processing
- Forming & Fabrication
- Recondition Existing Machines

620-382-3751
www.marionmanufacturing.com

HEAVY-DUTY ANCHOR BRACKETS

Sturdi-Wall® drill set model
Sturdi-Wall® Plus wet set model
ICC-ES certified code compliance

permacolumn.com

PERMA COLUMN.

BUILD BETTER. BUILD STRONGER. BUILD TO LAST.

Golden Rule
FASTENERS
QUALITY PRODUCTS
COMPETITIVE PRICES
& MOST ORDERS SHIP THE SAME DAY

- Screws • Closures • Ridge Vent
- Pipe Flashings • Butyl Tape • And much more!

Ph: (334) 283-4030 - FAX (334) 283-4032
info@goldenrulefastenersinc.com - www.goldenrulefastenersinc.com

UNITED
STEEL SUPPLY

STEEL PRODUCTS FOR THE METAL ROOFING & METAL BUILDING INDUSTRY

Understanding Superior Service

512-263-0954 • unitedsteelsupply.com

rFOIL[®]
Reflective Insulation

THE BEST WAY TO INSULATE METAL ROOFING

CLASS 1/A Fire Rating

888-887-3645
www.rFOIL.com

Manufactured by: **COVERTECH**

RED DOT
PRODUCTS

COIL SALES

We source coils direct from the mill for **better quality and pricing.**

833-473-3368
Fax: (717) 740-6644
465 N Reading Rd, Ephrata, PA 17522
RedDotProducts.com

HOURS:
Monday - Friday: 7 AM - 5 PM
Saturday: By Appointment
Sunday: Closed

CUSTOM WIDTHS & LENGTHS

Manufacturers of Shed Type, Residential, and Medium Duty Commercial Garage Doors

KEYMAR^{MFG.}

Arthur, IL 61911
sales@keymar.net
217.543.2828

MANUFACTURER OF ROLL FORMING EQUIPMENT

Acu-Form
ROLL FORMING EQUIPMENT

- Coil Upenders • Shears • Slit Line • Uncoilers • Trim Roll Formers
- Wrappers • Panel Lines

Millersburg, Ohio
(330) 674-4003 - ACUFORMEQUIPMENT.COM

SteelGrip SAMM, Inc.
Preventing Injuries and Saving Lives[®]

SAMM MATS:
Easy to use magnetic grip provides safer footing when working on steel roofing. Get maintenance jobs done faster and easier.

SteelGrip SAMM
Safety Assist Magnetic Mat

231-944-0109
SteelGripSamm.com

WRAP THEIR BUILDING UP WITH WARMTH! **NEW!!!**

FAST • EASY • LOW COST

Retrofit Clip

www.retrofitclip.com • retrofitclip@hotmail.com
1-800-431-9661 • Manitoba, Canada



Ameripak
N C

- Simplify the process of safeguarding your load during transport by using one of our wrappers to secure your product!

502.222.8244
www.Ameripak.net
2009 Button Ln. LaGrange, KY 40031

Check Out Our Digital Magazine Websites

www.ruralbuildermagazine.com

www.framebuildingnews.com

www.readmetalroofing.com

www.rollformingmagazine.com

www.garageshedcarportbuilder.com

www.roofingelements.com

POST-FRAME BUILDER SHOW

June 19-20, 2024 • postframebuildershow.com

Construction Rollforming Show

September 18-19, 2024 • constructionrollformingshow.com

DID YOU KNOW?

It costs less to buy a Business Card ad than it does to have cards printed. We even give your "cards" to more than 40,000 potential customers.



**Actual Card Size
(3.5" x 2")**

FOR MORE INFO CONTACT GARY REICHERT:
gary@shieldwallmedia.com • 715-252-6360

METAL ROOFING
MAGAZINE

Rollforming
Magazine

Rural
Builder

GARAGE • SHED • CARPORT
BUILDER

FRAMEBUILDING
MAGAZINE

ROOFING
ELEMENTS
MAGAZINE

Metal
Builder

What's New in Post-Frame

Exhibitors, attendees enjoy annual Frame Building Expo in Des Moines

For the better part of a week, Iowa was the hub of the post-frame industry. Frame Building Expo (FBE), sponsored by the National Frame Building Association, was held March 6-8 in downtown Des Moines at the Iowa Events Center.

The event hosted more than 160 exhibitors on the Expo floor. Several attendees polled said their most important objective was to find new products. If you missed the event but would like to learn about some of the products debuted in Des Moines, read on.

NEW PRODUCTS

Component manufacturer Plyco debuted some new innovations, which included its Designer Series doors — Series 92 and 20 — that are now available in several new colors, with textured panels, and with several frame colors. Plyco reported: “Customers can now choose from the various panels and frames to customize their doors.” Also, the Klik-Fit Trim Kit is a new addition to Plyco doors to “help create a stylish, finished look after installation.”

About the show, they said, “Overall, it was a great show. We had wonderful attendance in the booth looking at the new innovations and were able to have great conversations with current and prospective customers.”

Keith Dietzen shared an exciting project that SmartBuild currently has in development. “SmartBuild’s big deal was to show off our software Release 1.90, which will be used to design two levels of interior living space in a barndominium.” It was very well received; people had a strong interest in it.

Coming in 2024, SmartBuild is developing a software version for building design people. “After we came out with



The Rapid Framing System once again drew the attention of attendees.



County Line Concepts introduced several new tools for post-frame builders and metal roofers. PHOTO COURTESY OF COUNTY LINE CONCEPTS.



Planet Saver's Barry Hoffman answers questions about post preservation.

the 1.90 barndominium-specific release that can lay out the bath, kitchen, and other details,” Dietzen said, “we found we started to get inundated with inquiries from building designers. (Before, it was for builders and contractors.)” During the inquiries, the building design people said the tools they were using weren’t efficient in designing post-frame structures. “We did a deep dive with these people,”

Dietzen continued. “The tools that they have to generate a full set of drawings for a barndominium customer takes 10 to 20 hours. When they use SmartBuild, it has all the details including structural details. Building designers are saying it’s valuable the way it is, but we will be doing more. ... Once it’s fully developed, SmartBuild for building designers will take a 10- to 20-hour task and boil it down to less than 2 hours.”

Ultimately, a project will be able to go from design to price within the same day, he explains. The company will have some initial releases within the next 60 days, and then will be rolling out regular updates. “We’re going to connect the whole post frame industry to the architectural design community.”

Post-frame building and metal roofing supplier True Metal Supply exhibited at FBE for the first time this year. The company’s booth featured its post-frame buildings with Buffalo River Truss’ Parallel Chord Steel Trusses, as well as its Board & Batten Steel Siding with various Wood Print Coatings. “The steel trusses drew a lot of attention, as a hybrid building style. Many show attendees were intrigued by the 100’ clear span capabilities and ease of installation.” The company also reports its new Wood Print Coatings on its Board & Batten Steel Siding attracted both influencers and builders in the industry. “We expect these building components to continue growing over the course of 2024.”

The company also reported that in 2024, Sweat Shield™ condensation control will be a new focus. It creates a lasting barrier between the building’s metal envelope and the harmful effects of condensation. “This material is pre-applied to True’s Through Fastened Tuff-Rib panels and is designed for buildings with interior, exposed metal roofing.”

They said they “had an excellent experience, as we received quality leads and reconnected with industry partners. We’re excited to have the show in our home town, Knoxville, in 2025!”

Hixwood’s Paul Zimmerman said, “I always enjoy the NFBA show, with Iowa being in our core area. It was a very productive exhibit for our team. The seminars were very informative, I wanted to give a shout out to the barndominium seminar. This has great growth potential for the post-frame industry.”

Regarding Hixwood’s sponsorship of the Family Lounge, Zimmerman said, “With God and family first in our lives at Hixwood, it is natural for the company to sponsor the family lounge. A mother with

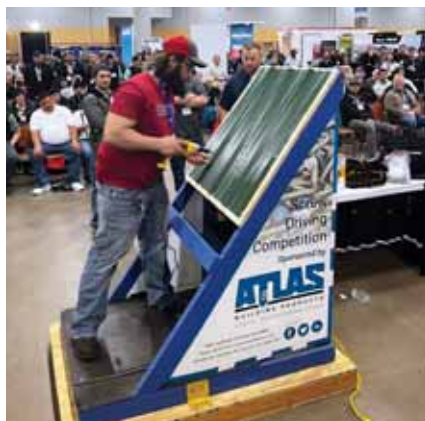

The popular Screw Driving Competition was once again sponsored by Atlas Building Products. PHOTO COURTESY OF ATLAS BUILDING PRODUCTS.

children that accompanied her husband to the show said, ‘I wonder if they realize how much this area is appreciated?’ It made it worthwhile, and I am hoping someday the children playing in the family lounge area will be leaders in the post-frame industry that we love so well.”

In addition to its standard line of tools, including the Ridge R-3:10 and the Ridge R-9, the County Line Concepts exhibit featured some new tools, including The Ceiling Panel Support for holding panels close to the ceiling for installation. Also shown were the Ridge R-Awl, used to give accurate marks on the panels, and the Mega Bracket, which sits over the rails on a mega deck and keeps materials and equipment off the floor. The Post Plummer, which allows for adjustment of the posts for a final, accurate alignment and the Pole Cat and Wall Lifter (used with your equipment to raise posts and walls into place) were also exhibited.

“The exciting part of our business is talking with contractors and getting ideas of what they are looking for and then bringing them to the table,” said County Line Concepts’ Gordon Moeggenborg. “We are always open for your input.”

Metal shear manufacturer Integrity Sales & Service, maker of the Dyna-Cut shared a bit of news. While the company didn’t debut any new products at the show, they do have some exciting tools in development. Keep watch for future announcements.



It was standing-room-only around the Maze Nails nail driving competition.

CROWD FAVORITES

A large crowd gathered around to watch the always-popular nail-driving competition, which was once again sponsored by Maze Nails of Peru, Illinois. A total of 47 contestants stepped up to compete. “We timed each contestant on how quickly they could drive three 40d (5-inch) Hardened Ring shank Pole Barn nails into a LVL Microlam Beam,” explained Len Kasperski of Maze Nails. “The nails were preset into the beam 1/2 inch for safety reasons. Each contestant raced against the clock to see who could drive all three flush to the surface the quickest. This was our 20th annual Nail Pounding Competition.” When the results were tallied, Joshua Gingrich came in with the fastest time of 8.75 seconds, earning him first place. The second and third place finishers, respectively, were Vernon Borntreger at 8.87 seconds and Eddie Conrad at 9.85 seconds.

Atlas Building Products once again sponsored the Screw Driving Competition. Three-man crews stepped up to drive 1” Woodtite fasteners into 29-ga. ag panels using a DeWalt 268 screw gun. “The winning team was Countryside Metals with a three-man team time of 43.7 seconds,” reported company spokesperson Amanda Edwards. “Coming in second was Timbercrest construction with a time of 47.52 seconds. The fastest individual was TJ Mast with a time of 13.2 seconds.”

Looking ahead, next year’s event takes place a little later in the year; the 57th Annual Frame Building Expo & Conference will be held April 2-4, 2025, in Knoxville, Tennessee. **RB**

1ST ANNUAL

POST-FRAME BUILDER SHOW

BRANSON CONVENTION CENTER • BRANSON, MO

JUNE 19-20, 2024



www.postframebuildersshow.com



**FOR MORE INFORMATION CONTACT MISSY BEYER:
missy@shieldwallmedia.com • 920-216-3007**

GET MORE INFORMATION ABOUT PRODUCTS & SERVICES SEEN IN THIS ISSUE. HERE'S HOW:



If you are looking for more information from companies featured in this issue, fill out this form.

Mail the completed form to us, and we will have those companies get in touch with you. There's no need to fill out multiple forms; we'll do the legwork for you.

Name (please print) _____

Signature (required) _____

Company _____

Address _____

City _____ State _____ Zip _____

Telephone (_____) _____

E-mail _____ Date _____

Please check one or more boxes to subscribe FREE/Renew for 3 years:

- Garage, Shed & Carport Builder Magazine*
 Frame Building News
 Metal Roofing Magazine
 Rural Builder
 Rollforming Magazine
 Roofing Elements Magazine
 Metal Builder

I would like to receive my subscription: By Mail Digitally

Check this box if you wish to receive our Construction Express newsletter and offers from our partners.

Email address is required to receive newsletter.

CONTACT NAME & EMAIL (OR) NAME & PHONE NUMBER ARE REQUIRED. WITHOUT THIS INFORMATION WE WILL NOT PROCESS THE REQUEST.

CHECK WHICH TITLE APPLIES TO YOU:

- President
 Owner
 Partner
 General Manager
 Sales Manager/Rep
 Engineer/Architect
 Vice President
 Foreman
 Installer
 Other _____

PLEASE CHECK THE PRIMARY CATEGORY THAT DESCRIBES YOUR BUSINESS:

- Builder, Dealer, Remodeler or Installer
 Roofing Contractor
 Metal Roofing Contractor
 Building Material Dealer/Distributor
 General Contractor/Remodeler
 Manufacturer/Rep of Manufacturer
 Architect/Specifier
 Construction Consultant/Engineer
 Building Owner/Developer
 Other (Please Specify) _____

ENGAGED IN THE FOLLOWING APPLICATIONS:

- Gutters/Accessories
 Institutional
 Residential
 Agricultural
 Commercial
 Industrial

SELECT A MAXIMUM OF 5 COMPANIES TO REQUEST INFORMATION FROM:

Company Name: _____ PAGE: _____

Company Name: _____ PAGE: _____

Company Name: _____ PAGE: _____

Company Name: _____ PAGE: _____

Company Name: _____ PAGE: _____

I understand that by providing the above information I hereby consent to receive communication regarding my subscription via US Mail, telephone, and e-mail sent by *Rural Builder*.

RB MAY 2024



Rural Builder Construction Diversity Provides Insight Across Markets

We are currently wrapping up the CSI — Annual & Market Report. We are running a little behind; new projects always do, but look for the report to land, free of charge, in your mailbox late May or early June.

Rural Builder is unique among our publications because it covers the widest range of construction styles and markets.

Virtually all the respondents involved in agricultural construction build for other market segments as well.

This provides an opportunity to compare across different segments, which highlights some similarities and emphasizes some differences.

Multifamily predicted the greatest increase in job size, with 58.1% looking at an increase. Agricultural had the smallest number predicting an increase in job size (42.7%) and the largest predicting smaller project size (15.9%).

Another area of contrast is how different segments view what new technology will impact the markets.

Technology and job size also correlate to other factors such as Gross Sales and New vs. Remodel. Larger project sizes would be more noticeable in companies building more and larger build-

Companies Who Build in Agricultural Market, Work in other Markets

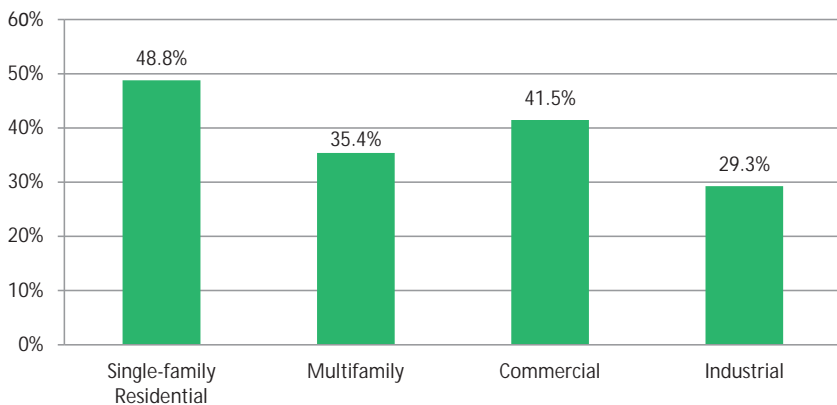

ings. And technology and increases in size would be more impactful in regard to new construction.

Look for a more detailed look in the CSI — Annual and Market Report mailing to you in Q2. **RB**

If you like the CSI columns or find the information useful, help us help you. Shield Wall media sends a State of the Industry Survey in fall and a mid-year State of the Industry Survey in Spring.

Projected Average Job Size

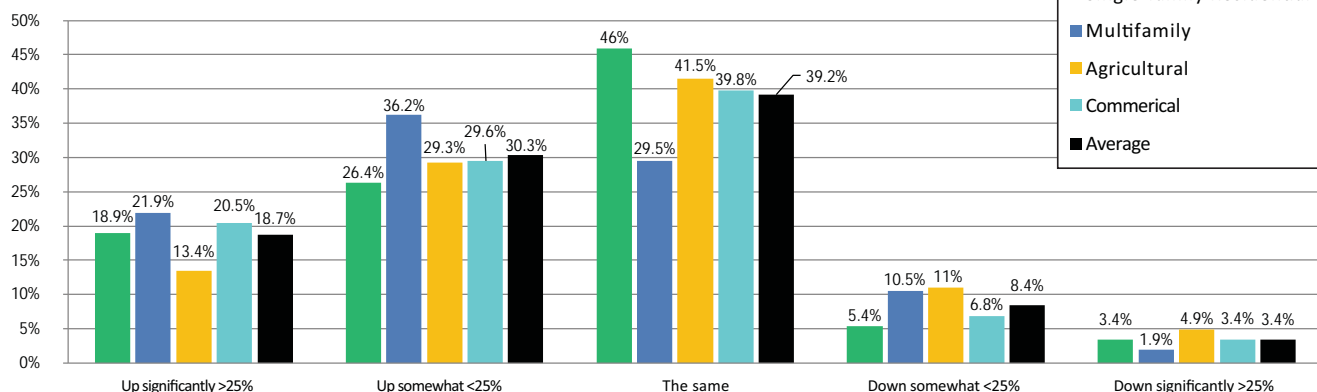



CONDENSATION CONTROL WHICH INCREASES PROFITS NOT LABOR COSTS

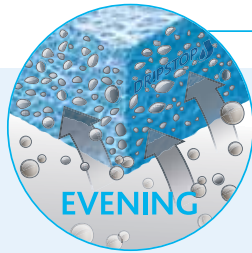

EVENING

Wet air rises up to the cold metal roof with Dripstop®



DRIPOSTOP®

Effective condensation control requires good building ventilation

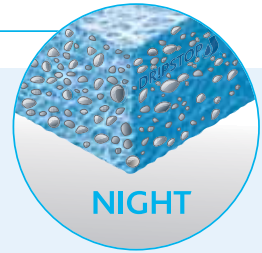
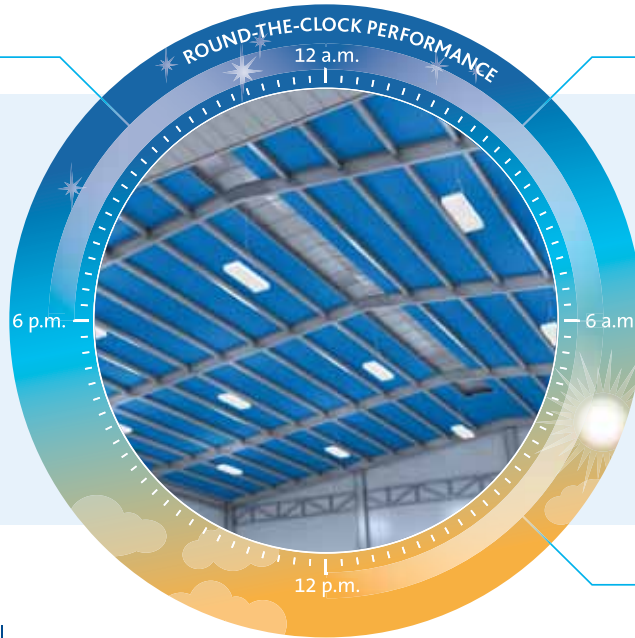

NIGHT

Moisture is trapped in the air pockets of the membrane

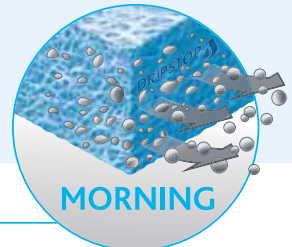

MORNING

Water evaporates and is vented out through the roof

A Necessity for Any Metal Roofed Building That is Not Climate Controlled.

- Post Frame/agricultural buildings
- Workshops/unattached garages
- Steel buildings
- Open-walled structures
- Self-storage
- Carports, truck ports & RV storage

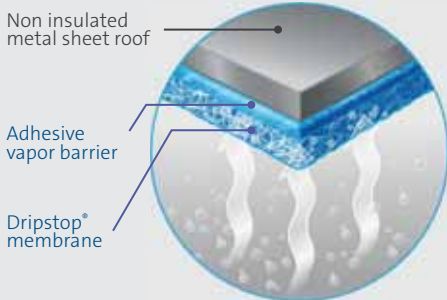

Better Science Equals Drier Buildings

When condensation occurs, moisture gets stored in the specially designed pockets of the Dripstop® membrane.

- Helps fight corrosion in livestock confinement
- Arrives on-site already on roof panels
- Cuts construction time in half
- Saves money



Get more information

Fight Condensation Without Insulation

Ask for it from your preferred steel panel supplier

Write to us info@dripstop.com or call us at: 1-(937) 660-6646