

INSIDE: STATE OF THE INDUSTRY REPORT

February 2017

Rural Builder[®]

The Business Management Magazine for Rural Contractors

www.ruralbuilder.com

NEW! AT THE EXPO
P.26



PLUS!

**HOW THINGS
ARE MADE**

AJ Manufacturing
Finds Its Niche

15

TOP PRODUCTS

YOU ASKED, THEY DELIVERED!

DOORS, WINDOWS, FASTENERS, PANEL

**Post-Frame
SOLUTIONS** p.26

Tips & Tricks

Removing moisture with ventilation



BUILT FOR POST FRAME

THE INDUSTRY'S LEADING MANUFACTURER AND SUPPLIER OF POST FRAME BUILDING ACCESSORIES

COME SEE US AT BOOTH #319 AT THE NATIONAL FRAME BUILDING EXPO

MARCH 8 - 10 IN NASHVILLE, TENNESSEE

• WE LOOK FORWARD TO VISITING WITH YOU •

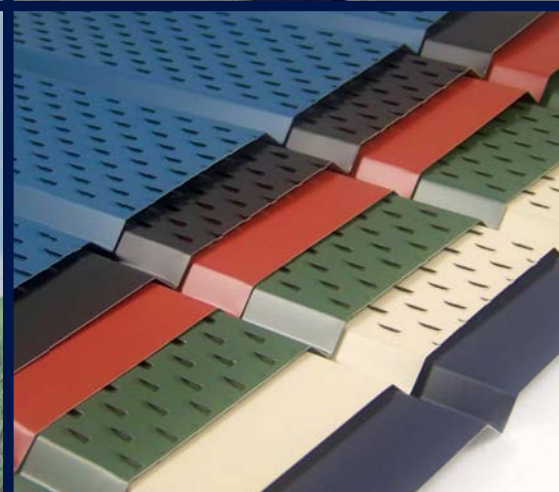
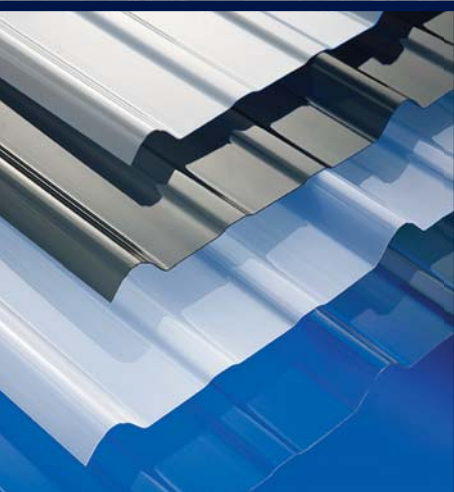

**MWI Components • www.mwicomponents.com
1015 32nd Ave West • Spencer, Iowa 51301
Ph: 800-360-6467 - Ext 5 • FAX: 800-361-3452**



Circle Reader Service #308



Rural Builder



Publisher/VP Advertising Sales
Dave Davel

Editor
Sharon Thatcher
sharon.thatcher@fwmedia.com
715-245-5767

Advertising Sales
Gary Reichert
gary.reichert@fwmedia.com
715-350-7080

Tyler Jensen
tyler.jensen@fwmedia.com
715-318-4505

Publication Design
Nicole MacMartin

Production Coordinators
Kathy Budsberg
kathy.budsberg@fwmedia.com
715-257-6020

Patti Kirchner
patti.kirchner@fwmedia.com
715-318-0839

Subscription Services
386-246-3452

Office Phone
715-445-2214

Office Fax
715-445-4087

F+W, A CONTENT + ECOMMERCE COMPANY

Chief Executive Officer Thomas F.X. Beusse
Chief Financial Officer Debra Delman
Chief Operating Officer Joe Seibert
Chief Content Strategist Steve Madden
Chief Technology Officer Joe Romello
SVP, General Manager- F+W Crafts Group John Bolton
SVP, General Manager- Small Business Group Ray Chelstowski
VP, Manufacturing & Logistics Phil Graham
Newsstand Sales Scott T. Hill
scott.hill@procirc.com

SUBSCRIPTION SERVICE

Subscription inquiries, orders and address changes can be made at constructionmagnet.com (click on "Subscribe"). Or by mail: Rural Builder, P.O.Box 421751, Palm Coast, FL 32142-1751. Or call (866)805-1574, International (386)246-3452

Rural Builder (ISSN: 0888-3025) Volume 51 Number 1 is published monthly, except January, April, June and November, by Krause Publications, a division of F+W Media, Inc., 700 E. State Street, Iola, WI 54990-0001. Periodical postage paid at Iola, Wis., and at additional mailing offices. Canadian Agreement Number: 40665675. POSTMASTER: send address changes to Rural Builder, Circulation Department, PO Box 420235, Palm Coast, FL 32142. Copyright 2017 by F+W. Rural Builder and its logo are registered trademarks. Other names and logos referred to or displayed in editorial or advertising content may be trademarked or copyright. Rural Builder assumes no responsibility for unsolicited materials sent to it. Publisher and advertisers are not liable for typographical errors that may appear in prices or descriptions in advertisements. Mailed free to rural contractors and their suppliers throughout North America. Others may subscribe: \$29.98 for 1 year, \$55.98 for 2 years, and \$79.98 for 3 years in the U.S.; \$39.98 for 1 year, \$74.98 for 2 years in Canada.



10

FEATURES [FEBRUARY 2017]

TOP PRODUCTS OF 2016 / 10

The products you asked for most

IN FOCUS / 20

State of the Industry Report 2017

NEW PRODUCTS AT THE EXPO / 26

Gotta'-Have-It Solutions for Rural Builders

EXPO EXHIBITOR PROFILES / 32

Learn More About the Companies Going to Nashville

MOISTURE PROBLEMS AND SOLUTIONS / 72

Part 5 : Protecting the Exterior Building Envelope with Proper Ventilation

DEPARTMENTS

Editor's Note..... 4
News 6
Calendar 8
Index 58
Project Feature 67
How Things Are Made 68
Classifieds 73

MARCH PREVIEW

- Co-Op Dollar Advertising
- Rural Builder Hall of Fame Inductees
- Product Feature: Windows, Skylights and Daylighting



32



68



E-MAIL THE EDITOR AT
sharon.thatcher@fwmedia.com

Check our website at
www.ruralbuilder.com

BY SHARON THATCHER

Let the Games Begin

AS I WRITE THIS, Donald Trump is a day away from taking office and most of Capitol Hill is still trying to figure him out and what his presidency will mean for the nation. I certainly have no answers, but I found that a lot of people in the construction industry are hopeful, while maybe a bit concerned, over a Trump presidency. There is hope that his business acumen will bring some stability to a nation that, by most measurements, has gone financially astray.

There is also concern that maybe government has become too much of a juggernaut for anyone to control.

During my time reviewing the results of our annual State of the Industry survey and reading through the sage observation of economic experts, time and time again Trump is mentioned. It's not really out of the ordinary. Every new president brings new hope, new promise, new worries. We'll see what the year brings and see what the next survey reveals.

In the meantime, take a look at the results of the current *Rural Builder* State of the Industry Survey starting on page 20. The report starts with a review of the results. Then comes some of the fun stuff: interviewing guys in the industry to get some "boots on the ground" feedback. The feedback this year comes from a very interesting mix. There is the retired sawmill owner on Kodiak Island, Alaska, Reed Oswald; Wisconsin builder Leo Souder, who has a long history in the industry and a good idea of what's going to be hot in his midwest market; and Mike Momb, our "Behind the Hammer" columnist who has his pulse on the national post-frame business.

On the lighter side, this issue offers a look at a lot of great products. It starts with a reveal of the Top Products of 2016, followed by a showcase of new products that will be attracting attention at this year's Frame Building Expo in Nashville.

Oh, so you don't know about the Expo? Well, we have profiles of the bumper-crop of exhibitors planning to be there.

A couple of new things are featured this issue as well. We have a feature project in every issue of *Rural Builder* this year. Our first was provided to us by Levi's Building Components.

The second is a new occasional series of articles called "How Things Are Made," featuring some of the manufacturers who have been mainstays in the rural builder market. First up: a visit to A.J. Manufacturing in Bloomer, Wisconsin. Enjoy! **RB**



Sharon Thatcher,
editor
sharon.thatcher@fwmedia.com
800-726-9966, ext. 13644

Build with Confidence Build with Wick Buildings

Wick Buildings has been helping farmers, families and businesses by providing long-lasting, low-maintenance buildings since 1954.

Buildings with quality and value...and no compromises. Join our team!

800-356-9682
WickBuildings.com



Agriculture ■ Suburban ■ Equine ■ Commercial

Stop by our booth #518 during the 2017 NFBA Frame Building Expo and enter to win a \$400 Lowe's gift card!



Circle Reader Service #511



AkzoNobel

**Consistent
and reliable
performance you
can count on.**

**CERAM-A-STAR®
1050 gives you
superior color,
quality, and
durability, time
and time again.**

Building a reputation of consistency and reliability takes time. For over ten years, CERAM-A-STAR 1050 has repeatedly proven itself as the finest silicone-modified polyester (SMP) coating for pre-painted metal. This history of consistent performance allows building owners to experience years of worry-free ownership, with superior chalk and fade resistance and exceptional gloss retention.



Booth #503

**Learn about the performance of
CERAM-A-STAR 1050 at:
www.akzonobel.com/ccna**

industry news

BY RURAL BUILDER STAFF

LELAND INDUSTRIES EXPANDS INTO NEW ADDITION

Leland Industries Inc., has added 50,000 square feet to its manufacturing plant and warehouse to meet growing demands for quality metal and post-frame building fasteners.

The addition was completed earlier in 2016, but work continued with equipment upgrades. New machines were installed and existing machines re-located, all the while maintaining production levels dictated by a demanding summer building season.

Leland, the first fastener manufacturer to introduce “powder coating” to match panel colors, increased capacity in this area by more than 60 percent to meet the demands of the industry.

Leland produces self-drilling and self-tapping screws in addition to bolts and nuts for agricultural storage and industrial building construction.

CENTRAL STATES MANUFACTURING OPENS FACILITY IN SEGUIN, TEXAS

Central States Manufacturing has opened a 44,000-square-foot manufacturing and warehouse facility in Seguin, Texas. The company says it is committed to creating 50 new, full-time jobs over the next three years. This project represents Central States Manufacturing’s 8th manufacturing facility.

“We are excited to begin operations in our new facility,” said Stan Pissarski, general manager of operations for Central States Manufacturing. “Seguin is the perfect place for a manufacturing facility for many reasons. From a transportation and logistics standpoint, our Seguin facility provides easy, direct access to Interstate 10, State Highway 123 and the State Highway 130 toll.”

Pissarski also mentioned the proximity of many of Central States’ business partners, such as Fastenal, Love’s, Home Depot, Office Depot and CMC Recycling Seguin, as a contributing factor to the company’s decision. The company has the added capability to load route trucks and support daily service to and from the southern point of Austin, south to Brownsville and west along the Interstate 10 corridor to Louisiana.

SEALTITE BUILDING FASTENERS MAKING A CHANGE

Sealtite Building Fasteners has changed its name to ST Fastening Systems, effective Jan. 1. The company will continue to use its iconic “flying” ST as part of its logo.

Joe Hargis, CEO and founder said the change reflects how the company has evolved. “In 25 years, we have become much more than a distributor of self-drilling screws,” he said. “The ST product line has grown to include a comprehensive array of construction products. Our proprietary fasteners cover all application requirements for metal and post-frame buildings, whether it be speed, strength or durability. In addition, our expansive line of components now includes the very highest quality venting, sealing, flashing and closure products.”

people in the news

BY RURAL BUILDER STAFF



BILLSTROM



HELMINK



LOGGER



RAUFEISEN

LESTER BUILDING SYSTEMS LLC has announced a series of organizational changes and promotions. Mark Billstrom has been promoted to the newly-created position of Vice President of Operations. His scope of responsibility includes the planning and execution of company-wide engineering, manufacturing, transportation and construction activities in an effort to improve operational performance.

Tyler Bennett has been promoted to the newly-created position of Planning, Procurement & Logistics Manager, and reports to Mark Billstrom. Bennett will lead Lester Buildings’ efforts to plan and schedule operational activities key to meeting promised ship dates.

Ted Helmink has been promoted to the new role of Engineering Services Manager. Also reporting to Mark Billstrom Helmink’s group is responsible for designing, detailing and defining production requirements for every Lester building.

Craig Loger has been promoted to Vice President of Sales. In his expanded role, Loger will assume sales management responsibilities for both the direct and dealer sides of Lester’s business.

Jeannette Raufeisen has been promoted to the newly-created role of Marketing and Customer Experience Manager.

• • •



HOGAN

S-5! has brought back Frank Hogan to fill the newly created position of Business Development Director, focusing on deepening relationships with the company’s OEM market to maintain market share and capture additional sales opportunities.

Hogan, who served as a national sales representative and field support manager for S-5! in the United States and Canada from 2007-2012, has held a variety of sales and management positions with several metal roofing manufacturers.

NOW AVAILABLE FROM **CANNONBALL**

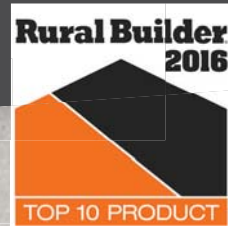

PELLA®

A white-framed window showing a view of a large tree with green leaves.

**IMPERVIA®
WINDOWS**

A white-framed window showing a view of a green lawn and trees.

- Duracast® fiberglass composite construction
- Powder-coat finish frames in multiple colors
- ENERGY STAR® and foam-insulation options
- The industry standard quality, durability & warranty

Recommended Project Use

	Agriculture	<input checked="" type="checkbox"/>
	Commercial	<input checked="" type="checkbox"/>
	Metal	<input checked="" type="checkbox"/>

Come see for yourself!
MARCH 8-10



Nashville, TN



800-766-2825 • Beloit, WI
www.cnbhnp.com

Circle Reader Service #386

BY RURAL BUILDER STAFF

■ APA UPDATE ON MOISTURE RESISTANT WALL CONSTRUCTION

APA—The Engineered Wood Association has updated its *Build a Better Home: Moisture Resistant Wall Construction* guide.

The publication outlines the primary sources of moisture in wood wall construction, leaks and condensation and recommends methods to prevent its accumulation.

Concerns about moisture damage and a shortage of well-trained construction trade professionals inspired the APA to provide an educational outreach program on the topic. It includes technical publications, videos and CAD details outlining proper moisture control techniques in construction applications, including cover groundwork, foundations, floors, walls and roofs.

APA's *Build a Better Home: Moisture-Resistant Wall Construction* publication is available for free download from the APA website [www.apawood.org/buildabetterhome]. Printed copies can be ordered through the website for a nominal fee.

02/

FEBRUARY

20-21, Iowa Lumber Convention, Prairie Meadows, Altoona, IA; Northwestern Lumber Association; nlassn.org

03/

MARCH

1-3, International Roofing Expo, Las Vegas, theroofigexpo.com

7-8, Nebraska Lumber Dealers Convention, Kearney, NE; nlassn.org

8-10, Frame Building Expo, Nashville, TN; nfba.org

15-16, North/East Roofing Contractors Association (NERCA), Atlantic City, New Jersey, www.nerca.org

28-30, Mass Timber Conference, Portland, Oregon. masstimberconference.com

04/

APRIL

27-29 American Institute of Architects (AIA) Convention, Orlando, Florida, www.aia.org

05/

MAY

18-20, 48th Annual MBCEA Conference, New Orleans, www.mbcea.org

06/

JUNE

11-13, Western States Roofing Contractors Association (WSRCA) Expo, Las Vegas, www.wsrca.com

22-24, Florida Roofing and Sheet Metal Association Convention and Expo (FRSA), Orlando, www.floridarroof.com

URESTONE

ACE

Electrical

- Fast and economical installation
- Interlocking 4x8' panels largest in the market
- Outstanding color and realistic deep textures
- Completely customizable colors, textures, sizes.
- Extremely Durable and light-weight
- High R-Value

MOST ECONOMICAL WAY TO REMODEL

BEST BUILDING E-PRODUCT 2016 Rural Builder

URESTONEPANELS.COM
ST. LOUIS, MO
P: 314-524-2040

GET A QUOTE FOR YOUR PROJECT TODAY



Protecting the protectors

APPLIED SCIENCE

Dura Coat's team of resin experts made sure that that Station 37's roof is as durable as it is attractive. Ceranamel will help it withstand Colorado High Plains weather extremes.

DURA COAT PRODUCTS, INC.

RIVERSIDE, CALIFORNIA
(951) 341-6500

HUNTSVILLE, ALABAMA
(256) 350-4300

www.duracoatproducts.com

WHEN THE NEW PLATTE VALLEY FIRE STATION WAS DESIGNED, it had to accommodate a range of professional emergency services such as fire, EMS, rescue and assists, as well as crew housing, community events, training and more. Quality was essential, but so was value.

For the metal roof, Dura Coat Products Ceranamel™ XT40S was specified, the finest coil coating available from resin specialists who are never sidetracked by making house paint or craft paint in spray cans. Ceranamel is tough enough to withstand Colorado winters and High-Plains heat. It applies fast and produces a ceramic/porcelain-type finish that is harder and more resistant to abrasions and stains than conventional coatings. And with an excellent hardness/flex ratio and internal lubricants, the coating handles the toughest roll-forming applications.

Ceranamel applies easily to primed hot-dipped galvanized, zinc-aluminum alloy steel, and aluminum substrates. Ceranamel is also Cool. Complying with Cool Roof Rating Council, Energy Star and LEED 29 standards, it helps the environment by reducing the carbon footprint. Protect your buildings 24/7 too.

Call 951-341-6500 for more information.



Circle Reader Service #581



The Top Products You Asked For in 2016

THE READER SERVICE CARD we offer in each issue of *Rural Builder* has multiple purposes. The primary purpose is to allow readers to request more information on products or companies that are featured in the magazine. At the end of the year, we go into our RSC system and pull the numbers to see what products and companies received the most requests for more information. That's how our Top 10 Products are determined.

We typically announce the Top 10. Sometimes, however the list grows due to a tie. That's the case this time. Our Top 10 is really our top 11.



Graber Post Buildings

1. GRABER POST BUILDINGS



Graber Post Buildings continues to be a phone call away from acquiring all post-frame building materials and do-it-yourself packages. GPB manufactures metal panels for any residential, commercial, industrial, agricultural or roofing application. It also produces custom trusses, metal trims, laminated poles and now features a steel coil division. **Circle: 240**

2. EAGLE METAL PRODUCTS



Eagle has been serving component manufacturers for more than 30 years with truss connector plates, TrueBuild structural design software, engineering services and manufacturing equipment, and is committed to providing exceptional products and customer service. Manufacturers across the country are discovering the advantages. **Circle: 241**



A.J. MANUFACTURING

3. A.J. MANUFACTURING



A.J. Manufacturing offers a complete line of durable high quality aluminum and vinyl windows. Options include horizontal sliding, fixed lite, casement, single hung, double hung, thermal, non-thermal, grids and Low-E glass. Transom windows and mullion kits to combine multiple windows create attractive architectural features. White, brown, bronze, clay or custom-colored windows and trim will enhance the appearance of your next building. **Circle: 242**

4. METAL SALES MANUFACTURING



Metal Sales Manufacturing offers a complete line of metal roof, wall and fascia panel systems for the agricultural, suburban, residential and commercial markets. Having celebrated 53 years of service in

DYNA-GUARD®



IT IS TIME FOR A **CHANGING OF THE GUARD**

DYNA-GUARD® snow retention system is designed to be installed on metal roofs. We are discontinuing the line of S-5!®/COLORGARD® and related products. Please call for our close-out prices on S-5!®

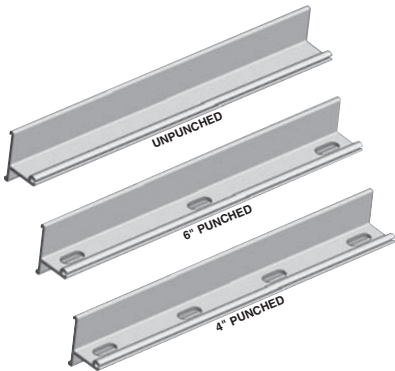

DYNA-GUARD is an 8' long extruded aluminum stick with a T-shaped profile stocked in: unpunched, 4" and 6" center punched. . . **AN EXCLUSIVE DYNA-GUARD ADVANTAGE!**



SNO-DAMS® inhibit the ability of snow and ice to slide under the installed DYNA-GUARD.



DYNA-GUARD® Snow Retention System installed on a metal roof.



DYNA-CLAMPS® are non-ferrous non-piercing clamps for various attachments to standing seam metal roofs.

- 1) DYNA-CLAMPS have undergone extensive testing by the esteemed Encon Technology, Tulsa, OK.
- 2) All DYNA-GUARD, DYNA-CLAMP and SNO-DAM items are extruded from aircraft quality, high tensile aluminum "6005A T61 Aluminum".
- 3) All of these components are proudly manufactured in the U.S.A.
- 4) Over the last 15 years, our factory has produced over *5 million pounds* of aluminum snow retention components for metal roofs.

Therefore, when you buy from us, you know that you are purchasing the highest quality parts manufactured by a proven veteran at supplying high quality snow retention components to our metal roof industry. Since we have a mutually exclusive relationship with our factory, you must purchase DYNA-GUARD and DYNA-CLAMPS to know that you're receiving the *true* time-tested results/benefits of dealing with our high quality factory.

We are factory-direct on all of these components. Therefore, our valuable contractor customers benefit by paying substantially lower prices. Our valuable O.E.M. customers benefit by eliminating minimum order quantities and by eliminating any lead-time – which can stretch out to unacceptable lengths of 4 or even up to 6 weeks with some of our competitors. O.E.M.'s; our huge inventory levels will translate into less of your cash tied up in your inventory and typically completely eliminate the frustration of dealing with needed items that are on backorder.

DYNAMIC FASTENER • 800-821-5448

S-5! and ColorGard are registered trademarks of Metal Roof Innovations Ltd. DYNA-GUARD, DYNA-CLAMP and SNO-DAM are registered trademarks of Dynamic Fastener Service Inc.

top products of 2016

BY RURAL BUILDER STAFF

2016, Metal Sales has the expertise to service post-frame builders and their customers' needs in new construction, expansion and retrofit. **Circle: 243**



5. SNO GEM INC.



The Sno Barricade MEC Deck Mount snow retention bar system features a mechanically-fastened flat-base bracket, which maximizes the contact surface with the roof and ensures an extremely strong attachment. The MEC deck mount system comes in mill finish or powder/Kynar coated to match the color of the metal roof or building. Options include a 1-, 2- or 3-bar system and either 1-inch or 2-inch size bars. Additionally, Sno Gem offers both square and round bars for all its Sno Barricade systems to best match your building's profile. **Circle: 244**



6. MWI COMPONENTS



MWI Components is now offering a simple and strategic line of vinyl windows for the post-frame industry. Offered are single hung and horizontal sliders with ½-inch insulated glass, removable insect screens, durable completely-welded construction, UW stable white vinyl, cast/zinc-painted window locks, continuous spacer primary seal, interior weeping system and deluxe wool pile seals. The single-hung option offers choice of with or without grids. The horizontal slider offers the option of with or without a built-in J-channel. Sizes and prices are available upon request. **Circle: 245**

SHEAR-XTM

Bracket

**INTRODUCING: THE
SHEAR-XTM STRENGTH &
VENTILATION SYSTEM**



For use on all types of buildings.

**SUPERIOR BUILDING STRENGTH
AGAINST SEISMIC AND
LATERAL WIND LOADS**

Continuous Ventilation and Stabilization for ANY Roof!

- Designed to transfer in-plane shear forces
- In-plane shear resistance capacities of 1750-2475 lbs.
- Allows for the use of continuous ridge venting
- Blocked & unblocked diaphragms
- Tested & ANSI certified
- RoHS compliant
- Makes your building stronger
- Use SHEAR-X Brackets and RidgeVent System with any type of roof

Garwood[®]
MANUFACTURING CO., INC.

115 Lismore Avenue • Glenside, PA 19038
800.300.9515 • shear-x.com



Circle Reader Service #464



DrJ Technical Evaluation Report #1509-03
Patents Pending

top products of 2016

BY RURAL BUILDER STAFF

7. TIE: APPLICAD-USA INC.



APPLICAD is celebrating more than 25 years helping roofing contractors around the world. During those 25 years, AppliCad has developed and refined its CAD software to deliver the most comprehensive and professional takeoff software worldwide. Developed in close cooperation with the industry, AppliCad software benefits roofing and cladding installers, contractors and distributors. It provides repeatable accuracy and quality of output and therefore ensures increased profitability for any roofing or cladding project on commercial, industrial or residential scale. **Circle: 246**

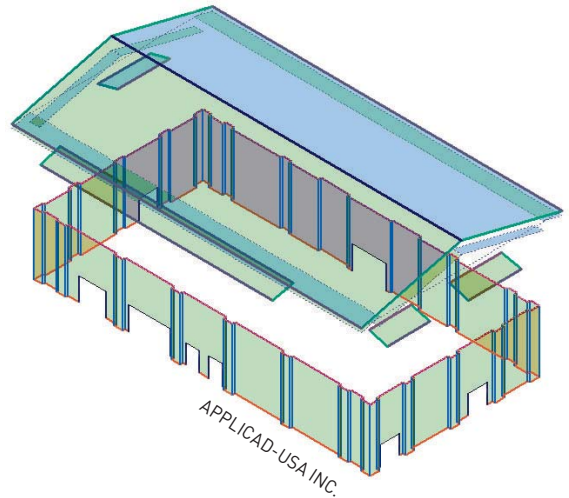

7. TIE: SFS INTEC



SFS intec is a premier manufacturer of metal panel attachment fasteners for the metal building and post-frame markets. Fasteners include the #9 woodGrip, #10 HiLo woodGrip with mill point and the #12 woodGrip XG with a large aggressive thread design for superior performance in OSB and plywood. Long-life fasteners include the everGrip bi-metal, woodZAC alloy cap and woodMAC SS capped fasteners. SFS intec is also a distributor for S-5! clamps, brackets and snow retention products. Other accessories include panel clips, ProfileVent ridge ventilation, pipe flashing and WG-7 foam closure. **Circle: 247**



8. PLYCO CORPORATION



Curved roof, straight roof, window kit options, premium base and more, Plyco has the cupola to add that finishing touch to your building projects. Available in 24-, 36- and 48-inch sizes, they assemble on the job site in minutes with slide-on metal connectors. Plyco cupolas can be color matched to most roll-formed steel colors. Top it off with one of several available weather vane options. **Circle: 248**



Fight Condensation Without Insulation

A Necessity for Any Steel Roofed Building That is Not Climate Controlled.

- Post Frame/agricultural buildings
- Steel buildings
- Self-storage
- Workshops/unattached garages
- Open-walled structures
- Carports, truck ports & RV storage



DripStop Stops the Dripping from Condensation.

When condensation occurs, moisture gets stored in the specially designed pockets of the DripStop membrane.

DripStop is applied at the time of roll forming

- Arrives on-site already on roof panels
- Helps fight corrosion in livestock confinement
- Significantly reduces construction time
- Saves money



When metal roofs are applied directly over shingles,



Protects the Metal and Your Investment.

Ask for it from your preferred steel panel supplier

Visit our website at www.dripstop.com

or call us at: 1-(937) 660-6646

Circle Reader Service #384



4 SIMPLE TIPS FOR WORKING WITH COPPER

COPPER ACCENTS offer a great opportunity to grow your business. Eye-catching dormers, gutters, louvers, spires, finials, chimney pots and cupolas add look and functionality so that even the simplest barn, home, church or office building can stand out from the crowd.

While installing fabricated copper products may appear complex, the reality is that copper accents can create an amazing, knockout look—while also being easy to install. Use these four tips to wow your customers.

Let Your Manufacturer do the Work: Most copper accents can be customized specifically for your project. With customization, the manufacturer does the heavy lifting, leaving you to perform a quick installation. When built to your project's roof pitch and material, copper dormers and accessories can be fitted directly over the existing roof material or attached to the roof deck before the roofing is installed. Be sure to select an experienced manufacturer who knows how to work with your structure and materials.

Copper Soldering: Field soldering specialized accents has become extremely rare. Many consumers, however, expect to see their copper gutters soldered. Together, copper and solder create an old world, hand-crafted look. Soldering also minimizes the number of fittings in a copper gutter run. Fortunately, copper gutter is very easy to solder, and most people begin to get a feel for it after soldering just a few joints. With just a little practice, you can become a fluent installer of copper-soldered gutter.

Keep it Clean: When installing copper, limit fingerprints and staining by wearing gloves and the proper protective gear. Keep a rag handy. When drops of perspiration hit the copper on hot days, wipe them off quickly to keep the surface clean. This easy, simple process helps ensure the copper looks great when you leave the job.

Don't Mix Your Metals: Always use copper, brass or stainless fasteners and accessories when working with copper. Steel and aluminum components will react with copper and cause premature corrosion.

Partnering with a manufacturer who stocks the right accessories, customizes products for easy installation and offers training and installation help makes working with copper satisfying and easy. With a little effort and the right partner, your buildings can collect serious ooh's and ahh's that help grow your business.



BY MARK MULLINS, FABRAL
Applications Engineer
Product Training Manager

Contributed by Fabral

top products of 2016

BY RURAL BUILDER STAFF

9. CANNONBALL:HNP



CannonBall:HNP marks its 100 year anniversary in 2016 with new product offerings in its

most popular product categories.

Red Roller Trolleys: With high quality Delrin wheel components, steel construction and a dash of CannonBall Red, this updated

trolley is the right eye-catcher to help lock down hardware sales on customers' round track orders. Available in CannonBall's most popular model this new hue, launched in January, was expanded to other round trolley models throughout 2016. *Interior Track Products:* CannonBall offers its first cohesive professional-grade interior track product line. Product models include an aesthetic Urban Flat Track design for home and commercial use and a Classic Round Track variety that provides added strength and functionality into the mix. Both lines feature beefy steel designs, black matte/powder coat finishes and a variety of sizes to handle door sizes up to 8 feet wide. **Circle: 249**



NATIONAL HARDWARE

10. NATIONAL HARDWARE



National Hardware's interior sliding door hardware can transform any opening or doorway. This unique, innovative design saves space and creates a decorative enclosure for any room. This diverse interior sliding door line now includes the most popular finish among consumers, Satin Nickel. **Circle: 250**

ACCENTS FOR ANY BUILDING...



Eye-catching spires, cupolas, dormers, roof drainage and even custom designs, CopperCraft combines old world craftsmanship with modern day manufacturing to deliver quality and excellence in every product.

Visit CopperCraft.com to put hands-on fabrication, technical expertise and customer support to work for you.

COPPERCRAFT



CopperCraft.com | 800.486.2723
Circle Reader Service #393

© CopperCraft 2017

top products of 2016

BY RURAL BUILDER STAFF

TOP ePRODUCTS from 2016

As with our Top 10 list, our Top 5 eProducts comes by crunching the numbers in the Reader Service Card system. We call it eProducts not because they are actually internet-related products but because they are presented to readers in special web-based media such as digital newsletters and online guides.

Like the magazine products, a tie resulted, so we present all six. Another RSC number is provided so if you missed getting information the first time around, you have another shot.

1. I-BEAM SLIDING DOORS



Rural Builder

I-Beam Sliding Doors is a company founded on building heavy-duty, lightweight sliding doors for the building industry. Kits come pre-punched, pre-drilled and includes all the fasteners. Also included are a military-grade latch system and the Ultra Glide Track & Trolley System. I-Beam supplies doors for new, custom and retrofit projects. Your building works when your doors work. **Circle: 251**

2. WICK BUILDINGS



Rural Builder

Wick Buildings is a leader in the post-frame industry, founded in 1954 and with more than 73,000 buildings completed. Wick builds everything from industrial and light-manufacturing facilities to banks and aviation buildings, from gas stations and churches to equine and livestock facilities and storage facilities. New in 2016 was Wick's Design-It! 3D web application. Customers can design their own post-frame building in minutes, then save and share it with friends, family, business associates and their local Wick dealer. **Circle: 252**

3. REPLICATIONS UNLIMITED



Rural Builder

The Urestone Professional Faux Stone Series represents the latest technology in large interlocking faux stone/brick panels. A key part of the product is pre-engineered wainscot panels which are typically 42 inches high x 8 feet long with a built-in 4-inch top-trim ledge. Urestone is durable, realistic and lightweight, providing energy savings, and it installs at half the cost of other systems. **Circle: 253**

4. TIE: MWI COMPONENTS



Rural Builder

In 2016, MWI added the 4400 Series Super Rail to its track and hardware line. Seeing current trends moving towards greater door sizes, MWI is working in advance by offering a line of extruded aluminum rail that is much stronger than its 3300 Series Big Frame. All sidewalls of the 4400 Series Vertical Rails are thicker for increased strength and durability, making it two times stronger; the 4400 Series Bottom Rail is four times stronger with the added features. The new line is available in lengths up to 24-foot long. **Circle: 254**

4. TIE: POWERLIFT HYDRAULIC DOORS



Rural Builder

PowerLift Hydraulic Doors is the largest hydraulic door manufacturer with more than 25 years of experience. PowerLift's manufacturing facilities build, deliver and install custom doors for aviation, industrial, agriculture and specialty projects, providing prompt local customer support. The 110 x 28 foot hydraulic door shown is on a plane hangar owned by Beck's Hybrids in Indiana. **Circle: 255**

5. PALRAM AMERICAS



Rural Builder

Palram Americas offers SunSky polycarbonate panels for daylighting applications. Palram's proprietary MetalMatch technology allows for rapid matching of existing corrugated metal profiles. Sun-Sky profiles feature co-extruded UV protection. In fact, SunSky is warranted for 10 years against loss of light transmission due to yellowing and against damage due to hail. **Circle: 256**



I-Beam Sliding Doors



Wick Buildings



Replications Unlimited

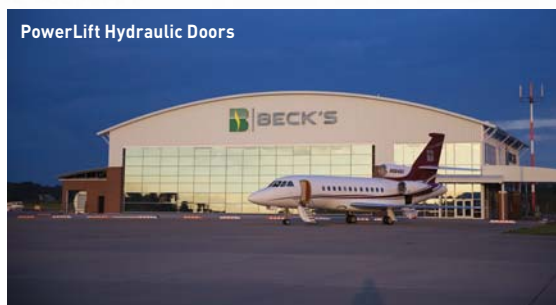

PowerLift Hydraulic Doors



Palram Americas



3300 series Bottom Rail

MWI COMPONENTS

4400 series Bottom Rail

WHY JOIN NFBA?

You can save two ways!

Save up to **60%** on Expo registration and **50%** on membership dues when you join NFBA and register for the Frame Building Expo.*

JOIN AND REGISTER

at **nfba.org** and save two ways today!

*Some exclusions apply. A company is eligible for the 50% off membership offer only if it has never been an NFBA member or has not been a member for at least 3 years. The membership discount applies only to the first year of NFBA membership dues and does not apply to PFMI assessments or to unified chapter dues in states where applicable. Visit nfba.org for more information.

Visit **nfba.org** to learn about all the benefits that NFBA membership offers.

Circle Reader Service #378

State of the Industry 2017

Signs of a Good Year Ahead

BUILDERS ARE TYPICALLY no-nonsense types who error on the side of caution, so it's no surprise that for the third straight year our annual State of the Industry survey found "cautious optimism" summing up the attitude. That caution appears to be warranted based on prevailing economic reports that paint an economy that has improved slowly but steadily since the 2007-08 recession, with outside forces that continue to temper its movement. Still, the survey uncovered more positive than negative.

VOLUME

While opinions may be tempered, the survey reveals signs of a more robust economy. Of our survey participants 41 percent said they expect to be working at about the same volume in 2017 as in 2016. Still, 32 percent are expecting a moderate increase and 23 percent are expecting a significant increase, for a combined total of 55 percent. Only 4 percent are expecting a decline.

How much work is currently in the pipeline is a good measure of how the year will stack up. More than 55 percent of the respondents reported that they have enough contracts lined up to stay busy. Of that number, 14 percent say they have enough projects to stay busy through the entire year of 2017, while 36 percent say they have enough to stay busy for six weeks, and 5 percent say they are working project to project, but are optimistic.

WORKFORCE

Despite the expected volume increase, most employers—55 percent—say they don't expect to hire additional help, 36 percent say they will hire. Nearly 9 percent are expecting to reduce their workforce.

OUTSIDE INFLUENCES

Issues that will have an influence in 2017 are varied. Of most concern to 41 percent of our survey participants is government regulation. Next in line and of equal concern (23 percent) is the employment environment and the Affordable



55%

of our survey participants are expecting a moderate-to-significant increase in business volume

Care Act. Following that were equal concerns (18 percent) for interest rates on loans, the Federal Reserve monetary policy and fuel prices. Of lesser concern was the general economy and federal budget deficit.

Drilling down to influences a little closer to home, top concerns were labor costs and compensation, followed by rising material costs, medical benefits, OSHA regulations and fears of a softening economy. Mother Nature didn't go unnoticed, with weather always a major concern for getting the job done in a timely fashion.

A LOOK BACK AT 2016

The year in review was very positive, with 68 percent of people surveyed reporting that 2016 was at least an average year if not better as compared to the preceding five years in regards to revenue. A few even said it was their best year yet. Still, 32 percent reported that it was not a good year at all in total revenue.

What general types of buildings they were constructing in 2016 is revealed in **Chart 1**.

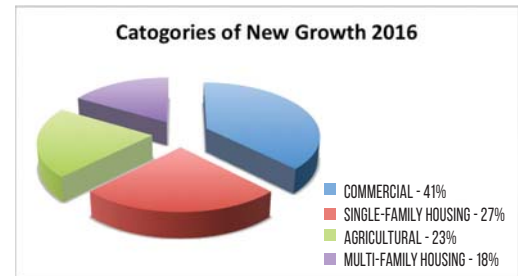

Chart 1

More diversity in building categories is anticipated for 2017 as reflected in **Chart 2. RB**

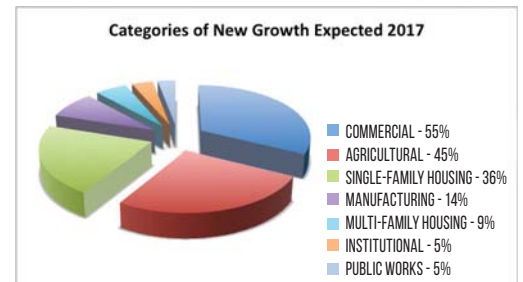

Chart 2

 **NEW!**

Whisper-Quiet, Lightning-Fast, 2nd Generation Servo Drive Technology, offering Unrivaled Productivity while consuming even Less Energy!

This patented, unique and cutting edge bending system not only offers flexibility and dramatically reduces material handling but is also capable of bending unique profiles like never before. Features a very user-friendly touch screen with high tech software that is simple and easy to understand! A superior machine at a competitive price!



A Unique Hybrid of European Design & American Manufacturing

Single & Double Benders



**HERSHEY'S
THE METAL MEISTER, LLC**
NELSON HERSHBERGER & SONS
420 PROGRESS DR. MATTOON, IL 61938
TOLL FREE: (877) 289-3030
INFO@HERSHEYSMM.COM

*Call today for more info and your free brochure!
We are here to assist you!*



**Variobend
USA**

SHEET METAL FOLDING MACHINES

Hear What Our Customers Say

Our double folder has exceeded our expectations, more than doubling our trim output. We are very happy to work with Hershey's, finally a company that has as strong a commitment to service as we do. Hershey's has been a great partner in our success. They are dedicated to customer service and innovation so that our one time purchase is a long term relationship where they continually improve their folder and increase our productivity. I cannot imagine trying any other folder, Hershey's is the last company you will ever call for a new folder.



Matt Roelfs, Owner
Iowa Steel Masters, Ackley, IA
515-689-3871

Owned a Variobend USA S2180P single folder, traded in for a Variobend USA D2188S double folder.

Circle Reader Service #536

Feedback From the Trenches

Rural Builder interviewed three individuals who provide three very distinct perspectives about the rural construction economy.

REED OSWALT, Kodiak Island, Alaska

In the great state of Alaska, the economy is not looking so great these days, according to Reed Oswalt, a now-retired sawmill owner. He is one of only about 13,500 residents living on the 3,600 square miles of Kodiak Island.

For Alaska, the issue is the declining price and quality of its oil. Once flush with cash, the state has a \$4 billion deficit. Progress is at a standstill.

Oswalt believes politicians spent too freely when times were good and never considered long-term maintenance for the things they created. “The easiest way to say it, Alaska has been on a long drunk and it finally has to sober up,” he said, adding: “We’ve had boondoggles that were beautiful—buildings built, wonderful libraries built, but no one took into consideration that these things would need to be maintained.”

The state’s problems, however, run deeper Oswalt said. On Kodiak Island, there is a cut-and-run culture for the island’s vast timber resources. Land once available publicly is now privately owned and controlled by Native Alaskan corporations set up with the assistance of the federal government. The timber is headed to China and Japan by the ship loads. “You hear the propaganda that they’re replanting, but it’s really cut and run,” he said.

When a young Oswalt struck out on his own in 1964 from Oregon with a tiny sawmill loaded on a semi, the land was still under the Homestead Act. “I came up because, where’s there’s chaos, there’s usually money,” he said. He homesteaded a 40-acre parcel, set up his sawmill and immediately had an income. “If you came to Kodiak, you came to work,” he said.

But things have changed. “Now we have people coming in here, the first thing they hit is any place where they can get anything free with no consideration for working. We have about 13,500 people here on the island. We have about 1,000 now that have applied for assistance on their food. When I was first here, that was totally unheard of.”

Today the land, the largest contiguous stand of spruce in the world, is nearly untouchable. “Our land is tied up by the federal government and by the state and then you go into a borough or county and it is very hard to tumble down through that bureaucracy to get anything opened up,” he said. “I’m glad I’m out of the sawmill business because it would have been more and more difficult to get a tree to saw, even though we’re surrounded by trees.”

Oswalt is hoping that the Trump administration will help change things. “It’s long overdue. We need someone to handle the big business of the United



■ JOB GROWTH

The Bureau of Labor Statistics (BLS) reported that the U-6 unemployment rate, (taking into account part-time workers who would prefer to work full-time, and marginally-attached workers who have looked for work in the last 12 months, but not the last 4 weeks), edged down to 9.2 percent as 2016 ended. The pool of involuntary part-time workers declined further, while the number of workers marginally attached to the labor force appears to have leveled off in 2016.

The spread between the headline unemployment rate and the U-6 rate has slipped to 4.5 percentage points. This spread has hovered between 3 and 5 percentage points during periods of high and low unemployment since 1985, but climbed to a peak of 7 percentage points during the Great Recession when the headline rate peaked at 10 percent. The decline in the U-6 rate and the spread dropping below 5 percent signal ongoing progress in reducing the hidden underutilization in the labor market.

■ HOUSING STARTS

Millennials (those under age 35) have not shown a great interest in owning homes so far, which has helped to create sluggish demand for new homes. There are, however, exceptions. According to the financial technology company, SmartAsset, here are the top 10 areas where millennials are buying homes:

- 1) Sioux Falls, South Dakota
- 2) Elk Grove, California
- 3) Bakersfield, California
- 4) Roseville, California
- 5) Peoria, Illinois
- 6) Cary, North Carolina
- 7) Fort Wayne, Indiana
- 8) Chattanooga, Tennessee
- 9) Anchorage, Alaska
- 10) Omaha, Nebraska

**FASTENER HEADS
GUARANTEED
NOT TO RED RUST!**

**HEX HEADS
LIFE-TIME
WARRANTY.**



- **EPDM Concealed Washer!**
- **Type-17 Cut Point!**



ZIMAX™
"THE LONG LIFE FASTENER"

- **H-Low™ Threads!**
- **Deep Threads for
Max Holding
Power!**

LAKESIDE™
CONSTRUCTION FASTENERS

800-537-4160

www.lakeside-fasteners.com

States as a big business because that's what it is," he said. "My hope for Alaska is that we have someone who looks at this country as a large area of resource and lot of it's renewable if it's handled properly. We're a resource country but a resource country requires people who are willing to work and want to work. That's what my hope for this new administration is, that it will bring back the fact that, if you work, you'll get paid and in more ways than one, not just monetary, but in other ways as well."

LEO SOUDER, Owner, M.P.B. Builders., Ripon, Wisconsin

Leo Souder has weathered through many phases of the construction industry since establishing his business in 1961. Diversity has helped him sway with the changes.

The past couple years have been weak for traditional agriculture buildings, once his mainstay, and he expects the same for 2017. "I would expect it will be weaker in the coming year for the ag markets, the cash guys. I think it's going to stay as weak as last year or weaker."

But vegetable farming and goat farming are exceptions. "There's a lot of people venturing into goat farming," he noted. "A lot of goat buildings are getting built for milk and cheese."

The phase may be slowing down now, he noted, but one established dairy on the southeast side of the state is building a goat complex for what he heard is about 8,000 goats.

Wisconsin is also known for potatoes and the industry is opening up to more varieties and new ways of storage that will likely bring some building demand.

While the cranberry market is down, Souder does see strength in vegetable markets. "Anyone raising vegetables is going to make money and build additions," he said.

For M.P.B., 2016 was a good one for boat storage. "It was a tremendous year," he said. "Everyone who was in the boat business was adding storage. And we've had some inquiries into the boat storage and recreational storage for this year."

Another good market recently has been mini-warehouses, but Souder sees it

moving into a new phase: larger storage buildings and climate-controlled storage. "I think that's an expanding market" he said.

Still strong are hobby shops with living quarters, a trend that has been strong for a couple years.

Souder believes a good builder should have a good year. "People heavy in the ag markets are going to suffer a little, but a good share of builders are diversified," he said. "We do everything possible from billboards to bridges, so the average builder, if they have a track record of a lot of buildings out there, there's going to be repair work and re-roof work. I think it's going to be a positive year."

MIKE MOMB, Technical Director, Hansen Pole Buildings, Browns Valley, Minnesota

Like our survey results, Mike Momb is cautiously optimistic about 2017. While 2016 was a boom year for the company, the year ahead is uncharted territory politically for the country.

"We have the first non-professional politician as president since Ike, who should lead a pro-business climate," he said, predicting: "Other than support structures along the Mexico-U.S. border, expect governmental expenditures for buildings to be down."

Ag will also be down. "Farmers had a bumper crop in 2016, which has led to mountains of grain stockpiled in the Midwest, with nowhere to go as the strong U.S. dollar makes exports more problematic. With prices down, I won't expect the true ag market to be lucrative this year.

"Markets which should be strong will be housing—both single and multi-family, health care (especially as related to the elderly) and education, as many states are mandating smaller student/teacher ratios," said Momb.

It is controversial, and you may not wish to participate, but Hansen Pole Buildings has been fielding inquiries from the marijuana industry. "The burgeoning marijuana industry is going to be huge as they need buildings for grow operations, packaging and shipping as

well as retail outlets," said Momb.

Like others, Momb sees the lack of quality help as a major problem. "Unemployment rates are low and most of those who have dropped out of the job search market are frankly either under educated or not truly interested in working," he said. "Automation and outsourcing are parts of the immediate solution, along with utilization of more prefabricated building components."

Another persistent problem are burdensome regulations. "Areas which require structural plan reviews are getting more and more onerous and those jurisdictions require a special degree of patience to do business in successfully," he noted.

Momb does see an optimistic future for post frame. "Post frame reduces construction costs by elimination of much of the cost of continuous concrete footings and foundations, allows for work to be done by most DIY new homeowners and affords greater flexibility in designs, open-floor plans and energy savings. In my humble opinion this will increase as post-frame builders embrace housing, promote it as a viable option and permitting jurisdictions become more comfortable with post-frame buildings as a design solution."

Because Hansen sells post-frame building packages, Momb talks to builders on a regular basis. What are they telling him?

"Most of the builders I talk to are ones who are the technicians—they drive nails and screws personally. All of the good ones have more work than they know what to do with and cannot find enough reliable help. They continue to increase their prices and are getting what they ask for and their clients will wait patiently for months for them to build.

"On the flip side are the ones who do questionable work, and work only a week or so a month. They've ridden the wave of the higher prices charged by the good builders, however the poor quality of their workmanship and lack of a work ethic drive their clients crazy. Both groups seem quite positive about their ability to earn." **RB**

We stock
100% Made
in the USA

Specialty Painted Nails!

- Color matched nails save time and labor on prefinished jobs
- Engineered for both face and blind nailing applications
- Available in double hot dip galvanized coils, collated sticks and hand drive
- Hammer caps included with each 5-lb. box of hand driven nails to reduce paint chipping



Designed for the following companies:

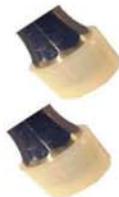

5-lb. boxes of 8d (2-1/2") painted, hand-driven nails are kept in stock - 6 boxes per case.

If the installer prefers MAZE coil nails or MAZE stick nails for pneumatic nailers, we can paint those nails too.



Circle Reader Service #306

Contact us for details on MAZE Painted Nails today!
800-435-5949 • mazenails.com

new products at the expo

BY RURAL BUILDER STAFF

Gotta'-Have-It Solutions for Rural Builders

ONE OF THE FUN THINGS ABOUT THE FRAME BUILDING EXPO IS THE INTRODUCTION OF NEW PRODUCTS FOR EVERYONE TO SEE.

It's always popular. If you go, here is a look at a few of the products that are being rolled out. If you don't go, here's a look anyway.

For more information contact the companies. A reader service number is supplied to use for that purpose. The card is located between pages 58 and 59. Fill it out, send it in and the companies will be informed that you are awaiting information. **RB**



LONG-LIFE FASTENER SOLUTIONS FROM LAKESIDE

Lakeside Construction Fasteners will showcase its ZMAX Long-Life and SC SteelGuard at the expo.

ZMAX alloy fasteners are engineered for corrosion applications. They offer a larger outer diameter to prevent wind uplift and are suitable in snow-load regions. They are also ideal for coastal environments, preventing red rust on fastener heads once properly installed into metal buildings.

For a lower-head profile, Lakeside has introduced the ¼ HWH Long-Life SC Steel Guard. The engineered flat-head service prevents fastener wobbling during installation. These fasteners have a larger outer diameter with a ¼ HWH to prevent wind uplift and are also suitable for coastal regions where the stainless steel fastener head won't red rust for the life of the metal panel.

Both the ZMAX and SC Steel Guard are available in #10 x 1 - 3 inches. They have high-low threads for maximum holding power and can be used with either battery-operated or impact screw guns. **For more information circle 159.**



SIDING AND TRIM FROM BORAL

Boral is introducing two new innovative options that will change the way you look at exterior products—Boral TruExterior Siding & Trim and Boral Versetta Stone.

Made from the revolutionary new poly-ash material, TruExterior Siding and Trim solve both the moisture- and movement-related issues commonly seen with other exterior materials, while offering a balance of performance and aesthetics.

Versetta Stone is a mortarless, cement-based manufactured stone veneer with a unique, panelized design. It is installed with mechanical fasteners, allowing carpenters and contractors to re-create the beauty and craftsmanship of authentic stone masonry using nails or screws, offering a complete system founded on quality, speed and selection.

For more information circle 116.



Your Buildings are Your *Legacy!*

Ensure they withstand the test of time!

Your buildings are your legacy and inferior substrates, paint coatings and outdated manufacturing processes from your supplier can blemish your reputation. Strengthen your Legacy with McElroy Metal!

Your
Legacy



EDGE-RUST INHIBITOR

A clear-coat rust inhibitor is factory-applied to the cut ends of Post Frame panels. This inhibitor deters rusting of the exposed edge.



Environmental tests show extensive corrosion along cut end of panel without Edge-Rust Inhibitor.



Minimal corrosion is detected along cut end of panel with Edge-Rust Inhibitor.

KYNAR 500® (PVDF) PERFORMANCE AND AESTHETICS for the Long Run!

Day one, colors were the same. 8 years later, note the fading and chalking of the Siliconized Polyester.

Kynar 500®

Siliconized
Polyester

The McElroy Metal Difference:

- Galvalume® Substrate
- Kynar 500® (PVDF) Coating
- Factory Applied Edge-Rust Inhibitor
- All 29 Gauge Painted Coil Made in the USA
- Warm Forming on SMP Panels

For more information:

www.mcelroymetal.com • info@mcelroymetal.com

Circle Reader Service #422

new products at the expo

BY RURAL BUILDER STAFF



A NO PRE-DRILL SCREW FROM SIMPSON STRONG-TIE

Simpson Strong-Tie has launched the Strong-Drive SDWH Timber-Hex HDG screw. The fastener requires no pre-drilling and replaces bolt, washer and nut assemblies, saving installers time and cost. It is specifically designed to resist severe corrosion levels in heavy-duty marine and coastal applications, such as piers, boardwalks, structural pilings and docks.

The .276-inch diameter hot-dip galvanized screw features a SawTooth point and oversized integral washer which eliminate the need for pre-drilling and a separate washer.

The SDWH Timber-Hex HDG screw is available in five lengths, ranging from 4- to 12-inches and features a 3/8-inch hex-drive head for secure driving.

For more information circle 217.



INLINE VENTED AG PANEL FROM BRADBURY

With the addition of the Bradbury lancing pass, an ag panel rollformer can produce vented soffit inline. This eliminates the need for special coil stock and adds the ability to produce Grade 80 steel soffit from multiple color coils in inventory. Inline production of vented soffit means no double handling of the panels. When equipped on a post cut machine, the production of short sheets from coil can be ran without the need for an offline shear. Engaging the venting pass is a simple adjustment of a screw jack on the last station of the machine. **For more information circle 118.**

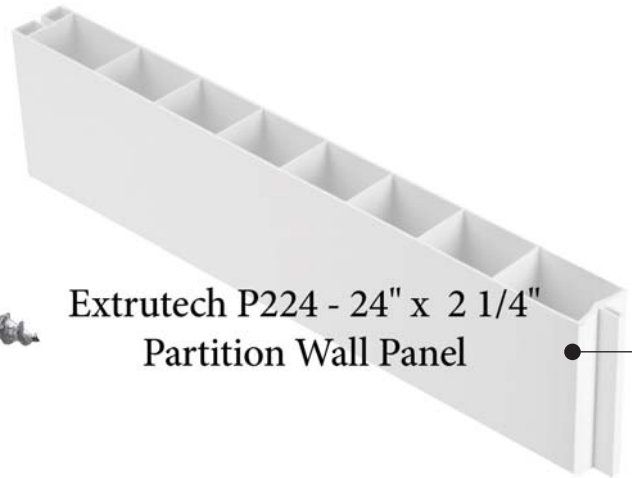

Extrutech P224 - 24" x 2 1/4" Partition Wall Panel

INTERIOR PARTITION PANEL AND TRIM FROM EXTRUTECH

Extrutech Plastics Inc. will be introducing its new P224-24-inch partition wall panel and trims. Also being added are several new profiles to enhance its concrete form wall system, which will make it more builder friendly.

Extrutech has also developed some new exciting colors for its panels and trims that will be on display. All products are made in Wisconsin. **For more information circle 136.**

FEATHERLIGHT REFLECTIVE INSULATION FROM MARTIN BUILDING PRODUCTS

VerSola Aluminum Double Bubble White Poly Reflective Insulation is featherlight and a mere 5/16 inches thick, yet it blocks up to 95 percent of radiant heat transfer. A double layer of insulating bubbles is encased between a layer of highly-reflective, 99 percent pure aluminum and a layer of titanium white polyethylene film. The aluminum layer repels summer sun, the white layer reflects light for a brighter interior. The air in the bubble layer serves as an effective thermal break between surfaces, while the outer layers form a moisture/vapor barrier. The result is a healthier, more comfortable and energy-efficient space. **For more information circle 167.**



SINCE 1951



ONE WORD IN CONSTRUCTION EXCELLENCE

Since 1951, one word in the post frame and commercial construction industry has become synonymous with quality products and excellence in customer service – **PLYCO**. Plyco continues to stand by you and their commitment to providing a full line of products that surpass building codes and customer expectations. **Build PLYCO Strong**



PLYCO

CORPORATION
Elkhart Lake, Wis.

www.plyco.com • 800.558.5895

WINDOWS • WALK DOORS • WALL VENTS • RIDGE VENTS
SLIDING DOOR TRACK • SLIDE DOOR RAILS • PLY-FOIL INSULATION
HORSE STALLS • FASTENERS & CLOSURES • SPECIALTY PRODUCTS

NFBA
BUILDING OF THE YEAR
Supplier



new products at the expo

BY RURAL BUILDER STAFF



PUSHALL MULTI-PURPOSE TOOL FROM AG-CO

The PushAll Multi-Purpose Tool is the smarter choice when it comes to snow removal. It has an ergonomic U-shaped handle, rounded corners and a flat edged blade that utilizes your body's strength to do the work. No need to lift, just push. It will easily glide over cracks and seams and is ideal for driveways, stairs and sidewalks and holds up to 2300 cubic inches of materials per pass.

For more information Circle 102.

NEW DOOR LINE FROM SAFE-WAY

Safe-Way Door has added a new door to its lineup of high-density polyurethane insulated garage doors. Combining ruggedness and good looks with the benefit of an R-Value of 17.68, the new Ambient line is geared toward residential, commercial and industrial applications where superior insulating ability is desired. The high-density polyurethane core is credited with giving the Ambient line superior insulation properties, along with more strength for better performance and durability.

For more information circle 210.

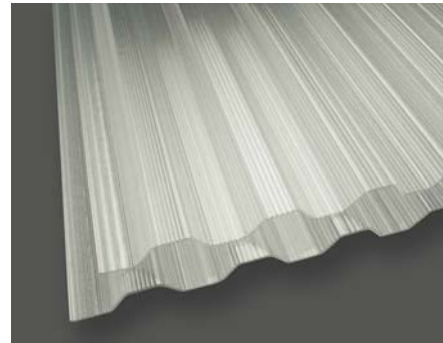

POLYCARBONATE CORRUGATED AND MULTI-WALL PANELS FROM RESOLITE

Since 1951, Resolite FRP Composites has been in the forefront of new product development in fiberglass reinforced plastic panels. Resolite designed the first fire-retardant fiberglass reinforced plastic sheet and introduced the first walkable FRP panel. Resolite is now offering a new line of Makrolon polycarbonate corrugated and multiwall panels. The corrugated panels were specifically designed for metal buildings as skylights and sidelights. These polycarbonate corrugated sheets match most of the metal panel profiles in the U.S. market. **For more information circle 204.**



INTRODUCING INTERIOR SLIDING DOOR HARDWARE SATIN NICKEL KIT



**Visit Us at Booth #720 for a Chance
to Win an Interior Sliding Door Kit!**

Perfect for bedrooms, bathrooms and other living spaces

Offered in oil rubbed bronze

Designed and tested to follow ANSI/BHMA Grade 1 standards

Kits include 72" track, hangers, doorstops, anti-jump discs and floor guides

IT'S THE *Little Things*™

**National
Hardware**®



www.natman.com
Circle Reader Service #540

113946_SN 1216

Expo Exhibitors

Meet these companies, see their products, in Nashville

The Frame Building Expo returns to its favorite venue this year—Nashville. And, it's a special occasion: the 50th exposition for post-frame builders.

The event, which has been known by several different names throughout the years, was started in 1967 by Roy Reiman, the founding owner of *Farm Building News* (also started in 1967 and later renamed *Rural Builder* magazine). The NFBA took part in the annual event, later establishing its own annual conference before the two events combined in the mid-1990s. It continues to be a shared endeavor.

Here is a run-down of the companies preparing to exhibit at the trade show and some of the products they'll bring along. As always, *Rural Builder* will be there too.

To attend the show, register online at nfba.org. If you can't attend, contact these companies and ask them about their products. **RB**



3GM STEEL INC.
Booth 714 / Circle 100

3GM Steel Service Center provides quality pre-painted and bare products for your metal roofing requirements. Ask for a detailed description of items including color, gauges and widths that are inventoried and ready to ship.

A.B. MARTIN ROOFING SUPPLY LLC
Booth 508 / Circle 101

A.B. Martin Roofing is a manufacturer of quality metal roofing and siding panels including the ABM multi-purpose panel, the ABSeam standing seam panel, and the PBR commercial panel. A.B. Martin provides building materials for pole buildings, including framing lumber, insulation, doors and windows, tongue-and-groove lumber, horse stalls and much more.

AG-CO INC.
Booth 130 / Circle 102

FootingsPad replaces concrete footings of equal diameter. This unique and lightweight product is designed to help raise post-frame buildings in record

time. FootingsPad's patented technology evenly distributes post loads and saves hours of backbreaking work while meeting the ICC-ES building code acceptance criteria (AC49). FootingsPad is ICC code compliant and provides durability and strength. "Save time. Less mess. Less hassle."

AGCOR STEEL
Booth 449 / Circle 103

Agcor Steel is one of the Southeast's premier manufacturers of metal building components. Agcor manufactures metal panels for any residential, agricultural, commercial, industrial or roofing application. Agcor also has everything for a post-frame structure, from post to metal or wood trusses to roofing and siding. Agcor saves you time and money by delivering the components you need directly to your site. New distributors are welcome.

A.J. MANUFACTURING INC.
Booth 618 / Circle 104

A.J. Manufacturing's 4-way universal steel frame, composite frame and aluminum frame doors with steel, fiberglass or aluminum panels will be on display in Nashville. A.J. builds Harmony and Main Street vinyl windows designed for the post-frame industry with Nailing Fin, 1-inch J-Channel or EZ-v vinyl trim and flashing. A.J. has a commitment to building ideas and providing its customers and the post-frame industry the highest value solutions.



A.J. MANUFACTURING INC.

AKZO NOBEL COATINGS INC.
Booth 503 / Circle 105

AkzoNobel manufactures high performance coil coatings for the pre-painted metal construction industry, serving the commercial, agricultural, architectural and residential markets. Coil coating products include Trinar, a 70 percent PVDF coating, and Ceram-A-Star1050, which is the



AKZO NOBEL COATINGS INC.



A.B. MARTIN ROOFING SUPPLY LLC

Cool color.
Cool impressions.
Cool savings.



Save energy costs with cool protective coatings that create a colorful, lasting impression. With the highest solar reflective (SR) pigments in the industry, Valspar decreases environmental impact by increasing energy efficiency. Lower energy costs without sacrificing durability, performance or beauty. Call 1-888-306-2645 to speak with an expert, or visit us at valsparcoilextrusion.com/greenagenda.

valspar®

Circle Reader Service #484

expo exhibitors

BY RURAL BUILDER STAFF

industry-leading silicone-modified polyester coil coating. Both are available in Cool Chemistry formulations, which help make projects more energy efficient and sustainable.

ALPINE DISTRIBUTION

Booth 711 / Circle 106

Alpine Distribution is a coil distributor providing competitively-priced domestic and import-quality steel with reliable, consistent and caring service from knowledgeable experienced industry veterans. Alpine will establish customized stocking programs in acrylic and painted galvanized, Galvalume or aluminum in any metal or paint specification. Alpine also can provide slit, c-t-l, embossed coil products.

AMARR / ENTREMATIIC

Booth 337 / Circle 107

Established in 1951, Amarr is one of the world's leading brands in design, manufacturing and distribution of sectional doors for residential and commercial applications. Made in the USA, Amarr products have a legacy of innovation and high quality design. Amarr is a part of Entrematic, a company comprised of well-established entrance automation brands with nearly 200 years of cumulative experience. Entrematic provides one of the world's most complete ranges of entrance automation products and warehouse solutions.

AMERIPAK STRETCH WRAP SYSTEMS

Booth 442 / Circle 108

Ameripak Stretch Wrap Systems is the manufacturer of Ameripak Horizontal Stretch equipment designed specifically for unitizing and protecting metal wall and roof panels, standing seam panels, metal molding and trim. With the ability to talk or "handshake" with most roll-forming equipment, Ameripak horizontal wrappers increase efficiency and output by speeding up the forming line's packaging process. Ameripak horizontal wrappers are in use by many of the nation's leading metal-forming companies.

AMERICAN BUILDING COMPONENTS

Booth 513 / Circle 109

Tirelessly committed to delivering quality products and exceptional service, American Building Components has built a strong reputation of providing premium metal roofing and building solutions that customers have relied on for more than a century. Servicing primarily the residential, commercial, post-frame and agricultural markets, ABC offers a wide variety of premium metal panels in both 29- and 26-gauge steel, as well as roof and wall accessories, including structural products, fasteners and trim that are second to none.

ASC MACHINE TOOLS INC.

Booth 607 / Circle 110

ASC has been serving the metal-forming industry exclusively as a machinery engineering and manufacturing company for more than 60 years. ASC specializes in roll-forming machinery for panel, trim, purlins and custom-designed profiles.

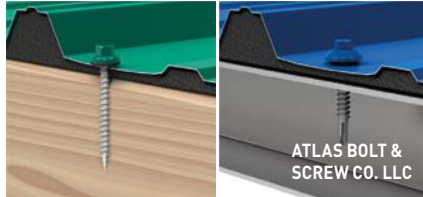

ATLAS BOLT & SCREW CO. LLC

Booth 225 / Circle 111

Atlas Bolt & Screw is an industry leader with a wide selection of metal and wood fasteners, closures, venting, sealing and flashing solutions. Headquarters and U.S. manufacturing are located in Ashland, Ohio, with secondary manufacturing and fully-staffed service facilities strategically located in Houston, Texas; Salem, Oregon; and Flat Rock, North Carolina. Atlas Bolt & Screw provides its partners longevity of proven performance, extreme customer focus, a vertically-integrated supply chain, an innovation heritage and future; and industry leadership.

BAY INSULATION SYSTEMS

Booth 232 / Circle 112

Bay Insulation Systems is one of the nation's largest suppliers of insulation for the post-frame industry. Products include faced fiberglass, unfaced fiberglass up to 96 inches wide, a full line of insulation accessories, reflective insulation, Thermax rigid insulation, Baylight prismatic skylights and Expi-Door walk doors with fire-rated and high-security features.



THE BECKERS GROUP

Booth 632 / Circle 113

The Beckers Group is a privately-owned international coatings group with a leading position in its markets worldwide. Sustainability, design and innovation are an integral part of its long history spanning 150 years. As a leading worldwide supplier of coil coatings, Beckers has an international organization that ensures global coordination and consistent product standards. Known for setting industry standards for high-performance, Beckers products are in use all over the world. Among its many innovations is the award-winning BeckryTherm, an energy-saving coatings system available in super-durable polyester, silicone polyester and PVDF.



BEST PRODUCTS

Booth 539 / Circle 114

Since 2004 Best Products has been manufacturing Perma-Columns to builders desiring the most cost-effective concrete foundation for their buildings. The product line continues to expand with more options that customers have come to expect: concrete columns of various sizes and lengths, Sturdi-Wall concrete anchor brackets for most any column size, foundation pads and laminated wood columns.

BEST LINE BUILDING PRODUCTS

Booth 630 / Circle 115

Best Line is an Illinois-based company specializing in soffits, rainware and accessories made to be perfect matches for roof and wall panels.

BORAL Booth 149 / Circle 116

Boral will be displaying two new innovative options for exterior products—Boral TruExterior Siding & Trim and Boral Versetta Stone. Made from the revolutionary new poly-ash material, TruExterior Siding & Trim solves both the moisture- and movement-related issues commonly seen with other exterior materials. Versetta Stone is a mortarless, cement-based

manufactured stone veneer with a unique, panelized design that is installed with mechanical fasteners, allowing carpenters and contractors to recreate the beauty and craftsmanship of authentic stone masonry using nails or screws. Boral offers a complete system founded on quality, speed and selection.

BORKHOLDER BUILDINGS AND SUPPLY Booth 230 / Circle 117

For more than 50 years, Borkholder Buildings and Supply has been providing post-frame buildings. In its Midwest dealership program, it provides building packages including engineering and professional design. Unique and innovative truss production ensures that your building will be at a high-quality level. Borkholder has also developed high-energy-efficient homes and buildings such as Net Zero Energy Homes.

THE BRADBURY GROUP Booth 519 / Circle 118

The Bradbury Group of companies make an extensive line of roll-forming equipment including panel and trim roll formers, folders, slitters, and recoil lines for the production of trim, gutter



BORKHOLDER BUILDINGS AND SUPPLY

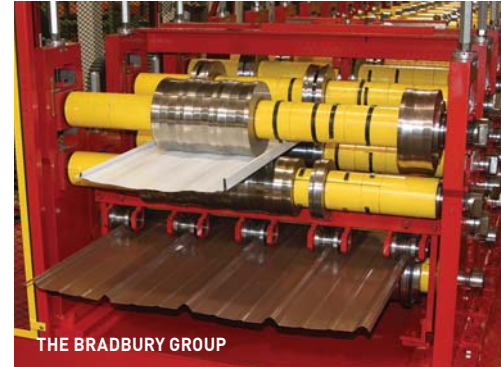

THE BRADBURY GROUP



ONE CALL - ONE LOCATION FOR ALL THINGS POST FRAME!

RESIDENTIAL



COMMERCIAL



- Metal Roofing
- Trims
- Lumber
- Pre-Engineered Trusses
- Laminated Posts
- Insulation
- Timely Delivery
- All Accessories

FARM & AG



EQUINE

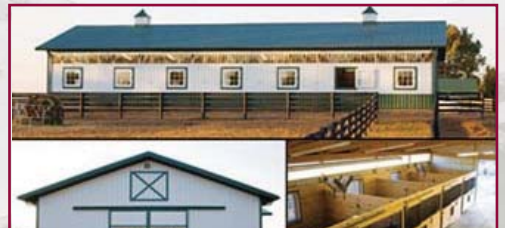

CONTACT US ABOUT JOINING OUR NETWORK OF WHOLESALE DEALERS!

Providing excellent service since 1973

Graber Post Buildings, Inc., 7716 N. 900 E., Montgomery, Indiana 47558

800.264.5013 | Fax 812.636.4936 | www.graberpost.com



Circle Reader Service #433

expo exhibitors

BY RURAL BUILDER STAFF



THE BRUT POST GRABBER

machines, insulated panel lines, and turnkey metal tile/shingle plants. It offers equipment options for the startup producer as well as the established manufacturer. Bradbury is known for cutting-edge technology and reliability built into every product.

THE BRUT POST GRABBER Booth 415 / Circle 119

Never manhandle heavy posts again! The Brut Post Grabber skid steer attachment makes easy work of post placement. This innovative attachment was designed and developed by a post-frame building contractor. The Brut solves problems of safety, physical strain and hole sloughing. And, it's made in the USA.

BULLINGTON LUMBER & TREATING Booth 700 / Circle 120

Bullington Lumber & Treating provides different lines of industrial and residential southern yellow pine lumber. At Bullington you will find its services, prompt deliveries, competitive prices, and a variety of machinery makes it a "one-stop shop" and the reasons Bullington is one of the oldest lumber companies in the Southeast. Along with its precision-milled timbers, the company offers on-site treating and can assist in managing your inventory by mixing shipments on individual loads.



THE ONLY ONE-STEP FASTENER!

for fiberglass or PVC panels!

Master One-Steppers® are the only time-saving one step screws for attaching panels that exhibit thermal expansion to wood frame structures. The revolutionary patented design self-drills an expansion hole, automatically centers, drives in and provides a cushioned expansion-seal in ONE STEP! No pre-drilling. No panel cracking!

Master One-Steppers® are available in 304 and 410 stainless steel, or in carbon steel with Leland's renowned long-life platings and powder coatings. Find out more today!



Toll Free: 1-800-263-3393
www.lelandindustries.com
Demand North American Quality!

Circle Reader Service #341

Hexavalent Chromium Free!
It's the law.

BURROW'S POST FRAME SUPPLY
Booth 663 / Circle 121

Grow your share of the suburban post-frame market with a complete range of Burrow's-manufactured wood trusses, metal roofing, metal siding, lumber and accessories. Having started out as a leading post-frame construction company, Burrow's prides itself in being stubborn about quality in everything it does and centered on being a value-driven, business-building supplier resource that provides builders a true competitive edge.

CANNONBALL:HNP
Booth 231 / Circle 122

CannonBall:HNP is a leading supplier of components for the post-frame and metal building industries. Since 1916, CannonBall has offered the most complete line of round track products and accessories, including industry-standard Keyhole Track and Quick Track. The wide variety of entry doors are manufactured with versatile design and affordable pricing for the agricultural, commercial and metal building markets. Builders also rely on CannonBall for quality Dutch doors, cupolas, horse stalls, windows, builders' hardware and more.

CAPITAL FOREST PRODUCTS
Booth 514 / Circle 123

Capital Forest Products has been successfully marketing lumber products for more than 30 years and is proud to be one of the nation's largest stocking distributors of Eastern White Pine, SPF and SYP. It attributes its growth to intimate relationships with both customers and specialty mills and the company is positioned to service a variety of accounts. Capital is also a stocking distributor of all Titanium synthetic roofing underlayments including Rhino Roof.

CENTRAL STATES MFG. INC.
Booth 401 / Circle 124

Central States manufactures metal building components for the post-frame, light-gauge, architectural, residential and commercial markets. Offerings include both exposed and concealed fastener panel profiles, as well as trapezoidal standing seam panels in a selection of gauges, colors and warranties. Trim and purlins are also available. Complete mini, boat and RV storage packages are available through the Central Storage Works division.

C.H.I. OVERHEAD DOORS
Booth 315 / Circle 125

If you are in the market for a residential, commercial or rolling-steel overhead door, look no further than C.H.I. Overhead Doors. The company, through its commitment to quality and value, recognizes the importance of delivering a reliable product. C.H.I. offers an impressive selection of models in a wide range of sizes so you can find a garage door to match your exact specifications.



CUSTOM PRIVATE LABELED PRODUCTS

In-House Art Department and Custom Literature & Label Printing



ELASTOMERIC WATERPROOFING INSULATING CERAMIC ROOF COATINGS • ZERO V.O.C. INSULATING CERAMIC INTERIOR & EXTERIOR PAINTS • ELASTOMERIC CERAMIC WALL, TEXTURE & INDUSTRIAL COATINGS • CONCRETE & DECK PAINTS, STAINS, CLEAR COATS & SEALERS • WOOD STAINS, CLEARS & DECK-OVER COATINGS EPOXIES • COLOR MATCHING & CUSTOM FORMULATIONS



CALL TODAY FOR A FREE PRIVATE LABEL CONSULTATION!



NATIONWIDE PROTECTIVE COATING MANUFACTURERS, INC.

1.800.423.7264 941.753.7500

www.nationwidecoatings.com



Member Since 1997



FRAME
BUILDING
NEWS

Happy 50th

SHEAR-

BOOTH #
531

AkzoNobel 

BOOTH #
503

aj

BOOTH #
618

CANNONBALL

BOOTH #
231

PALRAM

BOOTH #
631

DAYSTAR
High Performance Natural Lighting Systems

BOOTH #
702

THERMAL
3^{HR}
ALL-WEATHER
SHIELD

BOOTH #
326

ASC ASC MACHINE TOOLS, INC.
MAKING THE FUTURE OF PERFORMANCE TOOL

BOOTH #
607

DMI
DIRECT METALS INC.

BOOTH #
701

Beckers

BOOTH #
632

LAKESIDE
CONSTRUCTION FASTENERS

BOOTH #
412

ATLAS
Fasteners For Construction

BOOTH #
225

BRADBURY
THE BRADBURY CO., INC.

BOOTH #
519

MIDWEST PERMA-COLUMN
BEST
PRODUCTS

BOOTH #
539

BIP

BOOTH #
127

MAC
METAL SALES

BOOTH #
312

Master Distributor
FASCO
AMERICA

BOOTH #
320

K & K
INDUSTRIES INC.

BOOTH #
115

LELAND
INDUSTRIES INC.

BOOTH #
501

m
comp
BUILT FOR



Anniversary!

Rural Builder

BUILDING
PO
2017
YEARS

BOOTH # 542
Everlast Roofing, Inc.
OUR NAME SAYS IT ALL

BOOTH # 726
DYNAMIC FASTENER

BOOTH # 343
POWERLIFT
HYDRAULIC DOORS

BOOTH # 700
B
Bullington Lumber & Treating

BOOTH # 413
PERMA COLUMN

BOOTH # 733
MARION MANUFACTURING

BOOTH # 401
CENTRAL STATES MANUFACTURING, INC.
METAL BUILDING COMPONENTS

BOOTH # 221
NOVAGARD Solutions.
Engineered Products... Innovative Thinking

BOOTH # 215
PPG

BOOTH # 201
PLYCO

BOOTH # 512
valspar

BOOTH # 313
RICHLAND
LAMINATED COLUMNS LLC

BOOTH # 243
VALLEY
Lumber Company, Inc.

BOOTH # 123
US Steel TRUSS
STANDING STRONG

BOOTH # 224
TRI-STATE LUMBER CO.

BOOTH # 319

wi
POST FRAME

BOOTH # 309
MCELROY METAL

BOOTH # 613
Precoat Metals

BOOTH # 109
ST Fastening Systems

BOOTH # 726
DYNAMIC FASTENER

expo exhibitors

BY RURAL BUILDER STAFF

CIDAN MACHINERY

Booth 110 / Circle 126

CIDAN Machinery offers a complete line of metal forming devices. Whether you're looking for capacity, utility, flexibility, efficiency or economy, CIDAN has a model that fits your needs.

COMBILIFT USA

Booth 719 / Circle 127

The Combilift range of 4-way forklifts was designed for the safe and space-saving handling of long and awkward loads. Robust design and super elastic tires enable it to work both inside and out, on semi-rough terrain and in all weather conditions. Capacities range from 2.5 to 25 tons with diesel, LPG or electric-battery power available with a variety of attachments to cater to individual customer requirements.

DAYSTAR SYSTEMS LLC

Booth 702 / Circle 128

Utilizing unique technology, DayStar developed a completely-natural lighting system for commercial applications, such as clinics, municipal buildings, schools, hangars, big box retail stores, manufacturing plants and



COMBILIFT USA

warehouses. Directed through an ultra-reflective shaft, natural light is amplified and dispersed evenly, regardless of the size of the building, even on cloudy days. With more uniform diffusion, no glare and hot spots, DayStar's system also

extends the amount of hours electric lights can be turned off, up to 9-1/2 hours per day, maximizing energy savings. Aesthetically appealing in open environments, the super-insulated light shaft requires no attic support walls and is available in custom lengths. DayStar's complete system includes dome, light shaft, insulated steel or aluminum roof curb to match your roof pitch and rib design, and ceiling lens. All units are powder coated to match your roof color.



DBCI Booth 727 / Circle 129

DBCI is a leading manufacturer of steel curtain roll-up doors for the commercial and self-storage markets. With field technicians and manufacturing and sales offices across the U.S., DBCI quickly and efficiently delivers superior products and services. Its doors are designed and manufactured with a focus on integrity, quality and longevity, and our people ensures its products and services meet your ever-changing



ROLL FORMING EQUIPMENT

MANUFACTURER OF METAL FORMING EQUIPMENT, FOR COMMERCIAL AND RESIDENTIAL CONSTRUCTION USE, USING D2 TOOL STEEL FOR LONGER WEAR LIFE, AS A STANDARD, NOT AN EXTRA COST.



AG PANEL

CORNER

HEMMER

SLITTER

UNCOILER

RIDGE CAP



10550 TR 262, Millersburg, OH 44654
Phone (330) 674-4003 Fax (330) 674-4035

J CHANNEL

RAT GUARD

WRAPPERS

TRIM WRAPPER

POST CUT SHEARS

ROLLS AND TABLES

needs—ultimately making DBCI doors among the most durable and reliable in the industry.

DIRECT METALS INC.

Booth 701 / Circle 130

Direct Metals Inc. is a manufacturer and master distributor of many products for the post-frame building market including fasteners, flashings, insulation, ridge vents, closures, sealants, windows, doors and door hardware. Its American-made products such as Razorback Ridgeback and standing seam metal roof clips are now in stock at the Plymouth, Indiana, Midwest Service Center. Visit the booth for a catalog.

DURA COAT PRODUCTS

Booth 737 / Circle 131

Dura Coat Products specializes in quality coatings that provide a high ROI for commercial, farm and residential uses. Ceranamel XT-40SMP is a proprietary polyester that provides hardness combined with flexibility that is significantly more abrasion- and strain-resistant than conventional coatings. Ceramic pigmentation prompted the name. Ceranamel has excellent weathering and fade resistance properties. Durapon 70 is a PVDF



formulation equal to or better than any coating on the market. It has excellent weathering qualities, is flexible enough to handle post-forming operations and displays excellent resistance to installation scratching, scuffing and transit abrasion. Both coatings are energy efficient and meet Energy Star standards.

DYNAMIC FASTENER

Booth 726 / Circle 132

Dynamic Fastener offers same-day shipping of screws, anchors, flashings, safety equipment, hand tools and power tools, as well as in-house painting of screws and rivets, with one- or two-

day lead time. The company's free 132-page, full color, tool and fastener hand guide provides engineering data and details product offering. Locations include Kansas City, Missouri (Main Office), Chicago, Houston, Las Vegas, Memphis, St. Louis and St. Paul.



EAST COAST FASTENERS

Booth 308 / Circle 133

East Coast Fasteners produces durable, long-lasting fasteners for all combinations of building materials. For fastening wood, aluminum, steel or any variety of applications, East Coast's fastener line is manufactured to superior quality standards to guarantee optimal performance. With a variety of coatings to assure the builder has the best product on the market and the fastest cutting tips, East Coast fasteners are manufactured to standards that assure fast and reliable installation every time. East Coast Fasteners provides the

We can take any ribbing and make light of it.

Match virtually any custom profile with SunSky in days.

Get the leading corrugated polycarbonate delivered fast to fit most any metal profile with SunSky® MetalMatch™ technology. So you can add value and more daylight to projects in as little as two weeks. And MetalMatch is available at an extremely attractive price.



More daylighting options. More easily.

SunSky's first-in-class durability, high performance and superior light transmission are ideal for roof, side and skylight applications. So you can expand unique design possibilities, reduce energy costs, and enhance environments with more natural light. Available in several opacities,



including Soft White, SunSky is backed by a 10-year warranty. To learn more, contact your local distributor or call 800-999-9459. Or visit us at www.PalramAmericas.com/MyProfile. We'll take the perfect ribbing and make it even better.



Circle Reader Service #350

expo exhibitors

BY RURAL BUILDER STAFF



EAST COAST FASTENERS

strongest and most effective fasteners for your construction needs. For assistance in finding the best fastener, contact a Plyco/East Coast Fasteners building component professional.

ENERGY PANEL STRUCTURES

Booth 537 / Circle 134

Energy Panel Structures specializes in pre-engineered buildings and tilt-up panel systems

for all types of construction. Since 1981 EPS has offered only the best building designs in commercial, agricultural, residential and cold storage that are manufactured in Iowa, Missouri and New York.

EVERLAST ROOFING INC.

Booth 542 / Circle 135

Everlast Roofing is proud to have become an innovator in its field, with a promise to its customers to continue to push boundaries in producing a superior-performing product. This promise has led to the introduction of AZM with Activate Technology and ColorBond with the release of Everlast's next-generation product. Backed with a 20-year proven record of outperforming accelerated laboratory and real-world, harsh-environment exposure tests, Everlast Roofing is the only company to offer this technology in North America. Offering a variety of gauges, colors and custom trims to suit every customer's application makes Everlast Roofing the perfect choice for the agricultural, commercial and residential markets.

EXTRUTECH PLASTICS INC.

Booth 209 / Circle 136

At the 2017 Frame Building Expo, Extrutech Plastics

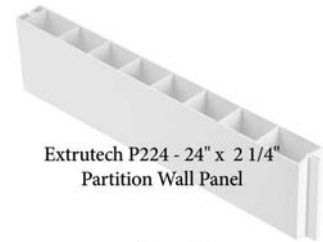

Extrutech P224 - 24" x 2 1/4" Partition Wall Panel



EXTRUTECHFORM® System

Inc. will be introducing its new P224, 24-inch partition wall panel and trims. Also being added are several new profiles to enhance the Extrutech concrete form wall system, which will make it more builder friendly. Extrutech has also developed new exciting colors for its panels and trims that will be on display. All products are made in Wisconsin.



RICHLAND

LAMINATED COLUMNS LLC

"Your One Stop Pole Shop"

Distributor of Sturdi Wall and Sturdi Wall Plus Brackets

Manufacturer of Quality Laminated Columns and Richland Perma-Columns

3-Ply, 4-Ply, 2+6, 2+8
100% Treated or Non Treated

Superior Treatment • #1SYP Lumber

• 30% Stronger than 6x6 solid

8252 Greenwich, Ohio 44837

Call Today for Nearest Distributor, Wholesale Only

Phone: 419-895-0036 FAX: 419-895-0062

Thank you for another successful year!



Circle Reader Service #440

FABRAL Booth 118 / Circle 137

Soon to celebrate 50 years of service to the post-frame industry, Fabral is a leader in the metal wall and roof systems market with full technical support, and experienced sales and service that customers call "the best in the industry." High-performing profiles in gauges, substrates and finishes fit any design or budget, while in-house project engineering and complete system components help dealers and contractors get the job done right.

FASCO AMERICA Booth 320 / Circle 138

FASCO America is the North American distribution arm for the vast range of tools and fasteners manufactured by The BECK Fastener Group, which has more than 100 years of experience providing products of consistent quality and innovation. Featured items include the 2016 PTIA award-winning cord free F70G Fence 40-315 fence stapler, Jumbo



Nails and two F91 Jumbo Nailers for big timber projects, plus the RoofLoc Metal Roofing System, including F58 RoofLoc tools and SteelThread SCRAIL fasteners.

FASTENERS DIRECT LLC

Booth 736 / Circle 139

Fasteners Direct LLC is a manufacturer of screws and a distributor of accessories for metal companies. The company's manufactured parts are distinguished for their unequalled resistance to corrosion, for the anti-back-out feature of the Sureloc metal-to-wood screw, and for the new Torpedo point on metal-to-metal screws. The Torpedo point delivers the fastest installation rate for self-drilling screws in the industry. Fasteners Direct is also the national distributor for Condenstop condensation control coils.

FILC USA/DRIPSTOP

Booth 212 / Circle 140

Dripstop from Filc USA helps fight condensation without insulation. Dripstop has specially-designed air pockets that store condensation and hold it until conditions change and it evaporates back into humidity. Because it arrives at the

job site already on the steel, there are no costs for installing insulation, plus it saves time by removing one step of the building process and helps fight corrosion by adding another layer of protection from the corrosive elements found in livestock confinement.

FRAME BUILDING NEWS / RURAL BUILDER

Booth 453 / Circle 141

Stop by the booth and visit with the sale and editorial staff of *Frame Building News* (the official publication of the NFBA) and *Rural Builder*: your year-round resources for information on post frame.

FREE STATE LUMBER CO.

Booth 735 / Circle 142

Since 1973 Free State Lumber has always let its customer's needs be the first priority. Filling orders for customers and supplying them with quality products in a timely manner is what makes them successful. Free State has many years of experience supplying a variety of materials to distribution facilities, retailers, post-frame, agricultural and shed builders. It has one of the largest inventories in the Eastern U.S. and

Dreams become **reality** using
GLUE-LAMINATED WOOD PRODUCTS.



New to Rigidply?

Stop by our booth at the Frame Building Expo. View samples of our Glu-Lam Posts, Beams, and other Heavy Timbers, and talk with industry experts.

717.866.6581

www.rigidply.com

701 E. Linden Street, Richland PA 17087



expo exhibitors

BY RURAL BUILDER STAFF

offers CCA and MCA treating; custom millwork (a variety of tongue and groove patterns) on 2- and 3-foot lumber; precision end trimming; custom re-sawing; dadoed 4x6 runners for buildings; from 1x4 boards to 12x12 timbers; plus a large variety of treated panels.

GARWOOD MFG. CO./SHEAR-X

Booth 531 / Circle 143

Shear-X brackets from Garwood Manufacturing provide superior building strength against seismic and lateral wind loads.

This new building technology allows the use of Garwood's continuous ridge venting system in blocked or unblocked diaphragms.

The system works on all types of roofs from "S" tile to flat asphalt shingle. Shear-X brackets are designed to transfer shear forces in roof diaphragms across the ridgeline and take the place of the connection between the roof sheathing and the continuous ridge board or ridge beam.



GRABER POST BUILDINGS INC.

Booth 525 / Circle 145

Graber Post has everything for a post-frame structure or metal roofing project. GPB manufactures metal panels for any residential, commercial, industrial, agricultural or roofing application. Graber Post also produces custom trusses, metal trims, laminated poles and now also features a steel coil division. GPB saves time and money by supplying all needed materials with just one phone call. Wholesale customers/distributors are desired.

H & H METAL PRODUCTS INC.

Booth 637 / Circle 146

H&H manufactures and distributes quality steel roofing and siding products and accessories for the post-frame building and residential roofing markets, including CondenStop. CondenStop is a highly absorbent, layered fleece material containing millions of micro spheres that absorb and contain condensed water. It prevents dripping inside the building until the water evaporates.

HERSHEY'S METAL MEISTER LLC

Booth 641 / Circle 147

Hershey's Metal Meister presents the Variobend USA folding machine: a unique hybrid of European and American design and manufacturing that gives you the advantages of both. Assembled from the ground up with an ever-increasing percentage of components made in Central Illinois eliminates waiting for foreign parts and service. A unique 280L work envelope,



HERSHEY'S METAL MEISTER LLC

#221
FRAME BUILDING
EXPO
10 YEARS 2017

NOVA FLEX

SILICONE

When You Want The Seal to Last

**FOR A SEAL THAT LASTS AS
LONG AS THE ROOF**



www.novagard.com

Circle Reader Service #290



HÖRMANN LLC



expo exhibitors

BY RURAL BUILDER STAFF

H-PAC PLASTICS LLC



extremely heavy-duty construction and lightning-fast servo-drive technology clearly makes the Variobend an unrivaled leader in productivity.

HÖRMANN LLC
Booth 342 / Circle 148

As one of the world's leading manufacturers of doors, Hörmann is committed to providing a wide selection of German-engineered and American-made products. This includes the Orion 3200 insulated sandwich door, the Phoenix 5200 carriage house style insulated sandwich door and the Tucana 5250 recessed panel insulated sandwich door, along with the SilentDrive 7500 garage door opener. These doors come standard with FingerGuard pinch-

resistant section joints for safety, 3-layer sandwich construction with polystyrene core and in-between section seals for increased energy efficiency.

H-PAC PLASTICS LLC
Booth 125 / Circle 149

H-Pac Plastics' EZ Liner and Hat Panel wall and ceiling panels are an ideal fit for agriculture applications. Products are stocked in various locations throughout the U.S. EZ Liner panels are available in 12-, 16- and 18-inch widths and are readily available to ship within 2-5 days. H-Pac's All-Weather Interlocking System allows panel contraction and expansion for an always-seamless appearance.



Western congratulates the NFBA on their 50th Frame Building Expo!



WALK DOORS



WINDOWS



#11 SLOTTED TRACK
THE MOST VERSATILE ROUND TRACK
PROUDLY MADE IN NEW CASTLE, IN

CALL US WITH YOUR REQUIREMENTS TODAY.
WE'LL HELP YOU BUILD THE FUTURE.

(800) 553-5142 www.westernproductsinc.com



CUPOLAS



DUTCH DOORS



MADE IN THE USA

expo exhibitors

BY RURAL BUILDER STAFF

I-BEAM SLIDING DOORS

Booth 119 / Circle 150

I-Beam Sliding Doors is a company founded on building heavy-duty, lightweight sliding doors for the post-frame industry. The company prides itself in supplying doors to fit your needs. "Doors That Work!" is its promise. Doors are now available with the 6000# Ultra Glide track and trolley system.

INNOVATIVE ENERGY

Booth 138 / Circle 151

For more than two decades, Innovative Energy has been a leader in delivering reflective insulation materials to the growing market of energy-conservation industries. Innovative Energy offers an extensive array of reflective insulation solutions to meet your requirements with a wide range of

applications, including metal building insulation, residential insulation, RV insulation and packaging insulation, all available in standard and custom sizes.



ISAIAH INDUSTRIES

Booth 708 / Circle 152

Isaiah Industries is a leading manufacturer of specialty metal roofing and a distributor of premium underlayments and ice and water shields. Through superior customer service, marketing support and the industry's fastest lead times, Isaiah Industries serves manufacturers and contractors with beautiful metal shingles that emulate traditional shakes, shingles, slate, and tile and its RoofAquaGuard underlayments.



JANUS INTERNATIONAL

Booth 506 / Circle 153

Janus International is the leading manufacturer of roll-up doors for the commercial and self-storage markets. Headquartered in Temple, Georgia, Janus has five domestic locations and two international facilities. Ease of use, quick delivery, unparalleled warranty and strong customer support has made Janus a favorite with door dealers nationwide since 2002.

K&K INDUSTRIES INC.

Booth 115 / Circle 154

K&K Industries, Inc. started 45 years ago in 1972. The business started with three employees, a small plant and one delivery truck. Currently, K&K Industries employs about 100 persons and has 12 delivery trucks. The company not only manufactures custom roof trusses, but also makes customized wood floor trusses and wall panels. Laminated beams, I-joist and Smartsiding (primed and prefinished) have also become a large part of its product line.



BeckryTex

NEW TEXTURED PAINT SYSTEM



Architectural low gloss anti-reflective coating

BeckryTex technology allows you to design unique and distinctive exterior textured finishes. A flexible, low gloss polyurethane coating, it is most often used on roofing for a well defined wrinkled look that creates the appearance of materials other than metal. A wide range of popular colors are available in this weather resistant product.

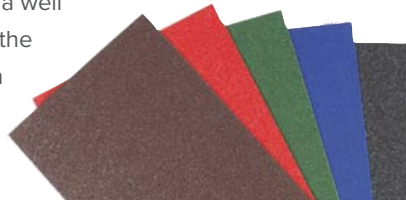

Beyond The Surface



Becker Specialty Corporation

2526 Delta Lane,
Elk Grove, IL 60007
info-beckerspecialty@beckers-group.com
P: (847) 766-3555
www.beckers-group.com

Circle Reader Service #338

KENWOOD PAINTED METALS

Booth 339 / Circle 155

Kenwood is a single-source supplier for pre-painted metal for the construction and door industries with more than 30 years experience in the coil-coating industry. It is a value-added supplier of pre-painted steel that will manage your supply chain with stocking locations throughout the United States.

KLAUER MANUFACTURING CO.

Booth 144 / Circle 156

From roofing, rainware and siding to metal building components, Klauer Manufacturing Co. is proud to offer products that are of the highest quality available and distributed throughout the U.S. It has been a trusted leader in the sheet metal building products industry since 1870.

KLOECKNER METALS

Booth 717 / Circle 157

Kloeckner offers painted and bare coils for roll forming of building panels and components. Distribution is available throughout the U.S. Kloeckner, offering more than 160 colors, provides paint systems in multiple grades, widths and substrates from Valspar, AkzoNobel and Dura Coat. Bare and acrylic-coated products, along with cold-rolled, stainless and aluminum coil are stocked across the country. Kloeckner also distributes plate, beams, structurals, pipe and tubing. The company is headquartered in Roswell, Georgia, and consists of three business segments: the Flat Rolled Group, Heavy Carbon Group and the Special Products Group which consists of building products.

KP BUILDING PRODUCTS

Booth 219 / Circle 158

KP Building Products is one of the largest manufacturers of PVC building products in North America. Made in the USA, the I-Span PVC wall and ceiling panel utilizes advanced PVC extrusion technology, is 100 percent virgin PVC and is ideal for post-and-frame applications. This panel is ½-inch thick, with a ribbed design that allows the panel to be installed directly on the framing up to a span of 24 inches.

LAKESIDE
CONSTRUCTION
FASTENERS



HEX HEADS
LIFE-TIME
WARRANTY.

LAKESIDE CONSTRUCTION FASTENERS

Booth 412 / Circle 159

Lakeside Construction Fasteners, a manufacturing and distribution company, offers multiple

fastener-foam solutions for the metal building industry. The T17 Wood-X #10 x 1 inch to 4 inches is designed for decking substrate materials. The new ZMax high-low threads and pierce point allows the fastener to quickly penetrate the metal panel, and the head is guaranteed not to red rust for the life of the metal panel. Venting foam solutions include the SC110Vent, SV3 and

SV2 Profile venting closure, ProGuard Seal and the new Ridge-X Vent. Over 100 sku's are in stock on roof boot flashings and many sealant products, including NovaFlex and Butyl Tape.

LELAND INDUSTRIES

Booth 501 / Circle 160

Leland boasts the fastener industry's first

PEEL IT. SEAL IT. DONE!

Peel & Seal® is the original self-adhering waterproofing membrane designed for low slope roofing or flashing applications. This single-ply membrane applies directly to the roof deck and serves as the final roofing surface. Ideal for hundreds of applications including whole roofs, dormers, sunrooms, metal roofs, and flashing around exterior penetrations.

BUILDING PRODUCTS CORP.

800-882-7663 | www.mfmbp.com

- Ideal for difficult roofing applications
- Aggressively adheres to the roof deck
- Self-seals around fasteners
- Aluminized surface limits solar gain
- Easy handling and installation
- Requires no coatings or coverings for permanent exposure to sunlight
- Virtually maintenance-free
- Variety of widths and color options
- 10-year limited warranty
- Made in the USA

Circle Reader Service #412

expo exhibitors

BY RURAL BUILDER STAFF

"long-life" powder coating warranty to match WeatherX, Spectracote and Perspectracote paint systems. Leland manufactures a complete line of fasteners for metal roofing, wood-frame or steel-frame projects, offering self-drilling and self-tapping fasteners in lengths to 4 inches in #10-12 and 14 diameters. Lengths up to 8 inches are also available. Leland fasteners are made of carbon

or stainless steel, plated, and coated or powder coated to match panel colors. Leland's powder coating covers both the head as well as under the head where corrosion starts.

LESTER BUILDING SYSTEMS LLC Booth 236 / Circle 161

Lester Building Systems is a leading post-frame

company with more than 150,000 buildings constructed since 1947. In support of its engineered building systems, Lester offers a lifetime structural warranty unmatched by others. Lester Buildings' dealers are empowered with Improv, an exclusive software that promptly designs, engineers, prices and draws buildings.

MB™ New Micro-Bit™ Engineering Stronger, More Consistent, Drill Point



The #1 complaint regarding sharp point screws is that they often drill slowly or not at all. ST Fastening Systems has married its metal building fastener technology into its new KWIKSEAL® MB™ with micro-bit engineering. This KWIKSEAL® MB™ will eliminate the slow drill or no drill complaint. The transition thread will still generate superior holding strength in all wood substrates. The point will generate small metal shavings & eliminate the long "pigtail" prevalent with sharp point screws. It all adds up to a cleaner, more consistent application.



Easy Multi-Layer Penetration

The MICRO-BIT will penetrate multiple thicknesses of metal panel often found at ridge cap applications more consistently than sharp point screws.



Eliminates Slow or No Drill



No Pig Tails

Call Today 800-352-4864



www.stfasteningsystems.com



LEVI'S BUILDING COMPONENTS

LEVI'S BUILDING COMPONENTS Booth 619 / Circle 162

The Snow Defender series is your quality choice for 'Made in the USA' snow retention, with more than 40 quick-ship color choices in four styles: 4500 and 1500 for exposed fastener panels, 6500 for standing seam roofing, and 55RF for vertical seam profiles using S-5! Clamps—all with 15-year warranties. Contact Levi's Building Components for quick service and expert advice. Levi's handy snow guard calculator is available online.



LIBERTY STEEL PRODUCTS INC. Booth 601 / Circle 163

Andrew and James Weller founded Liberty Steel Products in January 1965. Today, the business operates two ISO 9001:2008 certified steel servicing and processing plants in Northeast Ohio. Headquartered in North Jackson, Ohio, Liberty Steel Products processes all types of flat-rolled carbon steel. Its innovative handling, staging and delivery systems are designed to enable its customers to meet the rigorous demands of the 21st Century operation. Liberty Steel Inc. also offers a complete lineup of pre-painted products to the metal building industry. Now in its fifth year of stocking pre-painted coils, its customer base is growing rapidly. LSP Inc. has established relationships with coating lines, paint companies and mills throughout the world, allowing it to offer the same just-in-time services to both new and existing customers requiring a pre-painted product at a competitive price.

MAC METAL Booth 312 / Circle 164

MAC Metal is pleased to offer complete

Circle Reader Service #429



MAC METAL

package post-frame buildings to customers in its service area. Features include engineered trusses, 8x8-inch treated posts and many more options to choose from.

MARCO INDUSTRIES

Booth 437 / Circle 165

The Marco Weather-Tite System consists of innovative roof ventilation products and quality accessories for the metal roofing industry. For more than two decades, Marco products and services have focused on providing customers "Value Through the Roof". From the award-winning LP2 Ridge Vent to Flex-O-Vent rolls, durable closure materials, superior metal roof sealant, underlayment products, pipe flashings, clips, fasteners and outstanding warranties and service, Marco can be counted on for convenient solutions, industry expertise and outstanding service throughout North America.



MARION MANUFACTURING INC.

Booth 733 / Circle 166

Marion Manufacturing Inc. offers a wide variety of roll-forming equipment, automation systems and machined parts. Products and services available include panel roll-form machines, uncoilers, coil cars, up enders, shears, slitters, trim roll-form machines, stackers, hemming machines and more.

MARTIN BUILDING PRODUCTS

Booth 127 / Circle 167

Martin Building Products has been in the reflective insulation business for 13 years. It has represented multiple manufacturers and listened to customers' feedback, both positive and negative. As a result they are rolling out VerSola, a new brand of reflective insulation produced in the USA at Martin's Midwest facility. Industry experts were consulted to ensure that Martin Building Products would be adding the highest levels of preventative additives to safeguard against deterioration

and degradation of the products. The Martin facility also boasts a dedicated start-of-the-art machine to produce both 4- and 6-foot seamless rolls. Extensive testing by the industry's premier third-party laboratory has been completed and results have surpassed all industry standards.

MAZE NAILS CO.

Booth 100 / Circle 168

Maze Nails is the exclusive manufacturer of Stormguard double hot-dipped galvanized nails with a lifetime warranty against rust. In business since 1848, Maze offers a full line of specialty nails in bulk for hand driving

Do You Need A STRONGER CONNECTION?

Our **PANEL-TITE® ULTRA 14** provides almost 2x more strength than standard metal-to-wood screws.

- #14-10 diameter for superior pull-out strength
- Type 17 milled point eliminates splitting of wood
- TRI-SEAL® coated for use in treated lumber
- Available in lengths up to 3-1/2"







TRIANGLE FASTENER CORPORATION

www.trianglefastener.com

800.486.1832



Circle Reader Service #425

expo exhibitors

BY RURAL BUILDER STAFF

and in collated sticks and coils for popular pneumatic nailers. Maze has been serving the post-frame industry for many years, providing painted rubber washer nails for corrugated roofing and siding. Maze post-frame nails meet ASTM F 1667 specification. In addition, Maze manufactures nails for fiber cement siding products, cedar and redwood sidings, fencing, decking and roofing. Customers have come to identify Maze Nails with top-quality products, excellent customer service and quick, dependable shipments. Help hammer out foreign competition one nail at a time and bring jobs back to America. All Maze Nails are proudly 100 percent made in the USA.



When you need steel,
you can count on us.

As the leading distributor of high quality flat rolled steel coils, you can count on United Steel Supply to offer competitive pricing, on-time delivery and superior customer service.

We furnish Galvalume®, galvanized, and prepainted coils for all metal roofing and siding applications. With a wide variety of stock colors and color-matching capabilities, you're sure to find what you need with United Steel Supply.



For more information, visit www.unitedsteelsupply.com or call 512-263-0954.

Circle Reader Service #564

MCELROY METAL Booth 309 / Circle 169

McElroy Metal's warm-forming and edge-coating processes on Max-Rib and Mesa metal wall and roofing panels improves field performance for post-frame buildings. Warm-forming prevents micro-fracturing of the substrate and silicone modified polyester-paint coating, and blocks moisture from coming in contact with the raw steel and creating rust. Edge-coating is a factory process where a clear-coat rust inhibitor is applied to the cut-edge of panels, reducing the risk of cut-edge corrosion. Designed for post-frame and



residential applications, the Mesa panel is a patent- and copyright-protected panel with a nearly invisible lap. The Mesa panel adds beauty to any project, measuring 36 inches wide with ribs 3/4-inch high. McElroy Metal, a leading supplier of metal wall and roofing products to the post-frame industry, is an active supporter of the National Frame Building Association. McElroy Metal is also a 34-time winner of the *Rural Builder* Gold Key of Excellence, as selected by readers.

MENARDS

Booth 201 / Circle 170

Menards began as a seller and builder of pole barns. Today it is the largest manufacturer and supplier of post-frame materials and services. The broadest selection of trusses, unparalleled steel panels and numerous trim shapes are in stock as well as custom trim made to your specs, laminated columns and much more. Complete design, engineering, technical drawings, presentation drawings and estimating services are available.

METAL ROLLFORMING SYSTEMS

Booth 218 / Circle 171

Metal Rollforming Systems designs and manufactures industry-leading rollforming equipment and accessories. Its complete in-house design and manufacturing facility allows it to price equipment at a very competitive price, making it a leader in rollforming equipment manufacturing. MRS' product lines consist of single- and double-



METAL ROLLFORMING SYSTEMS



MID-COLUMBIA LUMBER

deck rollformers, single- and multi-trim rollformers, slitters, sheet stackers and much more. MRS takes great pride in customer support before and after the sale.

METAL ROOFING ALLIANCE

Booth 713 / Circle 172

The Metal Roofing Alliance was formed in 1998 by a small group of forward-thinking metal roofing manufacturers with the main goal of educating consumers about the many benefits of metal roofing. Over the years, its membership has grown to include paint companies, material suppliers, industry publications and more.

METALFORMING, INC.

Booth 143 / Circle 173

Headquartered in Peachtree City, Georgia, and privately held, MFI is the largest supplier of high-end architectural sheet metal machines in North America. It is also a world leader in providing software, communications, training and consulting services for companies in the metal building and roofing industries, helping its customers to optimize both job site and factory operations in ways that reduce waste, increase revenue and efficiently position them to meet the "just-in-time" needs of today's construction business.

METAL SALES MANUFACTURING CORP.

Booth 715 / Circle 174

Metal Sales offers a complete line of metal roof, wall and fascia panel systems for the agricultural, residential and commercial markets. Celebrating its 54th year in 2017, Metal Sales has the expertise to service post-frame builders and its customers' needs in new construction, expansion and retrofit.

METRO ROOF PRODUCTS

Booth 730 / Circle 175

Metro's lightweight (1.5 pounds per square feet) stone-coated steel roof systems come in five profiles, providing the right look for any architectural style. MetroShingle delivers the look of asphalt laminates, while MetroRoman, MetroTile and MetroShake create a traditional clay tile or hand-split wood shake impression without the weight and fire danger, and MetroCottage Shingle with its multi-color shading suits any home. All Metro products are backed by a 50-year limited warranty covering 120-mph winds, Class-4 hail resistance and a 25-year limited appearance warranty.

MID-COLUMBIA LUMBER

Booth 142 / Circle 176

Mid-Columbia Lumber's Engineered products

The building suppliers you can trust focus on
BUILDING STRONG RELATIONSHIPS.

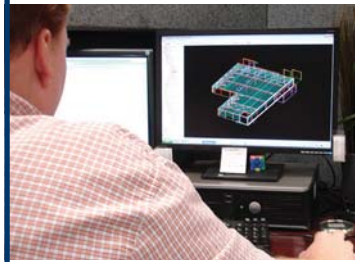

The most solid foundation upon which to build a partnership is trust. That's why, for more than 60 years, Varco Pruden has focused on creating relationships that last. Our interest is always your best interest. While we offer decades of experience and expertise, we also offer advanced engineering and energy efficient proprietary products and systems. Through evolving technology, VP Builders have advantages in the field with enhanced electronic drawings and apps for managing and tracking deliverables.. You can depend on us to work for you. Because we're not just reliable, we're dedicated. And we never compete against our builder partners.

We offer superior products and service, including:

- ◆ Unrivaled quality
- ◆ Cutting-edge technology and innovation
- ◆ Unequaled marketing tools and resources
- ◆ A wide array of products
- ◆ Experienced project management and field support

Contact Varco Pruden today. Let us show you how, together, we can add value to your business and your reputation.



Visit www.VP.com/ad/RBGK to receive this free brochure "Built on a Tradition of Excellence."

Circle Reader Service #301

When **Quality** Matters
**SELECT THE
 BEST**

SNOW RETENTION SYSTEMS



**Snow
 DEFENDER™**
4500

METAL TO WOOD FASTENERS



Fastgrip™



Safe. Secure. Sealed.

METAL ROOFING ACCESSORIES

**FloVent™
 R120**

NEW!



on over **1,600** Metal Roofing
 Accessories and Fasteners

LEVI'S™
 BUILDING COMPONENTS

**Booth
 #619**

Call for a **FREE** Catalog!
(877) 897-7020

www.levisbuildingcomponents.com

Circle Reader Service #392

expo exhibitors

BY RURAL BUILDER STAFF

provide the end user with longer lengths (up to 60 feet), kiln-dried material, superior straightness, stability and consistent performance for demanding applications. Typical sizes range from 2x4 through 2x12. Uses range from industrial framing, pole barns to include joists, tall walls and trusses, concrete forms, beams, plates, posts, decking etc. All products are WWPA certified and meet all building codes and standards.

MILL STEEL CO.
Booth 507 / Circle 177

Now in its 57th year of business, Mill Steel is more dedicated than ever to its history of innovation and people-first culture that has made it one of the largest flat-rolled steel service centers in North America. The company is comprised of 28 production lines across five locations: Grand Rapids, Michigan; Detroit, Michigan; Birmingham, Alabama; Jeffersonville, Indiana; and Anderson, Indiana. This allows for quick turnarounds of pre-painted or bare steel for customized color match. Mill Steel proudly offers AkzoNobel, PPG and Valspar color systems.

MITEX INTERNATIONAL INC.
Booth 126 Circle 238

A Texas-based manufacturing, distribution and marketing company of insulation and sealing products, Mitex International provides local solutions to wholesalers and distributors in residential, metal and post-frame markets. With multiple warehouses, trained sales representatives and global thinking, Mitex's brand Mitee insulation and Mitee sealing products are known for their quality, availability and competitive edge.

MSW PLASTICS, INC.
Booth 705 / Circle 178

MSW Plastics Inc. is a leading profile extrusion company based in Palmerston, Ontario, Canada. It strives to produce high-quality products that provide PVC liner panel and partition solutions to its customers. MSW believes that quality and customer service are the first priorities. Products that the company manufactures include Trusscore, Ribcore and Norlock. It also offers custom extrusion. It has distribution partners across North America and also ships product to many countries around the world.

MWI COMPONENTS
Booth 319 / Circle 179

MWI Components is a leading manufacturer and supplier of products for the post-frame industry. MWI Components offers more color options than anyone in the industry. With more than 100 colors available in steel, almost 40 colors in aluminum and 50-plus powder coat colors, the combinations are endless. New in 2016, MWI now offers a line of affordable vinyl



windows. The 4400 series super rail is designed to be the most heavy-duty aluminum rail option available in the post-frame industry.

**NATIONAL FRAME BUILDING
 ASSOCIATION**

Booth 349 / Circle 180

The NFBA is the only national trade association that represents post-frame industry professionals. The association is the country's primary source of post-frame building resources, research, networking, news and education. Stop by the booth to learn more.

NATIONAL HARDWARE

Booth 720 / Circle 181

National Manufacturing Co. was started in 1901 as a small wagon company in Sterling, Illinois. The focus soon turned to manufacturing and selling builder's hardware. Over the course of the next century, National Hardware grew to be one of the leaders in builders' hardware. Today, the National Hardware brand has reached global status and offers more than 8,500 products. Its focus is on providing the best hardware and service to its valued customers.

NEW PROCESS STEEL LP

Booth 238 / Circle 182

This Indiana-based multi-divisional steel service center specializes in flat-rolled carbon products, including all materials needed in the frame-building industry for panels and roofing. New Process has coil in galvanized, Galvalume and pre-painted materials. Several paint systems are available as well as custom painting through regional roll coaters.

NOFP INC.

Booth 338 / Circle 183

NOFP manufactures high-performance reflective-foil insulation and under-concrete insulation for commercial, agricultural and residential construction. The BarrierX5 under-concrete insulation is 1-1/4 inches thick and comes in a 4x60 foot roll of flexible EPS foam used for radiant-heated floors and goes

directly on the grade. It meets the R-5 insulation requirement for most radiant-floor installations. It's a great replacement for rigid-sheet insulation because it is flexible and won't break when walked on. In addition, it has poly film layers laminated to the top and bottom so it doubles as a vapor retarder.

NORTH STAR METALS MFG. CO.
Booth 707 / Circle 184

Established in 1994, North Star manufactures metal roofing, siding, custom components and assemblies for agricultural, architectural, industrial and residential markets. North Star utilizes state-of-the-art roll-forming and folding equipment to produce consistently top-quality panels and trims exactly to order. A large selection of roll-formed panel and trim is available and CNC folding capabilities allow North Star to satisfy any custom-panel or trim requirements, including matching discontinued and hard-to-find panels. North Star also offers on-site delivery with moffett-equipped tractor-trailer unit and roll-off-capable gooseneck trailers.

NOVAGARD SOLUTIONS
Booth 221 / Circle 185

Novaflex metal roof sealant is one of the premier silicone sealants available, with excellent adhesion to all metal types including Kynar, and permanent flexibility. Novaflex extrudes down to -20° F and up to 120° F, and is tack free in 10-15 minutes. The seal stays flexible for years with minimal shrinkage, so there is no sagging, slumping or cracking.



OHIO TIMBERLAND PRODUCTS INC.
Booth 407 / Circle 186

Ohio Timberland Products has long been considered the pioneering leader of nail-laminated column manufacturing and supply. While a number of suppliers have emerged over the years copying its design, Ohio Timberland remains true to the engineering principals involved with column production. Ohio Timberland's Christ-centered mission remains the same—to provide the post-frame community with the best quality nail-laminated columns delivered in a timely and economical fashion.

ONDULINE NORTH AMERICA INC.
Booth 131 / Circle 187

Onduline North America manufactures Tuflex building panels. Poly-Lite skylight/sidelight panels bring natural light into buildings. The Poly-Lite comes in 9- and 12-inch profiles, 38 inches wide, in smoke, clear or white. Tuflex PVC ag-liner panels, for lining the walls and ceilings of agricultural structures, come in corrugated 9-inch profiles, 38 inches wide, in black or white.

**OSI ADHESIVES & SEALANTS/
HENKEL CORP.** Booth 549 / Circle 188

OSI Quad Max is a 3-in-1 window, door and siding sealant that evolved from job site necessity and is formulated for the most demanding conditions. It can be applied in wet conditions and offers consistent, easy extrusion in both hot or cold conditions. It has superior flexibility with 5X stretch and superior bonding capabilities on all primary materials. Quad Max is perfectly color matched and recommended by leading building material manufacturers.

**PAINT VALLEY PARTS LTD./
ACU-FORM** Booth 712 / Circle 189

Acu-Form, a division of Paint Valley Parts, is a manufacturer of metal forming equipment such as



ag panel, stretch wrapper, corner, post-cut shear, hemmer, slitter, J-channel, rat guard, uncoiler, table and roll, ridge cap and more for commercial and residential construction use. The company's goal is to meet and exceed customer expectations. The No. 1 priority is to send customers a durable, top-performing machine that will give years of trouble-free service. Acu-Form uses D2 tool steel as a standard.



PALRAM AMERICAS
Booth 631 / Circle 190

Palram Americas, a leading manufacturer of PVC and polycarbonate panels, created the MetalMatch technology, allowing for the use of SunSky polycarbonate panels for daylighting options with virtually any metal profile available. Palram also offers AG-TUF, a PVC liner panel for use in agricultural buildings. The all-new DuraClad PVC multi-wall liner panel will be introduced at the show.



**BECAUSE WHAT'S BEHIND
THE DOOR MATTERS**

With a design that meets agricultural and post-frame needs, the people and components behind DBCI doors make them the most durable and reliable in the industry.

Manufactured using the highest quality materials, DBCI doors are assembled with the integrity required to protect our customers' assets and maximize efficient operations.

Visit us at NFBA | March 8-10, Nashville | Booth #727

800.542.0501 | www.dbci.com

expo exhibitors

BY RURAL BUILDER STAFF

PARAMOUNT METALS

Booth 724 / Circle 191

Paramount Metals provides 29- and 26-gauge Grade D and E coils to metal building manufacturers in the U.S. and Canada. Paramount's goal is to provide service and guidance to help businesses grow. Paramount stocks a full line of coil inventory including 20-inch standing seam coils. Paramount is better able to control delivery by using its own trucks and has the ability to provide several common trims and trim flat sheets.

PERMA-COLUMN INC.

Booth 413 / Circle 192

Perma-Columns are 5-foot precast concrete columns that keep wood out of the ground, ensuring your building's foundation will never rot. They are the first product to combine the economy of post-frame construction with the durability of a concrete foundation.

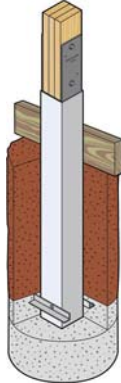

PERMANENT BUILDING SOLUTIONS

Booth 732 / Circle 193

PLANET SAVER INDUSTRIES LLC

Booth 443 / Circle 194

GreenPost from Planet Saver Industries offers a unique non-toxic concept for protecting in-ground wood from the harmful effects of ground-contact decay, at the same time providing uplift restraint. GreenPost is laboratory proven, termite tested and building-code compliant and is applied to posts using a specialized production machine so posts arrive ready for installation. GreenPost also complements pressure-treated posts by providing an environmentally-friendly barrier, helping to keep the preservatives in the post longer.



PLASTI-SLEEVE/ HOMEWORK INC.

Booth 211 / Circle 195

With 20 years in production, the original

Plasti-Sleeve is a leader in post protection for buildings, offering economical, versatile and easy slide-on installation for 20 different post sizes. Made in the USA from the highest-quality black HDPE plastic, Plasti-Sleeve offers unparalleled in-ground durability. Also available is Plasti-Skirt, an economical, easy-to-use, plastic skirt-board protector available for 2x8 and 2x6 skirt boards.

PLYCO CORPORATION

Booth 201 / Circle 196

Plyco manufactures the most durable and dependable building components for the post-frame, metal building, commercial and light-commercial industries. Strength means long-lasting toughness, quality, performance and aesthetics for contractors and building owners. Plyco's full line of walk doors and windows are engineered to meet today's building codes. From commercial to agricultural to outbuildings Plyco manufactures quality products to fit your construction needs. Contractors across North America trust Plyco's full line of track, SDR, ridge vents, cupolas, slide doors, Dutch doors, Champion doors, Equus products and Ply-Foil. One company



INTRODUCING OUR NEWEST SOLUTION TO KEEPING SNOW IN ITS PLACE THIS WINTER SEASON.

DUALGARD™

INNOVATIVE DUALGARD BRACKET:

Offers added flexibility

DUALCLIP SNOW AND ICE SYSTEM:

Secured between pipes and deck to further block snow and ice

S-5! MINI-CLAMP ASSURANCE:

Laboratory tested and certified by a third party authority

A complete, affordable system only S-5! can provide. DualGard also works with most face-attached roofs and VersaGard™. Visit us online to use our DualGard Calculator. Product now available to S-5! Distributors.

A2LA Cert No. 0018.04

Always choose the best solution. Always choose S-5!

Contact your S-5! distributor to learn more about DualGard

www.S-5.com | 888.825.3432



Circle Reader Service #450

The faster screw.
The stronger nail.

SCRAIL®
The Faster Fastener®

BECK Fastener Group, FASCO America, SCRAIL and The Faster Fastener are registered trademarks of the BECK Fastener Group.

Booth #320

www.fascoamerica.com

Circle Reader Service #359



for durable and reliable building components makes Plyco the easy choice for contractors.

POST PROTECTOR INC.

Booth 421 / Circle 197

Post Protector is a slide-on barrier system, delivering serious post-decay protection. Post Protector tackles post longevity concerns by eliminating both soil/concrete-to-post contact and chemical migration. Post Protector retains the simplicity, affordability, speed and strength of typical post-in-ground construction

techniques. Horizontal perimeter ribs, in conjunction with provided hardware, yield substantial post uplift protection and best of all, installation is a snap. It's simple: by keeping soil out and treatment in, Post Protector dramatically improves post-frame foundations.

POST FRAME MANAGER

Booth 132 / Circle 198

PostFrame Manager is a most powerful takeoff and estimating system created for the post-frame construction industry. With the ability to estimate buildings with up to four wings, interior walls, multiple roof styles, architectural features like eyebrows, wraparounds and more, PostFrame Manager will enable the user to take its customers on a 3D tour of their dream building, produce a customer quote, architectural drawings, bills of material and supplier purchase orders for post-frame and studwall buildings in under five minutes. Stop by for a quick demonstration on the trade show floor.

POWERLIFT HYDRAULIC DOORS

Booth 343 / Circle 199

PowerLift has built hydraulic doors continuously since 1992. It has 36 local support centers that



POWERLIFT HYDRAULIC DOORS

manufacture, deliver and install every single door. PowerLift strives to make your building project and your long-term ownership experience simple and hassle free.

PPG INDUSTRIES

Booth 215 / Circle 200

PPG metal coatings balance the performance and budget demands of building product manufacturers, building owners and architects. DuraStar Ultra-Cool coatings, featuring PPG's proprietary pigment dispersion technology, are silicone-modified polyesters that achieve near-premium levels of weatherability, durability and color and gloss retention. DuraForm polyester coatings deliver



MAIN STREET™
VINYL WINDOWS BY A.J.

Single Hung

Patented EZ-V™ Trim System —
The quick and easy way to trim your vinyl windows.

Features:

- White or custom color matched
- Leak-free flashing
- Fully trimmed, requires no application of a J-channel
- Resistant to thermal expansion and contraction
- Saves time and installation labor



Fixed Lite Picture

Horizontal Slider



Building Ideas

A.J. Manufacturing, Inc.
1217 Oak Street
Bloomer, WI 54724
800.328.9448 www.ajdoor.com



expo exhibitors

BY RURAL BUILDER STAFF



PPG INDUSTRIES

long-lasting, value-oriented protection and color for metal panels, roofs, doorframes and garage doors. DURANAR fluoropolymer coatings provide exceptional performance for high-end wall panels and roofing applications.

PRECOAT METALS

Booth 613 / Circle 201

You name it, Precoat Metals can process it. With 13 plants strategically placed, the ability to coat up to 72 inches wide and an extensive line of processing capabilities, Precoat Metals has positioned itself as an industry leader. From its outstanding customer

service, to its attention to detail, it has you covered. Precoat Metals is your one-stop shop for coil coating needs. Many of the company's innovative products will be on display.

PROGRESSIVE METALS

Booth 433 / Circle 202

Progressive Metals aims to meet and exceed all customer coil needs. Offering high-quality metal in many colors, excellent service and exceptional delivery will put Progressive Metals on the top of your list as the choice for all your metal roofing options.

RADIANT OUTFITTERS

Booth 723 / Circle 203

Radiant Outfitters specializes in hydronic radiant floor heat. Radiant floor is a popular option for post-frame builders. Radiant Outfitters takes the guesswork out of floor heat for building contractors. Radiant Outfitters offers very unique tubing that has 20 percent better heat transfer and the highest pressure and



temperature ratings on the market. Add floor heat to your offering and add to your profits.

RESOLITE, A DIVISION OF STABILIT AMERICA

Booth 548 / Circle 204

Since 1951, Resolite FRP Composites has been in the forefront of new product development in fiberglass reinforced plastic panels. Resolite designed the first fire-retardant fiberglass reinforced plastic sheet and introduced the first walkable FRP panel. Resolite is now offering a new line of Makrolon polycarbonate corrugated and multiwall panels. The corrugated panels were specifically designed for metal buildings as skylights and sidelights. These polycarbonate corrugated sheets match most of the metal panel profiles in the U.S. market.

RICHLAND LAMINATED COLUMNS

Booth 313 / Circle 205

Owner Elmer Sensing and the staff of Richland Laminated Columns would like to take this opportunity to thank the company's loyal customers for 12 years of growth. In that short time it has experienced three major expansions



Circle Reader Service #317

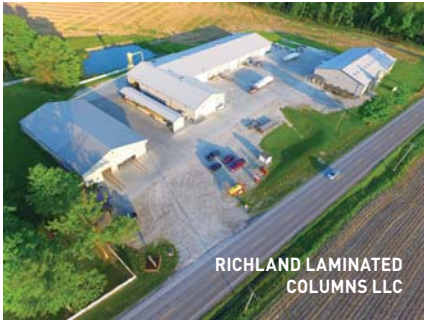

RICHLAND LAMINATED COLUMNS LLC

at its headquarters in Greenwich, Ohio. Richland Laminated continues to grow, and today manufactures quality laminated columns and Richland Perma-Columns and is a distributor of Sturdi Wall and Sturdi Wall Plus Brackets, Post Protectors, The Footing Pad and Concrete Post Pads. Elmer looks forward to meeting you at the Frame Building Expo.

RIDGE CRAFT LLC
Booth 706 / Circle 206

Royal Crowne Cupolas are manufactured by Ridge Craft, which features one of the most extensive



RIDGE CRAFT LLC

lines of cupolas in the industry, including a line specific for the post-frame industry. These cupolas range in size from 24 to 72 inches, in square and octagonal configurations and available with louvers or windows. These cupolas can be made to match most metal colors. Ridge Craft also has a large selection of vinyl, cedar and copper cupolas.

RIGIDPLY RAFTERS INC.
Booth 318 / Circle 207

Rigidply Rafters has improved the quality of post-frame buildings by manufacturing and distributing

the original 100 percent glue-laminated post. By specifying Rigidply Posts, you guarantee the labor-saving and quality advantages of true glulam posts. Not only are glulam posts lighter, straighter and stronger than solid-sawn posts, but they minimize cracking and splitting. When planning your next building project, Rigidply Rafters promises to supply integrity, quality and service with your glulam posts.

ROPER WHITNEY
Booth 436 / Circle 208

S-5! Booth 324 / Circle 209

S-5! zero-penetration clamps attach ancillary items to standing seam metal roofs without violating the integrity of the roof or the roof's warranties. The patented clamps mount snow-retention and wind-performance systems, solar arrays, signs/banners, light fixtures, gas piping, stack/flue bracing, walkways, HVAC, lightning protection, equipment screens, conduit, condensate lines and more.

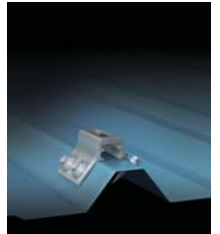

ASC MACHINE TOOLS, INC.

HIGH QUALITY ROLLFORMING EQUIPMENT AND MORE!











BOOTH # 607

WWW.ASCMT.COM

Circle Reader Service #361



Looking for more information from companies featured in this issue?

Use the Reader Service card facing this page to get **FREE** information from our advertisers!

Free online info at www.bit.ly/info-rbfn

ADVERTISERS

RS #	Company	Page #
334	A J Manufacturing, Inc.	38-39,55
291	AB Martin.....	75
524	AG-Co Inc.....	60
361	ASC Machine Tools, Inc.....	38-39,57
459	Akzonobel.....	5,38-39
317	Alpine Snowguards.....	56
321	Amerilux International LLC.....	66
	Atlas Bolt & Screw.....	38-39
441	Aztec Washer Co.....	60
338	Becker Specialty Corp.....	38-39,46
	Best Products.....	38-39
	Bradbury Group, The.....	38-39,73
	Bullington Lumber & Treating...38-39	
553	CHI Overhead Doors.....	61
386	Cannonball: HNP, LLC.....	7,38-39
	Central States Mfg.....	38-39
	Clark Industries.....	73
358	DBCI.....	53
	Daystar System, LLC.....	38-39
	Direct Metals, Inc.....	38-39
581	Dura Coat.....	9
316	Dynamic Fastener.....	11,38-39
407	Everlast Roofing, Inc.....	38-39,76
	Extrutech Plastics.....	73
393	Fabral.....	16,17
359	Fasco America.....	38-39,54
384	Filc USA, LLC.....	15

RS #	Company	Page #
464	Garwood Manufacturing Company.....	13,38-39
433	Grabber Post Buildings.....	35
536	Hershey's Metal Meister.....	21
512	I Beam Sliding Doors.....	62
	K+K Industries Inc.....	38-39
469	Lakeside Construction Fasteners.....	23,38-39
341	Leland Industries.....	36,38-39
392	Levi's Building Components.....	52
412	MFM Building Products Corp.....	47
308	MWI Components.....	2,38-39
	Mac Metal Sales Inc.....	38-39
	Marion Manufacturing.....	38-39,73
	Martin Building Products.....	38-39
306	Maze Nails Company.....	25
422	McElroy Metal, Inc.....	27,38-39
584	Metal Rollforming Systems.....	62
378	National Frame Building Assn.....	19,71
463	Nationwide Protective Coating Mfrs., Inc.....	37
533	New Process Steel Corporation.....	61
290	Novagard Solutions.....	38-39,44
	Old Country Cupolas.....	73
	PPG Industries.....	38-39
516	Paint Valley Parts, LTD.....	40
350	Palram Americas.....	38-39,41

RS #	Company	Page #
	Perma-Column, Inc.....	39
313	Plyco Corporation.....	29,38-39
	Power Lift Hydraulic Doors.....	38-39
399	Precoat Metals.....	38-39,63
503	Replications Unlimited.....	8
440	Richland Laminated Columns.....	38-39,42
426	Ridge Craft.....	64
382	Rigidply Rafters.....	43
450	S-5!.....	54
414	Schweiss Doors.....	64,73
429	ST Fastening Systems.....	38-39,48
454	Semmler Systems, Inc.....	65
482	Sno Gem, Inc.....	65
540	Spectrum Brands HHI.....	31
375	Starwood Rafters, Inc.....	73
411	Thermal Building Concepts...38-39,66	
	Tri-State Lumber Company.....	38-39
425	Triangle Fastener Corp.....	49
564	United Steel Supply.....	50
301	VP Buildings, Inc.....	51
	Valley Lumber.....	38-39
484	Valspar Corporation.....	33,38-39
374	Western Products of Indiana.....	45
511	Wick Buildings.....	4
	Worldwide Steel Buildings.....	38-39

STORY RESOURCES

RS #	Company	Page #
TOP PRODUCTS OF 2016		
240	Grabber Post Buildings.....	10
241	Eagle Metal Products.....	10
242	A.J. Manufacturing.....	10
243	Metal Sales Mfg.....	10
244	Sno Gem Inc.....	12

RS #	Company	Page #
245	MWI Components.....	12
246	Applicad-USA.....	14
247	SFS intec.....	14
248	Plyco Corporation.....	14
249	CannonBall:HNP.....	16
250	National Hardware.....	16

RS #	Company	Page #
251	I-Beam Sliding Doors.....	18
252	Wick Buildings.....	18
253	Replications Unlimited.....	18
254	MWI Components.....	18
255	PowerLift Hydraulic Doors.....	18
256	Palram Americas.....	18

STORY RESOURCES *continued*

RS #	Company	Page #	RS #	Company	Page #	RS #	Company	Page #
NEW PRODUCTS AT THE EXPO								
102	AG-CO	30	139	Fasteners Direct	43	188	OSI/Henkel Corp.	53
116	Bradbury	28	140	Filc USA/DripStop	43	189	Paint Valley Parts	53
136	Extrutech Plastics	28	141	Frame Building News	43	190	Palram Americas	53
159	Lakeside Fasteners	26	142	Free State Lumber Co	43	191	Paramount Metals	54
167	Martin Building Products	28	143	Garwood Mfg./Shear-X	44	192	Perma-Column	54
204	Resolite	30	144	Glick Metals	44	193	Permanent Bldg Solutions	54
210	Safe-Way Door	30	145	Grabber Post Buildings	44	194	Planet Saver Industries	54
217	Simpson Strong-Tie	28	146	H & H Metal Products	44	195	Plasti-Sleeve	54
EXPO EXHIBITORS								
100	3GM Steel Inc.	32	147	Hershey's Metal Meister	44	196	Plyco Corporation	54
101	A.B. Martin Supply	32	148	Hormann	45	197	Post Protector, Inc.	55
102	AG-CO Inc.	32	149	H-Pac Plastics LLC	45	198	PostFrame Manager	55
103	AGCOR	32	150	I-Beam Sliding Doors	46	199	PowerLift Hydraulic Doors	55
104	A J Manufacturing, Inc.	32	151	Innovative Energy	46	200	PPG Industries	55
105	Akzo Nobel Coatings	32	152	Isaiah Industries	46	201	Precoat Metals	56
106	Alpine Distribution	34	153	Janus International	46	202	Progressive Metals	56
107	Amarr/Entrematic	34	154	Janus International	46	203	Radiant Outfitters	56
108	Ameripak	34	154	K+K Industries	46	204	Resolite, Division of Stabilit	56
109	American Building Components	34	155	Kenwood Painted Metals	47	205	Richland Laminated Col.	56
110	ASC Machine Tools	34	156	Klauer Manufacturing	47	206	Ridge Craft	57
111	Atlas Bolt & Screw	34	157	Kloeckner Metals	47	207	Rigidply Rafters	57
112	Bay Insulation Systems	34	158	KP Building Products	47	208	Roper Whitney	57
113	Beckers Group	34	159	Lakeside Fasteners	47	209	S-5!	57
114	Best Products	35	160	Leland Industries	47	210	Safe-Way Garage Door	60
115	Bestline Bldg. Products	35	161	Lester Building Systems	48	211	Schweiss Doors	60
116	Boral	35	162	Levi's Bldg. Components	48	212	Scott Systems	60
117	Borkholder Buildings	35	163	Liberty Steel Products	48	213	Semmler Systems, Inc.	60
118	Bradbury Group, The	35	164	MAC Metal	48	214	SFS Intec, Inc.	61
119	Brut Post Grabber, The	36	165	Marco Industries	49	215	Silvercraft	61
120	Bullington Lumber	36	166	Marion Manufacturing	49	216	Silvermine Stone Co.	62
121	Burrow's Post Frame	37	167	Martin Building Products	49	217	Simpson Strong-Tie	62
122	Cannonball: HNP	37	168	Maze Nails Company	49	218	ST Fastening Systems	62
123	Capital Forest Products	37	169	McElroy Metal Inc.	50	219	Steel Dynamics	62
124	Central States Mfg.	37	170	Menards	50	220	Stiletto Tools	63
125	C.H.I. Overhead Doors	37	171	Metal Rollforming Systems	50	221	Swenson Shear	63
126	Cidan Machinery Inc.	40	172	Metal Roofing Alliance	51	222	Symun/Constr. Maestro	63
127	Combilift USA	40	173	Metalforming	51	223	Taylor Steel	63
128	Daystar System	40	174	Metal Sales Mfg.	51	224	Thermal Bldg Concepts	64
129	DBCI	40	175	Metro Roof Products	51	225	Timber Tech Engineering	64
130	Direct Metals	41	176	Mid-Columbia Lumber	51	226	Timber Technologies	64
131	Dura Coat Products	41	177	Mill Steel	52	227	Triangle Fastener Corp.	64
132	Dynamic Fastener	41	238	MiTex International	52	228	Tri-State Lumber Co.	64
133	East Coast Fasteners	41	178	MSW Canadian Plastics	52	229	Tru-Seam Metal Solutions	65
134	Energy Panel Structures	42	179	MWI Components	52	230	Trussmate	65
135	Everlast Roofing	42	180	NFBA	52	231	United Steel Supply	65
136	Extrutech Plastics	42	181	National Hardware	52	232	U.S. Steel Truss	65
137	Fabral	43	182	New Process Steel	52	233	Valley Lumber	66
138	Fasco America	43	183	NOFP	52	234	Valspar Corporation	66
			184	North Star Metals Mfg.	53	235	Weaver Metal Products	66
			185	Novagard Solutions	53	236	Western Products	66
			186	Ohio Timberland Products	53	237	Wick Buildings	66
			187	Onduline North America	53			

expo exhibitors

BY RURAL BUILDER STAFF



SAFE-WAY DOOR

SAFE-WAY DOOR

Booth 102 / Circle 210

Safe-Way Door has added a new door to its lineup of high-density polyurethane insulated garage doors. Combining ruggedness and good looks with the benefit of an R-Value of 17.68, the new Ambient line is geared toward residential, commercial and industrial applications where superior insulating ability is desired. The high-density polyurethane core is credited with giving the Ambient line superior insulation properties, along with more strength for better performance and durability.



SCHWEISS DOORS

SCHWEISS DOORS

Booth 625 / Circle 211

Stop by the expo booth to see Schweiss' new heavy-duty hydraulic door wrap-around hinge design and ask about the new hydraulic "Build Your Own Door" kit. Schweiss is the leading worldwide door manufacturer known for its superior hydraulic door and bifold liftstrap door craftsmanship. Schweiss' custom-made engineered doors are specially designed for many applications, including commercial, industrial, agricultural, residential, hangars and dynamic designer doors. A Schweiss Door rep will demonstrate working models of both style doors at the Frame Building Expo.



SCOTT SYSTEMS

SCOTT SYSTEMS

BOOTH 245 / CIRCLE 212

Scott Systems develops and manufactures innovative, high-quality American-made storage and safety products for building and construction. Its unique products provide improved storage space and work platforms for the post-frame, renovation and general construction industries. Products include Float-Frame, Scaff-All and, specifically for the post-frame industry, the Post-Rack bracket system.

SEMMLER SYSTEMS INC.

Booth 213 / Circle 213

Big Red 111, Semmler's newest model for







Replaces Concrete Footings Of Equal Diameter

FootingPad® - Available in 10", 12", and 16"

Ditch the Concrete!

Is your below-grade footing ICC code-compliant?

ICC FootingPad® meets the ICC-ES building code acceptance criteria (AC49), Certified by ICC Evaluation Service (ESR-2147).

www.footingpad.com 800-522-2426

©2016 AG-CO, Inc., Patent No. 7827747, Made in USA



Weights 4 lbs.

VS.



Weights 90 lbs.

16" FootingPad®
Total Allowable Load: 4,167#
Based on 3,000 psf soil capacity

16" Concrete Pad

SEAL IT RIGHT, SEAL IT TIGHT!

35 Year Master Flash®

International Building Code® (IBC) • International Residential Code® (IRC)





10 SIZES
FITS ROUND PIPES
UP TO 28-1/2 INCHES



WATCH THE 5 STEP VIDEO

IF YOUR FLASHING DOESN'T HAVE A 35 YEAR WARRANTY, NEITHER DOES YOUR ROOF



Installation Video: <http://www.aztecwasher.com/installationvideos>



PH: (858) - 513-4350 FAX: (858) - 513-4305
www.aztecwasher.com • info@aztecwasher.com

Circle Reader Service #441



SEMMLER SYSTEMS INC

fabricating wood laminating columns features a design that contains 10,000 nails in one loading. Special design of in-line equipment best saves plant layout space and requires only one operator for the total system. Total system equipment includes the Big Red fabricator, conveyor system, gusset press, planer with chip collector, bunk-stacking cart with flanged wheels and track. Now available is the finger-joint system that features unique finger-joint detail. Available with jib crane with vacuum lift and scissor lift.

SFS INTEC

Booth 419 / Circle 214

SFS intec is a premier manufacturer of attachment



fasteners for metal building and post-frame markets. Fasteners include #9 woodGrips, #10 HiLo woodGrip with mill point and the #12 woodGrip XG with a large aggressive thread design for superior performance in OSB and plywood. Long-life fasteners include the everGrip bi-metal, woodZAC alloy cap and woodMAC SS capped fasteners. SFS intec is now a distributor for S-5! clamps, brackets and snow retention products. Other accessories include panel clips, ProfileVent ridge ventilation, pipe flashing and WG-7 foam closure.

SILVERCRAFT LLC

Booth 237 / Circle 215

Silvercraft is introducing pre-assembled



SILVERCRAFT LLC

aluminum Dutch doors, bale doors and sliding doors. Seamless, high-end doors are available in a wide array of styles and color combinations for any equine facility or hobby building. Silvercraft's product-design work is driven by contractors and end users who know what it takes from job site to timeless performance.



STOP BY OUR BOOTH AND FIND OUT WHY C.H.I. IS THE BUILDER'S PREFERENCE

BOOTH# **315**

chiod.com



Circle Reader Service #553

New Process Steel is the coated steel specialist shipping throughout the Midwest and South.

IF YOU NEED TRUCKLOAD QUANTITIES OF STEEL... WE CAN HELP!

Specializing in Post Frame Coils

- 29 gauge galvanized
- 26 and 29 gauge galvalume
- Combine colors for truckload quantities

See us at FBE Booth #238

NPS
NEW PROCESS STEEL.
www.nps.cc

Butler, IN	Ph: 888-280-8018	ccurtis@nps.cc
Alsip, IL	Ph: 800-972-6772	tpartipilo@nps.cc
Birmingham, AL	Ph: 800-742-6992	bleahy@nps.cc
Columbus, MS	Ph: 888-280-8018	ccurtis@nps.cc

Circle Reader Service #533

expo exhibitors

BY RURAL BUILDER STAFF

SILVERMINE STONE CO. -

Booth 603 / Circle 216

Silvermine Stone Co. manufactures Stack-N-Tack. Stack-N-Tack is a mortarless, waterproof, architectural stone-siding product that is installed by simply stacking it up and tacking it on. It can be nailed or screwed into any surface. Its patented design makes it easy to install, durable and maintenance free. By eliminating the mortar process involved in traditional stone applications, it dramatically cuts down on the cost, labor and expertise needed to install Silvermine stone.

SIMPSON STRONG-TIE

Booth 136 / Circle 217

Simpson Strong-Tie offers many fastening solutions. The Quik Drive auto-feed screw driving system and ProHX14 attachment can be used to speed up installation of washered screws while providing consistent results for pole barn metal roofing and siding. The Quik Drive ProPP150 system features an innovative Precision Placement nosepiece that allows for easy location of the holes in standing-seam metal roofing clips. In addition, the Strong-Drive SDWS and SDWH structural screws provide an easy-



to-install, high-strength alternative to through-bolting and traditional lag screws.

SNAP-Z

Booth 216 / Circle 144

The inventors of the Snap-Z Ridge Roof Vent System have designed this revolutionary ridge roof vent for standing seam metal roofs only. Patented vented closure systems are sold to dealers and distributors. The clean and neat appearance of the metal ridge roof vent will complement any roof.

ST FASTENING SYSTEMS

Booth 109 / Circle 218

ST Fastening Systems manufactures and supplies steel-frame and post-frame screws

for commercial, industrial, agricultural and residential metal roofing applications. Product strengths are drill quality and corrosion resistance, showcased on the Maxx SteelBinder and on the WoodBinder MB with micro-bit technology. This new point is the most consistent available today, and eliminates the slow-drill or no-drill complaint about sharp-point screws. All standard metal-to-wood screws have transitioned to this point, including the increasingly popular ZXL WoodBinder zinc-aluminum alloy head for 40-year-warranty roof systems. Solid and vented foam closures, pipe flashings, pancake- and wafer-head screws for standing seam roofs round out the product line.

STEEL DYNAMICS INC.

Booth 545 / Circle 219

Steel Dynamics Inc. (SDI) is a leader in the production of high quality, low cost, bare and pre-



DOORS DONE RIGHT. DOORS THAT WORK!

PHONE: 815-945-3667 • FAX: 815-945-7073 • WWW.IBEAMDOOR.COM
960 E. CEMETERY AVE. CHENOA, IL 61726

Heavy duty durability for contractor & consumer peace of mind



- Door kits are delivered to your desired location with all the hardware and frames pre-cut, pre-punched for ease of installation
- Doors are constructed of lightweight aluminum I-beams that are designed for openings up to 60' wide by 24' high
- Heavy duty military grade latches and high strength steel brackets and hardware are all included with door kits
- 15 year 110mph wind warranty; when you see it you will believe it; unlike any door out there
- Ultra Glide track is one piece of extruded aluminum with a 4,000 lbs. capacity and Ultra Glide trolleys have a weight capacity of 6,000 lbs.

Circle Reader Service #512



The Affordable Rollforming Equipment Manufacturer

Metal Rollforming Systems designs and manufactures reliable and affordable rollforming equipment and accessories, making us a leader in rollforming equipment manufacturing. Our unsurpassed technical support is unlike any other in the industry, we work until the job is done. Our customer's success is our success. For more information, please contact us at 1.888.284.6794 or visit us online.

-Single & Double Deck Rollformers
-Trim Rollformers

-*NEW* Patriot Rollforming Line
-Coil Reels

-Precision Cut Slitting Lines

-Sheet Stackers

-Coil Upenders

-Ridge-Cap Press



1.888.284.6794 www.mrsrollform.com

Circle Reader Service #584

painted steel for the metal construction industry. Its wide-width, light-gauge, pre-painted flat-rolled steel is perfectly suited for roof, wall and fascia systems used in the construction of metal structures. Also, SDI's pre-paint lines run parallel to its galvanized and Galvalume lines, reducing transportation costs and shortening the supply cycle, saving time and money.

STILETTO TOOLS

Booth 336 / Circle 220

Stiletto's Titanium Ti-Bone hammer has become the tool of choice for professional post-beam and pole-barn framers in the U.S. and Canada because the 20-, 30- and 60-penny spikes these builders use are hammer and elbow killers. Titanium offers 10 times more dampening of recoil shock than steel hammers and has an indefinite service life with its replaceable steel faces.



SWENSON SHEAR

SWENSON SHEAR

Booth 137 / Circle 221

Swenson Shear has spent the last year revamping all product lines in order to continue to provide the highest quality metal panel preparation for concealed- and exposed-fastener panels, soffit and siding and stone-coated steel. The SnapTable HD adjusts to accommodate between 12- and 22-inch panels, and is equipped to notch, slit and hem up to 33-inch offsets for hips and valleys. The SnaptablePRO is the newest addition to the line added to provide the capability to slit and hem up to 60 inches for any commercial, industrial or residential job site.



SYMUN SYSTEMS INC. / CONSTRUCTION MAESTRO

SYMUN SYSTEMS INC./ CONSTRUCTION MAESTRO

Booth 106 / Circle 222

Construction Maestro from Symun Systems is known for its detail, accuracy and ease of use. It automates the process of generating all necessary field-ready plans and material lists within just a few minutes for a post-frame or stud-frame building.

TAYLOR STEEL INC.

Booth 134 / Circle 223

Since 1967, Taylor Steel has been processing

and selling high-quality, value-added flat-rolled steel to customers throughout North America. Privately owned and operated, it has more than 1,250,000 square feet of plant space in five Canadian facilities and more than 256,000 square feet in its Ohio facility. Housed within 1,500,000 square feet of floor space are 18 processing lines that produce an annual capacity in excess of

two million tons. Today, the company carries a complete range of products including hot-rolled, cold-rolled and coated steel in a wide range of gauges, widths and grades. Stocked are products between .008 and .500 thick and up to 72-inches wide. It also supplies the metal building and component markets with acrylic and pre-painted galvanized and Galvalume. Taylor Steel has the

WE'VE BEEN PART OF THE
AMERICAN RURAL LANDSCAPE
FOR OVER HALF A CENTURY



— THE ONLY COIL COATER THAT COMES CLOSE —



Precoat Metals

SUCCESS. **YOURS** IS OURS.

www.PrecoatMetals.com 314.436.7010

ARMOREL BALTIMORE BIRMINGHAM COLUMBIA GRANITE CITY (2) GREENFIELD
HAWESVILLE HOUSTON JACKSON KINGSBURY PORTAGE ST. LOUIS WEIRTON



Circle Reader Service #399

expo exhibitors

BY RURAL BUILDER STAFF

ability to apply customer colors, or customers can choose from its standard color chart.

THERMAL BUILDING CONCEPTS

Booth 326 / Circle 224

Thermal 3Ht's unique combination of components creates a high-performance insulation. It can be used with all types of construction: agricultural, commercial, residential, basement walls and under concrete. To properly insulate any building structure, you must use an insulation that controls all three forms of heat transfer and can perform in any climate zone. Thermal Building Concepts provides education, training and 'real world results.'

TIMBER TECH ENGINEERING INC.

Booth 108 / Circle 225

Timber Tech Engineering provides structural design of building components and complete building systems for post-frame and light-wood constructed buildings. Timber Tech also offers structural design of foundation systems, roof systems, concrete, masonry and steel design. Engineer certifications are available for all 50 states and Canada. Designs are customized for

each specific application. Timber Tech would enjoy the opportunity to review its services with you as well as show you some of its recently-completed projects.

TIMBER TECHNOLOGIES

Booth 725 / Circle 226

Timber Technologies is a full-line glulam manufacturer of Titan Timber columns and beams for post-frame buildings. Titan Timbers are straight, strong, reliable, easy to cut, screw and notch because of the glue-laminating and finger-jointing process. Multiple plys and lengths are engineered or designed to your specifications with higher design values than solid or nailed columns. Titan Timber columns are .60CCA treated for ground contact and every column is usable on the jobsite. AITC 3rd party-inspected means Titan Timber meets code approval nationwide.

TRIANGLE FASTENER CORP.

Booth 314 / Circle 227

Triangle Fastener Corporation is a leading supplier of standard and specialty fasteners, tools, sealants and accessories for the commercial construction

industry. A complete line of fasteners for metal-to-metal, metal-to-wood, drywall and concrete anchoring is available from each of its 23 locations. Triangle's Need-It-Now! Program is designed to provide fastening solutions for difficult applications.

TFC has eight in-house painting facilities that can custom-color-match fasteners to exact requirements with delivery in three days or less. TFC offers job-site assistance, technical assistance, inventory-management programs and product development. The TFC Market-Specific Catalogs can be found on the company's website and are complete with products and technical information on a wide variety of fastening systems solutions.

TRI-STATE LUMBER COMPANY

Booth 224 / Circle 228

Tri-State manufactures southern yellow timbers at its Fulton, Mississippi, sawmill (from 4x4s to 10x10s). It



Royal Crowne Cupolas

ROYAL CROWNE OUTDOOR ACCENTS

717-355-2254

120MPH WIND!

- * 120 mph Wind Rated
- * Easy installation
- * Sizes 24" - 72"
- * Square or Octagon
- * Louvers or Windows
- * Weathervanes

www.royalcrownecupolas.com

#706 FRAME BUILDING EXPO 2017

Circle Reader Service #426

SCHWEISS THE DOOR LEADER

DOORS

HYDRAULIC - OR - BIFOLD

ONE-PIECE DOORS STRAP LIFT DOORS

#625 FRAME BUILDING EXPO 2017

SCHWEISSDOORS.COM

Circle Reader Service #414

has dry kilns and planer as well as re-saw and re-man capabilities. Tri-State Lumber can also center-match 2-x's and has a treating plant that treats CCA as well as dispersed copper azole. It can also do larger timbers and specialty timbers on a by-order basis.

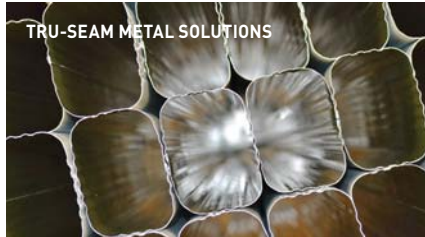

TRU-SEAM METAL SOLUTIONS
Booth 729 / Circle 229

Tru-Seam Metal Solutions is a premium manufacturer of gutter and downspouts that match your metal roofing and siding exactly. Tru-Seam offers gutter solutions in K-style and half round (5-, 6-, 7-inch K-S and 6-inch H.R.) with rectangular downspouts and elbows (2-inch x 3-inch and 3-inch x 4-inch) in aluminum and steel (Perfect Match).



TRUSSMATE
Booth 444 / Circle 230

Trussmate is the easy, fast and economical way to set trusses. It installs where you would normally use a temporary tie. It is economical because it is reusable and cuts down on labor costs. It is simple because it installs on the ground with a 1-tack nail (not in the air while standing on webbing). It is safe because no men or equipment are needed in the webbing during initial installation of trusses. It is strong because it is made from solid aircraft aluminum. And it is accurate because it is notched for centerline measurement. Visit the Expo to take a closer look at this revolutionary product.

UNITED STEEL SUPPLY
Booth 536 / Circle 231

United Steel Supply is a leading distributor of Galvalume, galvanized and pre-painted steel coils for metal roof and siding applications in the agricultural, commercial, industrial and residential markets. The company's products are made of the highest quality steel, allowing customers to maximize production efficiency and provide top quality material and efficient yield to final users. Visit the Expo to get a quote, make a purchase or hear what United can do for you.

U.S. STEEL TRUSS
Booth 123 / Circle 232

Established in 1984, U.S. Steel Truss is a manufacturer and distributor of steel building components. Steel trusses for standard or custom-building packages are available. U.S. Steel ships nationwide and designs its trusses to meet local building codes across the U.S. for any snow or wind load. Truss sizes range from 12-80-foot wide clear spans with 8-28 foot high sidewalls.

VALLEY LUMBER CO. INC.
Booth 243 / Circle 233

Located in the beautiful Tennessee Valley, Valley

BIG RED III

Make Your Own Nail-Lam Column





SEE THE ACTION

Total Fabricating System - www.semmlerinc.com

- Contains 10,000 nails in one load
- Total inline fabricating equipment; planner, conveyor, stacking cart
- Finger joint equipment options
- Requires only one fabricator
- Column engineering and design
- Fabricates 3 ply, 4 ply, 2x6 and 2x8 columns



SEMMLER SYSTEMS INC

Ph: 605-787-4765 • Email: jimsemmler1@msn.com

Circle Reader Service #454

IN THE MARKET FOR SNOW RETENTION?
WE'VE GOT YOU COVERED





POLYCARBONATES



MEC DECK MOUNT



iCLAD



Raising the Bar in Snow Retention

888-SNO-GEMS
SNOGEM.COM

Circle Reader Service #482



+ANOTHER VIEW



A Gardeners' Planting Paradise

Black Creek Greenhouse Inc. is a popular destination for gardeners in the Lancaster County area of Pennsylvania. It has been locally owned and family operated since 1980. This post-frame retail store was built to handle expanding inventory and eager crowds. Because the area can get heavy snows, snow guards were deemed a must on the standing seam metal roof to help protect people, plants and products from dangerous slide-offs. Levi's Building Components provided these photos of the store, which features Levi's 6500 Snow Defender Snow Guards. **RB**

THE DETAILS:

PROJECT: GREENHOUSE RETAIL STORE

- Building size: 160 x 48 feet
- Building location: Southeastern Lancaster County, Pennsylvania
- Architect: Harvey Zimmerman
- Contractor: Ralph Brubaker
- Roofing: ABSeam standing seam in dark bronze from A.B. Martin Roofing & Supply, installed by Integrity
- Fasteners: Levi's Pancake Screws
- Snow Guards: Levi's 6500 Snow Defenders





FINDING THE RIGHT NICHE

Door and window company finds success filling special-market needs



[Editor's Note: Rural Builder is rolling out a new feature column called "How Things Are Made," offering a closer look at some of the manufacturing companies that provide products to rural builders.]

Walmart founder Sam Walton once said: "If everybody is doing it one way, there's a good chance you can find your niche by going exactly in the opposite direction."

That same philosophy is serving A.J. Manufacturing quite well. The company has found several niches in the very competitive world of door and window manufacturing.

The company makes its home in the small rural town of Bloomer, Wisconsin. The town's nicely groomed homes and businesses are signs of prosperity derived from successful manufacturing companies and numerous sand mining and related business located throughout the surrounding area. AJ, however, is the major employer in town, making its headquarters in a large, historic brick building, with manufacturing operations in three facilities located within minutes of each other.

President Todd Carlson and Inside Sales Manager Vicki Wachtendonk explained during a site tour that a little more than 50 percent of the company's business serves the post-frame industry, itself a niche. The remainder is an interesting blend of smaller niches: HVAC access doors, air-handling cabinets, modular data center doors, revolving, airlock and emergency exit doors for air supported structures (domes), and even doors for a special ventilation system for hog confinement and poultry houses. Some niches are so specialized they cater to specific customers on contract.

The company started in the 1960s with insulated doors. For years, the mainstay was residential storm doors. "But that's the changing model where, if it's simple—all the same sizes, no value added—you can get it from China. We need more challenge than that, so short lead-time and high

COMPANY:

A.J. Manufacturing

WEBSITE:

ajdoor.com

EMAIL:

info@ajdoor.com

PHONE:

800-328-9448

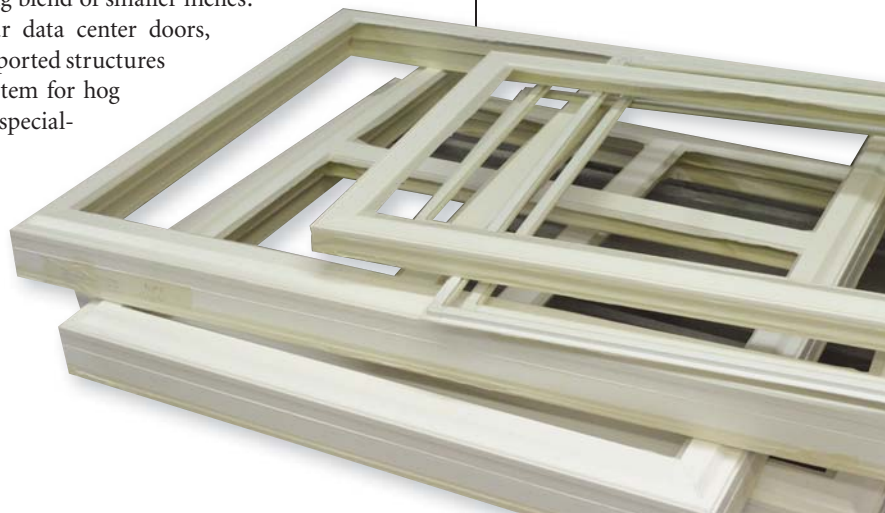

product performance and excellent customer service is where we live now,” Carlson said.

Computerized machines and systems that can quickly adapt and measure to a finite degree have replaced old tooling methods that are less precise and time consuming. This has given them liberating flexibility.

“We don’t batch things by size,” Carlson continued. “We don’t say, we’re only going to make [this size] today and [that size] tomorrow. It’s one piece at a time, or “one piece flow.” All of our processes are able to flex by attribute. Here you have a door without a window in it, here you have a door with a window in it, and they both flow together to fill the order.”

A case in point is one regular customer that has 1,750 unique sizes that generate the potential for over 75,000 unique doors. “We build these one at a time, in less than 10 days and 100 percent on-time.” Carlson said. “Sometimes we’ll go all year and not build some of them and there might be duplicates and multiples of others, but when they add a window or change the position of where the hardware goes, it becomes another unique door.”

What all the company’s products have in common is the way AJ manufactures them. Whether fiberglass, steel, aluminum or vinyl, all doors and windows start as thin skins and any holes for glass or hardware are cut out first. Only then are the skins formed into hollow boxes and the boxes injected with high-density foam that dries quickly into a rigid impenetrable mass to give the box its structure. This differs from other manufacturers that create the boxes first and then cut the holes.

“Our way, it’s leak resistant, because the foam encapsulates the window frame, and we don’t throw the foam in the landfill,” Carlson said.

And not just any foam will do.

“Foam injection is a fairly scientific process,” Carlson said. “Every day the chemistry, the temperature, ratio, and weight is tested and confirmed it is just right. Imagine our foam is like Nike tennis shoes: you can get canvas, vinyl, leather and then Air Jordans. This is like the Air Jordans, as the chemistry is more refined because we use it for structure. That puts it in a whole new category.

“Two years ago we went through over a year-long process to change our chemistry,” Carlson continued. “We have no ozone-depleting chemistry in our foam. We did it for a couple reasons. First it’s the right thing to do, and two, it’s emerging as a cost-stable alternative because there’s more regulatory pressure on the old chemistries. It was a tough, long, hard process to get done, but for us it’s the glue that holds everything together.”

A.J. Manufacturing has a team of engineers tasked with coming up with new ideas and improving old ones. Post frame offers them challenges to keep finding niches. When the company saw the demand for vinyl heating up, they tested the waters by partnering with an established vinyl window company. But then they went a step further by developing a way to make vinyl a leak-free alternative for corrugated siding. Their answer was the EZ-V trim for windows.

“EZ-V was an effort to appropriately translate

residential vinyl windows to corrugated steel siding,” Carlson said. “That was the missing piece. Everyone could buy vinyl but you couldn’t get it to a leak-free installation for corrugated siding.”

Carlson said the common use of J-channel found in off-the-shelf windows, made primarily for the residential market, presents special problems for buildings with metal. “You run into challenges sealing the bottom corners and proper flashing,” Carlson said.

The EZ-V system uses a trim cap and a seal against the vertical to eliminate exposed points where moisture can infiltrate. Fasteners are concealed behind the trim.

“We have three patents on the EZ-V. For us it was about two years in development. The idea is, here is a trim system that will attach universally to vinyl windows and provide a transition from residential to residential post frame.”

When it was obvious that vinyl was becoming more popular than aluminum, AJ bought a regional manufacturer of a high quality vinyl window system and readapted the manufacturing process to fit the AJ model. “That’s the Harmony Line,” Vicki Wachtendonk said. “We moved all the equipment here and the employees...”

Today the demand for vinyl windows for all markets is explosive, rising on a nearly vertical trajectory. “Vinyl have been in the industry for 10-15 years but no one until now has stepped up to finally do it [for the post-frame industry], we’re the only one that manufactures vinyl windows [for post frame],” said Carlson.

Still, AJ continues to make aluminum windows.



While highly mechanized, AJ also relies on the personal touch of employees.





AJ employees are preparing products for safe transport.

“Aluminum is easy to manufacture because it’s very stable in terms of dimensions, durability and durable paint finishes. Tooling for aluminum is pretty easy to do. Aluminum meets commercial guidelines. That’s something vinyl doesn’t necessarily have,” said Wachtendonk.

A recent addition at AJ is the Main Street window line. Main Street is a high-quality window that is designed to be price competitive with major manufacturers. With AJ also supplying doors, it can ship doors and windows together, eliminating additional suppliers and the related hassles.

AJ’s door line for post frame offers a good-better-best lineup of aluminum and steel jamb doors in their Partner, Responder, SST Stainless steel, and the traditional roll-form door series (3100, 5100 and 7100).

Wachtendonk believes there is a good reason why builders need to pay attention to the quality of doors they use in any project. “When that building owner takes ownership of that building, what do they walk up to and put their hand on first?” she quizzed: “It’s the door.”

“And if it squeaks or binds, it reflects on the whole building,” Carlson added. “There’s a lot on the line.

Wachtendonk follows through with that thought: “We know there are many door options available to the builder and customer...is the lowest-cost door where you want to save?

“Quality, warranty and durability are worth looking for and paying for,” she said. “It’s good for the builder because there are fewer issues, and it’s good for the customer because they are reassured of their purchase every time it works and works well.”

Like its windows, AJ doors are not mass-produced, but rather built as an order dictates. Wachtendonk said: “The lead time to get a white, 3068 basic door is no different than to get a bronze door with a window and a deadbolt because that’s how we’ve evolved. That’s what we do.”

Like its windows, Wachtendonk noted that at AJ: “To get a specialized product is not that special.” **RB**



AJ doors are not mass-produced, but rather built in a “one-piece flow.”

How to handle vinyl windows properly

Vinyl windows continue to grow in popularity for buyers of noncommercial structures. They are less expensive than aluminum, yet have great thermal and energy-saving properties and they can be made in many profiles such as wood grains. But there are proper ways of handling vinyl that are very different than those for aluminum. Todd Carlson and Vicki Wachtendonk offer these tips for builders:

AVOID SUN EXPOSURE WHEN STORING

Vinyl windows shrink-wrapped for delivery should not be stored in direct sun, if at all possible. Although installed they perform well in all weather conditions, shrink-wrap creates a greenhouse effect, possibly resulting in warping. Place the windows under cover, or cut the shrink-wrap to allow the heat to escape if storing even for a day or two.

HANDLE WITH EXTRA CARE

Because vinyl is not as rigid as aluminum, don’t pick vinyl windows up one-handed. Make installation a two-man job. It may seem like a waste of labor, but vinyl installation will typically take less time overall, while also avoiding the risk of compromising the vinyl’s integrity.

DON’T STACK VINYL

Vinyl is not as rigid as aluminum so “don’t stack like cordwood”. Store on end and when transporting, avoid strapping that can damage and warp the product. Look for packaging that provides a place for straps and protects the window.

DON’T TREAT VINYL WINDOWS AS STRUCTURAL MEMBERS

They are not structural members, so they need to be handled as a component. Once they are installed, then they rely on the structure for rigidity.

The most **comprehensive** guide for building with post frame



- Eight brand-new chapters
- More than 200 pages
- Hundreds of photos, diagrams, and design tables



Visit www.nfba.org to order your copy now.

Moisture problems and solutions

Because addressing present or potential moisture problems in a building is so critical, *Rural Builder* has teamed up with Joseph M. Zulovich, Ph.D., P.E., in a series of five articles that looks at the primary causes and cures of moisture problems and solutions. Part 5 continues the topic of how to protect the exterior building envelope, with this final segment looking at ventilation.

Removing excess moisture with ventilation [Part 5]



As introduced in Part 4 of this 5-part series, removing any accumulated moisture is an important step in addressing potential moisture problems. Proper ventilation—removing inside air and replacing it with outside air—will safely remove excess moisture from inside the building system. But while air infiltration will ventilate a building, the exterior building envelope may be compromised by air escaping into that area (refer to Part 4 of this series for further details).

A ventilation system needs to be operated to remove indoor moisture when moisture is present on the inside of windows or exterior doorframes (see photo at right) during winter (this article focuses on ventilation needs of heated facilities during cold weather). Exterior building components like windows and door frames often have lower R-values compared to exterior insulated wall sections. During winter weather, a building component with a lower R-value will usually have a lower inside surface temperature compared to inside surface temperature on components with higher R-values. This difference in R-values

is why condensation will form on windows and door frames before it forms on insulated wall areas.

When the surface temperature of the building component is lower than the dew point temperature of the air inside the building, condensation will form on the inside surface of the component. Psychrometrics provides an understanding of the relationship of air-moisture mixtures and dew point temperature. Basic psychrometrics can be studied using a simplified psychrometric chart shown in **Figure 1**.

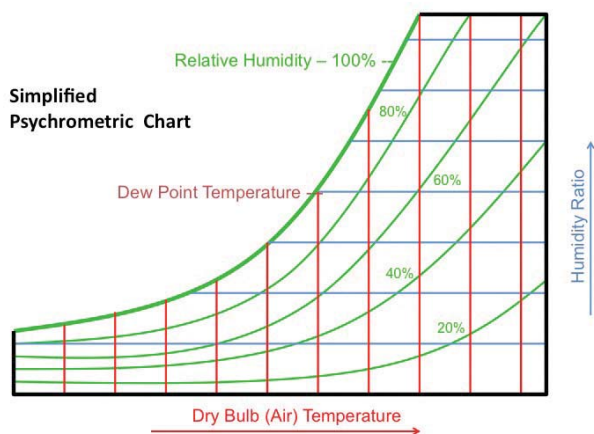

Figure 1. The Difference Between Room Air Temperature and the Dew Point as a Function of RH. This example is taken from "Moisture Control Guidance for Building Design, Construction and Maintenance" found at <https://www.epa.gov/sites/production/files/2014-08/documents/moisture-control.pdf>.

THE SCIENCE OF PSYCHROMETRICS

Air temperature (red lines) increases from left to right, and the amount of moisture that air can hold increases as air temperature increases.

The *relative humidity* (green lines) indicates how full the air is of moisture at a given air (dry bulb) temperature.

The *humidity ratio* (blue lines) increases from bottom to top and indicates the actual amount of moisture in the air.

The *dew point temperature* (purple letters) is found where the humidity ratio line intersects with the 100 percent relative humidity line, with the dew point temperature being the air temperature at the intersection. Dew point temperature is the air-moisture mixture property that indicates when condensation will occur. A surface that is cooler than the dew point temperature of the air in contact with the surface will have condensation form on the surface. Conversely, if a surface is warmer, the surface will remain dry (no condensation).

The *air state point* is located where the air temperature line intersects with the relative humidity line. A humidity ratio line that intersect with the air state point is followed horizon-

160 DOORS & WINDOWS

SCHWEISS THE DOOR LEADER

DOORS

Booth #625

HYDRAULIC - OR - BIFOLD
ONE-PIECE DOORS STRAP LIFT DOORS

507-426-8273

• AVIATION • SHOP DOORS

SCHWEISSDOORS.COM 507-426-8273

250 MISCELLANEOUS

Wall and Ceiling Panels and FORMS

BOOTH 209
NFBA Show

HOLY COW! These panels are bright!

- Sanitary - Smooth
- Non-Porous
- Easy to Clean
- Perfect for Non-Food Contact Surfaces
- For Corrosive or High-Moisture Areas
- Made in the USA

888-818-0118

www.epiplastics.com
email: info@epiplastics.com

EXTRUTECH PLASTICS, INC.

NEWS & SPECIAL FEATURES

www.RuralBuilder.com

250 MISCELLANEOUS

Old Country Cupolas

THE FINISHING TOUCH

We are based in western Montana, which enables us to better serve the western states. We offer high-quality cupolas, shutters and gable end vents for all your building needs. We can make an exact match to most metal company colors. We offer 16"-72" square cupolas and 24"-48" Octagon cupolas. All are available louvered, vented or with windows and a light kit. They come fully assembled for ease of installation. Give us a call or send us an e-mail for more information.

Seth Denlinger
Old Country Cupolas, 60281 Hillside Rd, St. Ignatus, MT 59865
406-552-3933 | Old.country@privategarden.org

400 ROLL FORMERS

Booth #519

BRADBURY
THE BRADBURY CO., INC.

We Build Machines... We Sell Solutions

Panel Lines	Ridge Cap Benders
Standing Seam Lines	Insulated Panel Lines
Control Retrofits	Portable Roll Formers
Trim Roll Formers	Hemming Roll Formers
Hydraulic Folders	Slit & Recoil Lines
Garage Door Lines	Purlin Lines

620.345.6394 www.bradburygroup.com

600 TOOLS/EQUIPMENT DISTRIBUTOR

MARION MANUFACTURING

- Automation Systems
- Metal Construction Rollformers
- Coil Processing
- Forming & Fabrication
- Recondition Existing Machines

Booth #733

WE ADD THE VALUE TO METAL

1-888-865-8740 www.marionmanufacturing.com

Clark Industries, Inc.
Since 1967 - Monett, Missouri

Considering equipment?
Consider Clark.

- Roof & Floor Truss Presses
- Multi-Head Truss Presses
- Modular Truss Presses
- Shuttle Presses
- Jack Presses
- H.D. Chord Splicers
- Post & Column Machines
- Floor Truss Machines
- Electric Horizontal Stackers
- Electric Peak-up Stackers
- Conveyor Systems
- Custom Machinery

Call us toll free at: 800.743.9727
or visit us on the web at: www.clark-ind.com

LAM-PLY TRUSS

The Truss That Will Carry The Load

- Spans up to 72 ft.
- Spacings up to 12 ft. on center, depending on the load you desire
- Bird Nesting Control
- Better Ventilation & Visibility
- No Feed Alley Post Obstruction
- Additional Ceiling Height

Starwood Rafter Uses

- Pole Sheds
- Free Stalls
- Pavilion Shelters
- Machinery Storage
- Riding Arenas
- Solar Barns

Starwood Rafters, Inc.
W24141 Starwood Lane
Independence, WI 54747
(715) 985-3117 • 888-525-5878
www.starwoodrafters.com

Circle Reader Service #375

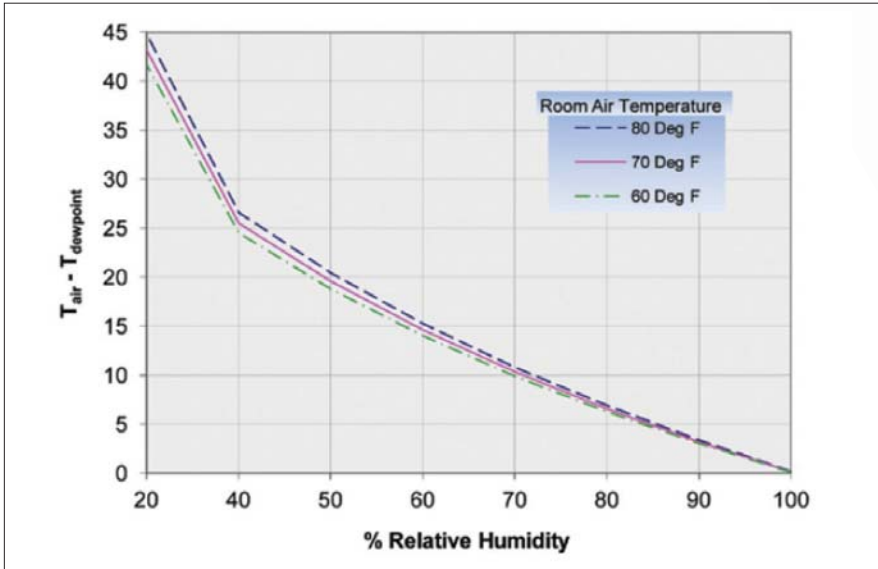

Figure 2. Source: <https://www.epa.gov/sites/production/files/2014-08/documents/moisture-control.pdf>.

tally to the line to the 100 percent relative humidity line to determine the dew point temperature at the air temperature and relative humidity used to find the air state point.

When the relative humidity is less than 100 percent, the air temperature will be higher than the dew point temperature. The difference between air temperature and dew point temperature as a function of relative humidity is shown in Figure 2.

THE BOTTOM LINE

To minimize condensation on inside surfaces of exterior building components, one wants to operate a building such that the inside dew point temperature is lower than the inside surface temperature of any exterior building com-

ponent. The inside air temperature will be similar or somewhat higher than the inside surface temperature of all exterior building components. A large difference between air temperature and dew point temperature exists by maintaining a low indoor relative humidity (Figure 2).

The required difference between dew point temperature and inside air temperature depends on the weather conditions and R-value of the building component. The climate zone map, as introduced in Part 4 of this series, provides some insight into the required minimum R-value of a window or doorframe. Colder zones should have higher window and door minimum R-values. A higher R-value will result in a higher inside surface temperature. This allows indoor air to have a higher dew point temperature before condensation begins to form.

Once a building is constructed, not much can be done about increasing the R-value of a component. If condensation is forming on the inside surface for an unacceptable amount of time, then one must use ventilation to remove moisture from inside the

Figure 3. Source: <https://www.epa.gov/sites/production/files/2014-08/documents/moisture-control.pdf>.

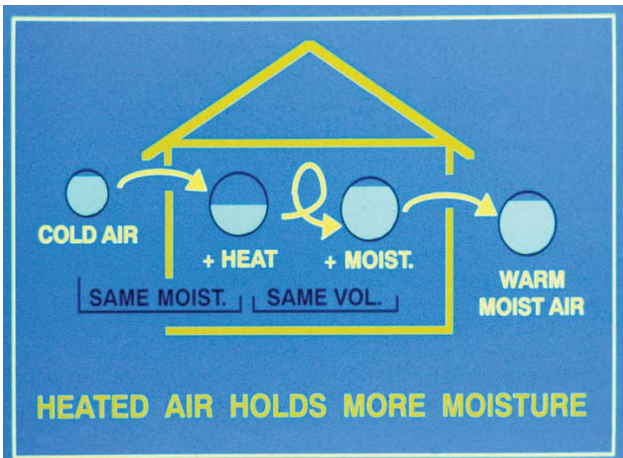

building. A properly operating ventilation system will decrease the inside dew point temperature as moisture is removed. The amount of ventilation needs to be high enough so that condensation no longer forms in the inside surfaces.

The reason a ventilation system can remove moisture from inside a building can be graphically seen in Figure 3. When air is heated (increasing the air temperature), it can hold more moisture. The heated dry air from outside can absorb indoor moisture and will remove moisture from the building when the air is exhausted out of the building.

Building ventilation is done to:

- Remove excess moisture
 - And must be continuous when a continuous moisture generation source is present
 - Or can be intermittent to control periodic indoor moisture problems
- Improve and maintain indoor air quality

The amount of ventilation needed depends upon several of the following factors:

- Moisture generation rate
- Moisture generation duration – continuous or intermittent
- Air temperature rise from outside to inside

A properly-sized ventilation system has just enough capacity to remove the excess moisture generated inside the building while maintaining adequate indoor air quality. Keeping the ventilation capacity correct will minimize the amount of supplemental heating required to maintain the inside temperature during winter.

All ventilation systems have the following five functional components:

1. Inlet – location(s) for air to enter the building space
2. Outlet – location(s) for air to leave the building space
3. Driving Force – reason air moves through the building space (the force that moves the air)
4. Distribution – how and where air moves through the building space
5. Path – how and where air moves through the building system

35,000 products in-stock when you need it...

YESTERDAY!

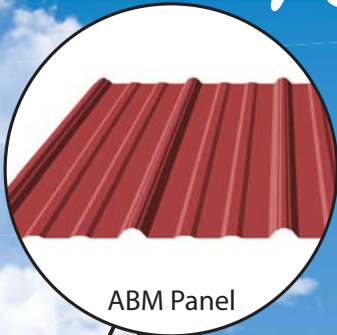

ABM Panel



Ridge Cap



Ultra Vent
(20' Rolls)

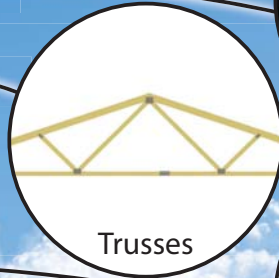

Trusses



Lumber



Windows



40-year
Screws



GluLam
Posts



Stock
Trims



82 Garden Spot Road
Ephrata, PA 17522

717-445-6885

35 Ridge Road
Newville, PA 17241

717-776-5951

Online Catalog: abmartin.net/catalog



A. B. MARTIN
ROOFING SUPPLY, LLC

Roofing & Siding • Hardware • Lumber

Circle Reader Service #291



Welcome To The Next Generation Of Durability



Tried and tested in the harshest environments.

Everlast Roofing, Inc. is proud to introduce you to Colorbond®, a proprietary paint system which provides superior protection and resistance against weather and UV exposure. Developed by Bluescope Steel through extensive research and real-world application, Colorbond surpasses all other pre-painted steel in both field-testing and real world applications for over 50 years. Exclusively available through Everlast Roofing in the U.S.A., Colorbond® comes in 17 long-lasting colors. The addition of Colorbond®'s proven paint system to Everlast's well-known durable and innovative metal roofing and siding, Everlast Roofing can confidently say that "Our Name Says It All".

Colorbond®
COLORBOND® is a registered trade mark
of BlueScope Steel Limited.

Learn More About Our Innovative New Process Now
everlastroofing.com • 888.339.0059

Circle Reader Service #407

